

# Chinon CA-4 / 4s

This camera manual library is for reference and historical purposes, all rights reserved.

This page is copyright© by mike@butkus.org M. Butkus, NJ.

This page may not be sold or distributed without the expressed permission of the producer

I have no connection with Chinon Co., Japan

On-line camera manual library

[Back to main on-line manual page](#)

If you find this manual useful, how about a donation of \$3 to: M. Butkus, 29 Lake Ave., High Bridge, NJ 08829-1701 and send your e-mail address so I can thank you. Most other places would charge you \$7.50 for a electronic copy or \$18.00 for a hard to read Xerox copy.

**This will allow me to continue to buy new manuals and pay their shipping costs. It'll make you feel better, won't it?**

If you use Pay Pal, use the link below. Use the above address for a check, M.O. or cash.

Venmo is @mike-butkus-camera

[www.PayPal.me/butkus](http://www.PayPal.me/butkus)



**The only difference I can find between the two models is the CA-4 has an electronic self-timer against the manual one on the CA-4s.**

1. Shoulder strap eyelet
2. Frame counter
3. Shutter release button/Exposure meter switch
4. Film advance lever



5. Shutter operation mode selector
6. Hot shoe
7. Film speed dial/Exposure compensation dial
8. Film rewind knob/Back cover opener
9. Self-timer lever
10. Lens lock release lever

- 11. Aperture ring
- 12. Depth of field scale
- 13. Focusing ring
- 14. Film chamber
- 15. Viewfinder eyepiece

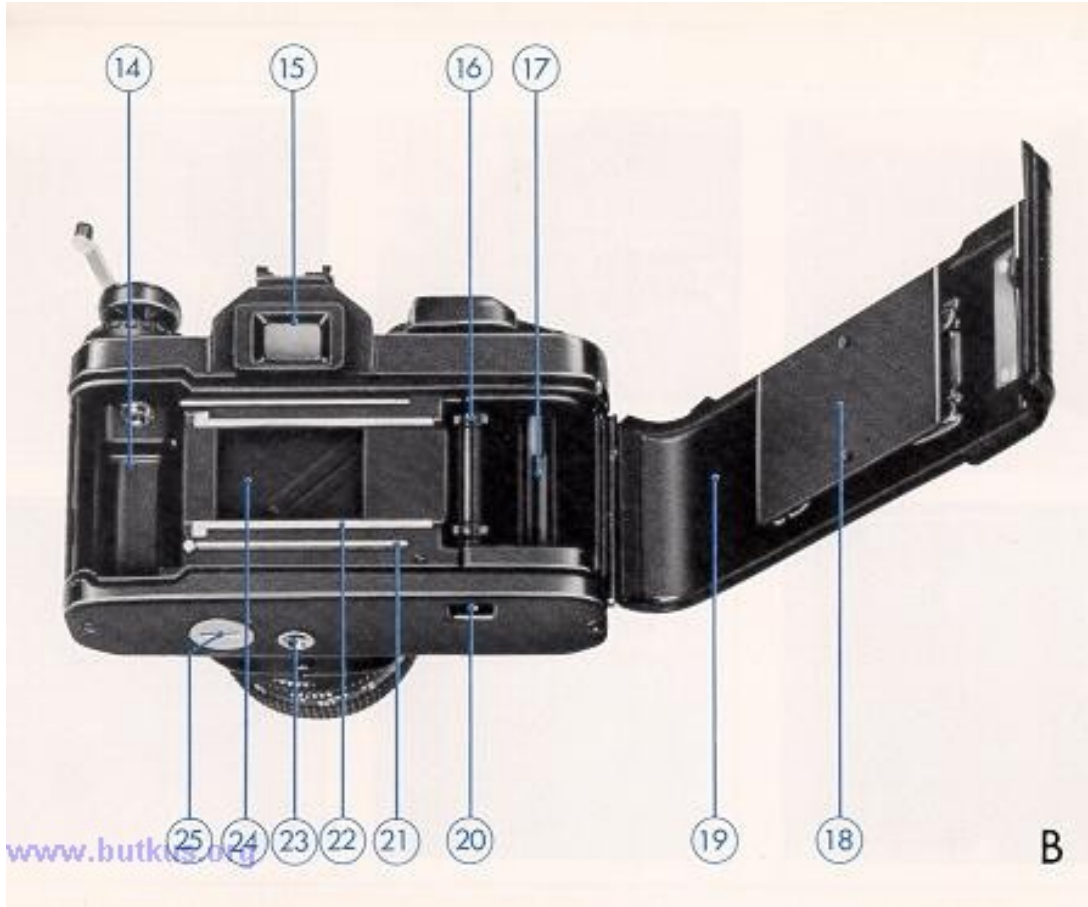

- 16. Sprocket teeth
- 17. Take-up spool
- 18. Film pressure plate
- 19. Film chamber cover
- 20. Rewind button
- 21. Film guide rail

22. Film rail

[www.orphancameras.com](http://www.orphancameras.com)

23. Tripod socket

24. Shutter

25. Battery compartment cover

## **SPECIFICATIONS**

**Type:** 35mm automatic SLR (Single Lent Reflex) compact camera with aperture priority exposure system (AE).

**Picture Format:** 24 x 36mm.

**Lens Mount:** Chinon Universal bayonet mount.

**Mirror:** Large, quick return, shockless system.

**Shutter:** Seiko MFC electromagnetic metal focal plane shutter, stepless speeds from 1 to 1/1000 sec. on automatic,

"B", "X" (X = 1/100 sec.), Automatic speeds electronically controlled.

**Viewfinder:** Fixed eye-level pentaprism, central split image with microprism collar and ground glass, 10 LED's indicate shutter speeds and over/under exposure.

**Viewfinder Magnification:** 0.87x

**Viewfinder Visibility:** 92%

**Exposure Meter:** TTL, center weighted full aperture system employing a silicon blue photo cell.

**Exposure Compensation:** Built-in +/- 1 EV in one third stop increments.

**Exposure Range:** EV+2 (F/1.9, [sec.]) to EV +18 (F/16, 1/1000 sec..) - ASA 100 F/1.9 lens.

**ASA Range:** 25 - 3200 (DIN 15 - 36) with safety lock.

**Film Advance:** Single stroke in an arc of 130° with 25° stand off.

**Film Counter:** Automatically indicates number of exposures and resets to " S " when camera back is opened.

**Film Rewind:** Folding crank type.

**Accessory Shoe:** Hot shoe type with X sync. and contact for Chinon dedicated flash.

**Synchronization:** "X" strobe sync. at 1/100 sec.

**Self-Timer:** Built-in

**Popover Source:** Three 1.5V silver oxide G13 batteries (S-76 type).

**Battery Test:** Built-in with LED indicator. Meter ON/OFF Switch: Meter switch is activated when shutter release button is pressed, meter remains on for several seconds after button is released.

**Camera Back:** Hinged, swing open type, detachable, memo holder provided.

**Body Dimensions:** 135.5 (W) x 86.0 (H) x 50.5 (D) mm. (5.33/t x 3.38" x 1.99")

**Body Weight:** 455 grams (16.0 oz.).

## INTRODUCTION

Welcome to the world of CHINON photography!

Your Chinon CA-4 /4s camera is one of the most advanced 35mm SLR cameras incorporating features normally found only in higher priced models.

This fantastic compact camera employs the latest state-of-the-art electronics which will ensure carefree operation every time.

In order to take full advantage of the features of your CA-4/ 4s, please read the instruction manual carefully so as to totally familiarize yourself with the camera before actually starting to take pictures.

We thank you for choosing CHINON quality products and we wish you years of satisfactions and enjoyment.

## BASIC OPERATION - CA-4 / 4s

### INSTALLING THE BATTERIES

1. By using a coin, unlock the battery compartment cover by turning it counterclockwise (Fig. 1).
2. Remove the battery holder which is attached with the cover. Then, place three 1.5V G-13 type silver oxide batteries (Eveready S-76 or equivalent) with the plus (+) side facing upwards (Fig. 2)...
3. Replace the battery compartment cover by turning fully clockwise (Fig. 3).



Note: Clean the batteries with a dry cloth or tissue paper before inserting and thereafter every six months.

- Make sure that the batteries are inserted correctly, i.e., check polarity.
- The shutter speed indicator LED and the action lamp will operate only when batteries are correctly installed and fresh.

## BATTERY TESTING

To test the batteries, set the shutter operation mode selector to the "AUTO " position (Fig. 4). While looking at the shutter speed indicator scale in the viewfinder, slightly depress the shutter release button. If the batteries are in good condition (battery voltage is high enough), at least one of the indicator LEDs will light up. If an LED fails to illuminate, the batteries are too weak and need to be replaced, they are incorrectly inserted or the shutter operation mode selector is set to " X " or "B "

## FILM LOADING

Your Chinon CA-4 camera can be used with any type of 35mm film.



1. Pull up the film rewind knob until the camera back pops open (Fig. 5).

2. Then, insert a film cartridge into the film chamber with the protruding end facing the bottom of the camera (Fig. 6).



3. Push in the film rewind knob and slightly turn the knob in either direction until it catches the film cartridge spool.
4. Insert the trimmed end of the film into a slot of the multi-slotted take-up spool.
5. Turn the shutter operation mode selector to the " X " position and advance the film while holding the film lightly down onto the transport sprockets.
6. Release the shutter if necessary and advance the film until the sprockets engage with the upper and lower perforation of the film (Fig. 7)
7. Close the camera back firmly until it locks with a click.
8. Turn the film rewind knob gently until the film slack is taken up and the rewind knob stops. Do not force or further rewind the film.



9. Advance the film and release the shutter three times ((Fig. 8). The rewind knob should rotate counterclockwise when the film is advanced and the "1" marking should appear in the frame counter window (Fig. 9).
10. Turn the shutter operation mode selector to the "AUTO" position and start to take pictures (Fig. 10).

## MEMO HOLDER

Your Chinon CA-4s camera has a built-in memo holder feature. To utilize the memo holder feature, simply cut off the top of the film box and insert it into the memo holder located on the back cover of your camera. This will enable you to quickly and easily identify the type of the film and the ASA speed used in your camera (Fig. 11).



## FRAME COUNTER

Your Chinon CA-4 /4s is equipped with a frame counter which displays the number of exposures and resets automatically

upon opening the camera back. When the camera back is opened, the counter shows " S " indicating the start of the picture taking process.

When film is loaded according to the procedure previously described, the counter displays " 1 " indicating the camera is ready for the first exposure...

Every time the film advance lever is turned the counter will proceed one stop forward. The number 24 and 36 are colored in orange to warn the end of commonly available films (Fig. 12).

The action lamp (LED) located on the front of the camera body will illuminate while the shutter is activated. The subject can easily observe when the shutter is released.

## FILM ADVANCEMENT

Make sure the film has been loaded properly. Operate the film advance lever through a full stroke. When the film end is reached the film advance lever may stop before the lever is fully turned. Do not force the lever! Stop winding at once and rewind the film (Fig. 13). Please refer to "Unloading Exposed Film ".

Note: · When the batteries are dead, you can still use CA-4 / 4s camera. Reset the shutter operation mode selector from "AUTO" to "X" which will provide a shutter speed of 1/100 sec.

## ASA/DIN SETTING

The film speed dial located on the top of the camera is coupled directly to the internal exposure control circuitry. The correct exposure factor for the film is automatically set by aligning the ASA



number of the film you are using with the index mark on the camera body. The ASA number of the film is printed on the film box or the instruction sheet packed with the film.



Turn the film speed dial by lifting up and align the appropriate ASA number with the white index mark. Be sure to check the ASA number whenever you put a new film into the camera (Fig. 14).

ASA										250	320		500	640		1000	1250		2000	2500		
	25	32	40	50	64	80	100	125	160	200	•	•	400	•	•	800	•	•	1600	•	•	3200
DIN	15	16	17	18	19	20	21	22	23	24	25	26	27	28	29	30	31	32	33	34	35	36

## FOCUSING

Your Chinon CA-4 / 4s has three built-in focusing aids.

1. The center of the viewfinder is split image with a microprism collar which is surrounded by ground glass. When the camera is in focus, the image of these focusing aids become sharpest. While observing the subject through the viewfinder, rotate the lens focusing ring until the upper and lower split image match up to form one uniform image (Fig. 15). This split image focusing is particularly helpful when the subject is dominated by vertical lines.

2. The microprism is also helpful. When it is out of focus, the image on the microprism will be composed of a collection of asterisks (Fig. 16). These sparkling asterisks will disappear when the focus is properly adjusted. You can double check the focus setting by the image on the



3. You can also focus indirectly. Actually measure or estimate the camera-to-subject distance and set the lens focusing ring to the appropriate setting (Fig. 17).

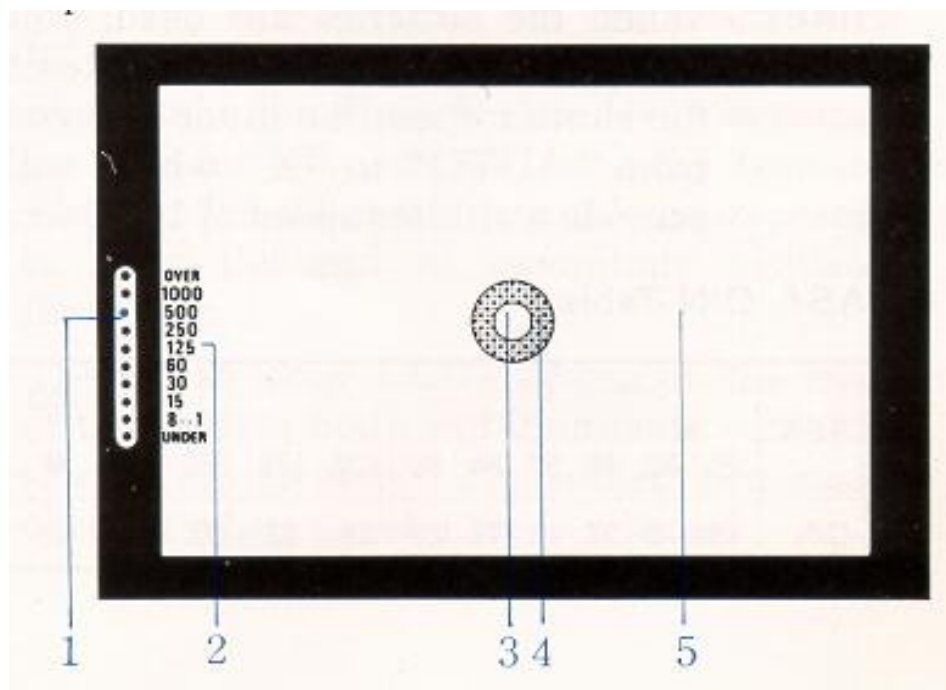

1: Shutter speed indicator/ Flash ready lamp (LED)

2. Shutter speed scale (ground glass)

3. Split-image range finder spot

4. Microprism ring

5. Fine matte outer field

## AUTOMATIC EXPOSURE

Your CA-4 /4s camera features TTL, center weighted full aperture light measuring automatic exposure control. As long as the shutter operation mode selector is set to "AUTO", you do not have to worry about the exposure factor (Fig. 18).

The sensitive and accurate internal circuitry will compute the correct exposure for the photographic condition and control the shutter speeds steplessly from an 1 second time exposure to a fast 1/1000 second.

When the shutter release button is depressed halfway, the exposure control circuit is energized and will be in the monitoring stage (Fig. 19). You can see the computerized shutter speed displayed in the viewfinder by a red LED (Fig. 20). If the lens F stop or the aperture size is too large for the lighting condition, the over exposure indicator at the top of the scale will flash (Fig. 21). When this happens,

stop down the lens diaphragm by turning the lens F stop ring or use a film with a lower ASA number.

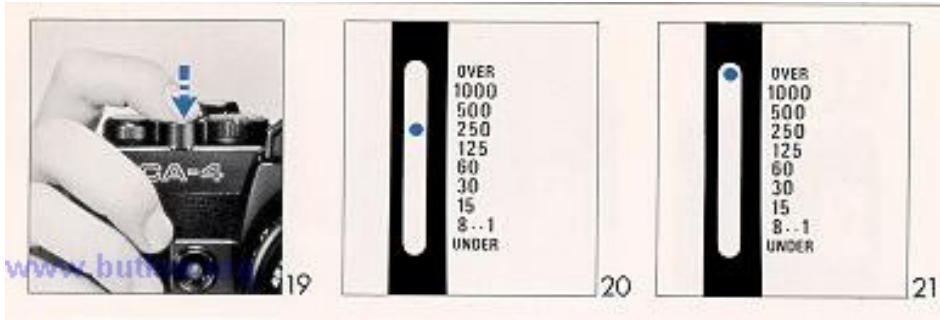

Another alternative is to use a ND filter in front of the lens. They are available as accessories from your local camera store.

If the displayed speed is 1/30 sec. or slower, use of a tripod is recommended. Or you can increase the shutter speed by opening the lens diaphragm. Use of a flash unit is also suggested. Please refer to "Chinon dedicated flash system".

If the computed shutter speed is even longer than one second (semi-darkness condition), the under exposure indicator at the bottom of the scale will light up and flash when the available light is less than - 2EV (Fig. 22).

Note: F stop selection: The following may be used as a guide to determine the lens F stop when you are using the camera; Sunny day outside . . . F/8 -F/16  
Cloudy day outside . . F/4 - F/5.6  
Inside . . . . . F/1.9 - F/2.8 (without flash)

## SHUTTER RELEASE

Your Chinon CA-4 /4s features a two-stage shutter release with a safety cover to prevent accidental shutter release or battery drain. When the shutter release button is depressed halfway, the electronic circuit starts functioning.



When the button is fully depressed, it will trigger the shutter. Always hold the camera steady and gently depress the shutter release button to make an exposure.

## UNLOADING EXPOSED FILM

When the film in the camera is fully exposed the film advance lever will stop.

Do not attempt to force the lever any further. Rewind the film and replace with new film. Push in the rewind button at the bottom of the camera (Fig. 23). Unfold the rewind crank of the rewind knob and turn the rewind crank clockwise (Fig. 24).

You will feel friction as the film is rewound. Suddenly, when the film is rewound completely, the friction will decrease, then lift the rewind knob to open the camera back (Fig. 25).

When the camera back is opened, the frame counter will automatically reset to the " S " position. The rewind button on the bottom of the camera will pop out upon the next advancement of the film advance lever.

Note: Your exposed film should be processed without delay.

## CONVENIENT FEATURES: INTERCHANGEABLE LENSES



Your Chinon CA-4 / 4s camera is equipped with a Chinon bayonet mount which accepts all interchangeable lenses with the universal bayonet mount. To remove the lens from the camera body, depress and hold the lens lock release lever on the camera body, turn the lens counterclockwise as far as it will go, and lift it up from the body (Fig. 26).

Note: Do not remove or replace the lens while the camera is functioning...



To attach the lens, match the red dot on the camera body with the red dot on the lens (Fig. 27). Then insert the lens into the camera body and turn it clockwise until the lens locks with a click.

## CHINON DEDICATED FLASH SYSTEM

Specially designed and developed automatic flash units are available for your Chinon CA-4 / 4s camera as optional accessories. This highly advanced dedicated flash system permits carefree flash photography. You no longer have to alter the shutter operation mode selector from the " auto " position since the flash is integrated electronically with the camera body.

Set the f/stop indicated on the exposure calculator dial of your Chinon flash to the corresponding aperture ring on the lens. A few seconds after your Chinon flash is turned to the " on " position, the flash ready light will illuminate. Your Chinon CA-4 / 4s has a special viewfinder ready-light system which is electronically coupled to the auto flash.

When the flash has reached adequate power, the viewfinder 1/60 sec. shutter speed indicator (LED) will flash signaling the camera and flash are ready to operate (Fig. 28)

After the picture has been taken and before the flash has recycled, the camera will automatically switch to the automatic mode until the flash has once again recycled. In this case, your flash must be set to the " AUTO " position. Stop at your Chinon dealer today to get a complete demonstration of Chinon quality automatic electronic flashes they will light up your life!





Other electronic flash units can be utilized with your Chinon CA-4s camera. However, the shutter operation mode selector must be set to the "X" flash synchronization position. Always refer to the instructions enclosed with your electronic flash for additional operating instructions.

Model	Chinon Auto S-180	Chinon Auto S-240	Chinon Auto S-280
1. Type:	Automatic Flash	Thyristor Electronic Flash (power cut-off system)	Thyristor Electronic Flash (power cut-off system)
2. Auto Flash System:	YES	Yes	Yes
3. Dedicated for CA-4 /4s camera:	NO	Yes	Yes
4. Guide Number in M . ASA 100 . ASA 400	16 36	24 48	28 56
5. Setting: . ASA 100 . ASA 400	One aperture setting F4 F8	Two aperture settings F4/F8 F8/F16	Two aperture settings F4/F8 F8/F16
6. Manual Flash:	YES	Yes	Yes
7. Auto-operation: F4 ( SA 100)  F8 SA 400)  F8 (ASA 100) 1  F16 (ASA 400)1	1m - 4.5M (3.28ft - 14.7ft)	0.7m - 6m (2.3ft - 19.6ft) 0.7m - 3m (2.3ft - 9.8ft)	0.7m - 7m (2.30 - 22.9ft) 0.7 - 3.5m (2.3ft - 11.4ft)
8. ASA Range:	25 - 400	25 - 400	25 - 400



9. Sensor Acceptance Angle	Approx. 20 degrees <small>www.orphancameras.com</small>	Approx. 20 degrees	Approx 20 degrees
10. Flash Duration:			
Auto	1/3000 - 1/1500	1/3000 - 1/750	1/3000 - 1/750
Manual	1/1500	1/750	1/750
11. Recycling Time:			
Auto	10 sec.	0.5 - 10 sec.	0.5 - 10 sec.
12. Number of flashes: (Alkaline batteries)	Approx. 150 on manual	Approx. 200 on manual	Approx. 150 on manual
13. Bounce capability:	NO	NO	Yes
14. Illumination Angle:	for 35mm lens	for 35mm lens	for 35mm lens
15. Power Source:___	Two AA batteries	Four AA batteries	Four AA batteries
16. Open Flash Button	Yes	Yes	Yes
17. Sync. Jack:	Yes	Yes	Yes
18. Dimensions:	51x69x82mm	58x77x85mm	56x133x77mm
19. Weight:	160g	210g	250g

## DEPTH OF FIELD

Depth of field designates the nearest and furthest limits of the area that will be sharp in the picture in front of and beyond the subject. The larger the lens opening, the shallower is the depth of field. The smaller the lens opening; the greater the depth of field becomes (Fig. 29 & 30).



### Depth of Field Scale:

The depth of field scale indicates (after focusing) the approximate area that will be sharp in the picture. Locate on the depth of field scale the corresponding pair of f/stop figures. The distance between these two f/ stop figures on the focusing ring will be the area of sharpness in your picture (Fig. 31).

## SELF-TIMER

The self-timer when set, trips the shutter mechanism after a delay of 7-12 seconds. This feature is useful should the photographer wish to be included in the picture, and is also useful for taking pictures at slow shutter speeds when a cable release is not available.

When using the self-timer, the camera must be mounted on a tripod, or a solid support of some kind...

To operate, move the self-timer lever counterclockwise as far as it will go. Advance the film transport lever. Upon pressing upward on the self-timer lever with your finger, the self-timer mechanism will start to operate (Fig. 32).

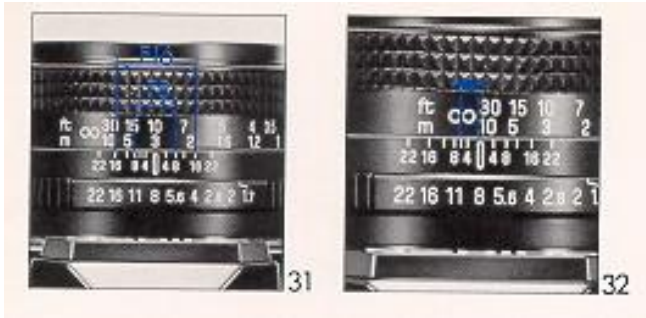

Note: Do not depress the shutter release button, since the self-timer mechanism will not operate and the shutter will be released instantly.

Do not advance the film transport lever until the self-timer operation completely stops.

## INFRA-RED PHOTOGRAPHY

Your CA-4 / 4s camera accepts infra-red film. To use infra-red film an extra focusing adjustment must be made. After focusing note the figure that is adjacent to the green marking on the distance scale of the lens (Fig. 33), then move that figure over to the infra-red mark engraved on the lens. This adjustment is only required for black and white infra-red film. When using a color infra-red film, you should focus in the normal way.

Note: Read the instructions carefully packed with the infra-red film for further information.

## CARE OF THE CAMERA

Your Chinon CA-4 / 4s camera is a precision instrument. Used with care, it will provide years of trouble free service. Protect your camera from dirt, rain, dampness and excessive heat. Avoid touching the lens. To clean the lens, wipe it gently with a soft lint less cloth or lens tissue. Do not use eyeglass tissue as it might damage the lens coating.

### \* Standard Lenses

45mm t/2.8 50mm f/1.9

**f/1.7 multicoated**

[www.orphancameras.com](http://www.orphancameras.com)

**f/1.4 multicoated**

**\* Wide-angle lenses**

**28mm f/2.8 multicoated 35mm f/2.8 multicoated**

**\* Telephoto lenses**

**135mm f/2.8 multicoated**

**200mm f/3.5 multicoated**

**300mm f/5.6 multicoated**

**500mm f/8 multicoated**

**\* Zoom lenses**

**28 - 50mm f/3.5 - 4.5 multicoated**

**35 - 100mm f/3.5 - 4.3 multicoated**

**80-200mm f3.8 multicoated**

**\* Accessories**

**Auto Flash S-180**

**Auto Flash S-240**

**Auto Flash S-280**

**Synchro-eye for flash (slave unit)**

**Deluxe carrying case**

**Filter 49mm (Skylite, UV, ND4X, Y2, PL)**

**Rubber eyepiece**

**Eyepiece adapter ( - 3, +1, +3)**

**Rubber lens hood**

[www.orphancameras.com](http://www.orphancameras.com)

**Auto extension ring**

**Bellows**

**Minicopy stand**

**Spare ring for mini-copy stand**

**Cable release adapter (13 inch, 20 inch)**

**Angle finder**

**Table tripod**

**Neck Strap**

**1.5V silver oxide battery (3 pcs. in one set)**

**3 clips lens cap**

**Eyepiece cover**

**Body cap**

**and many more**