

Cosina 107-SW

This camera manual library is for reference
and historical purposes, all rights reserved.

This page is copyright© by mike@butkus.org

This page may not be sold or distributed without
the expressed permission of the producer.

I have no connection with
any camera company , M. Butkus, NJ.

On-line camera manual library
This is the full text and images from the manual.

**If you find this manual useful,
how about a donation of \$3 to:**

M. Butkus, 29 Lake Ave.,
High Bridge, NJ 08829-1701
and send your e-mail address
so I can thank you.

Most other places would charge
you \$7.50 for a electronic copy
or \$18.00 for a hard to read Xerox copy.

This will help me to continue to host this site,
buy new manuals, and pay their shipping costs.

It'll make you feel better, won't it ?

**If you use Pay Pal, use the link below.
Use the above address for a check, M.O. or cash.**



[Click here for Camera Manual site](#)

www.butkus.us

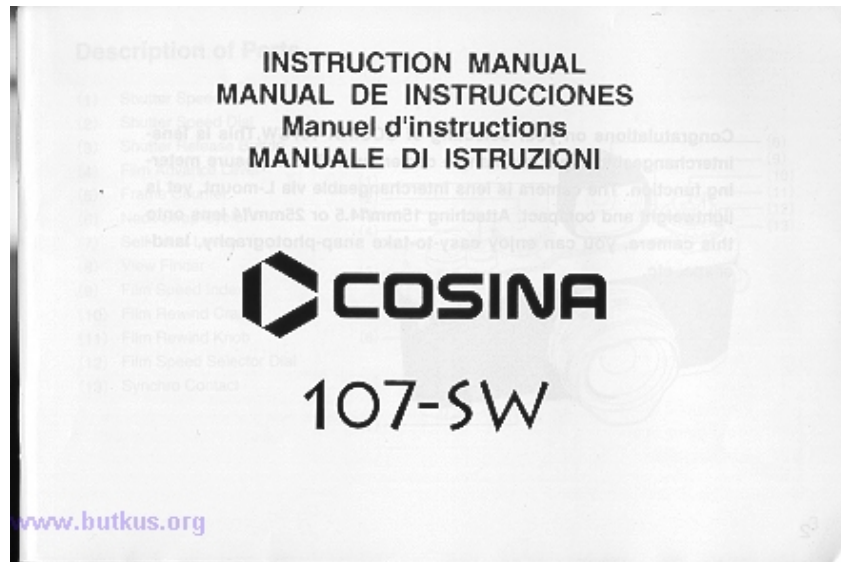

Congratulations on your selecting of COSINA 107SW. This is lens interchangeable super wide-angle camera with TTL exposure metering function. The camera is lens interchangeable via L-mount, yet is lightweight and compact. Attaching 15mm/f4.5 or 25mm/f4 lens onto this camera, you can enjoy easy-to-take snap-photography, landscape, etc.

Description of Parts

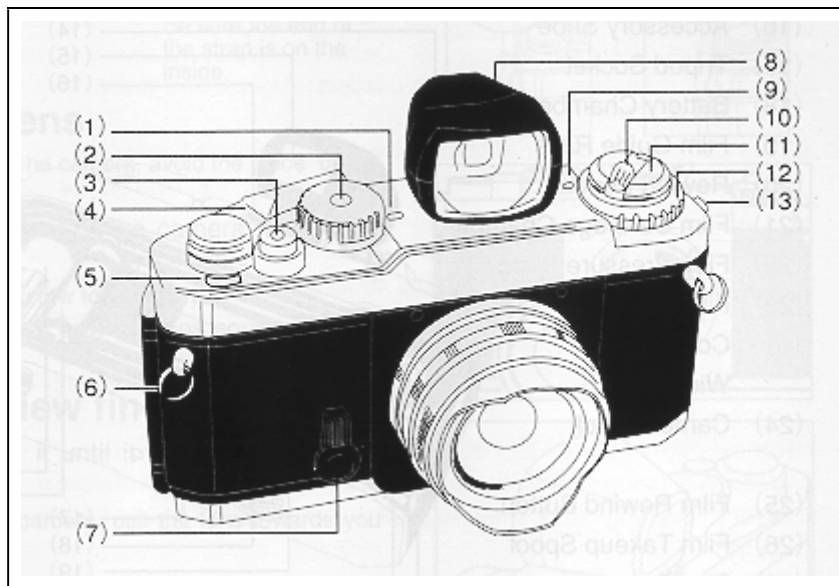

- (1) Shutter Speed Index
- (2) Shutter Speed Dial
- (3) Shutter Release Button
- (4) Film Advance Lever
- (5) Frame Counter
- (6) Neck Strap Eyelet
- (7) Self-timer Lever
- (8) View Finder
- (9) Film Speed Index
- (10) Film Rewind Crank
- (11) Film Rewind Knob
- (12) Film Speed Selector Dial
- (13) Synchro Contact

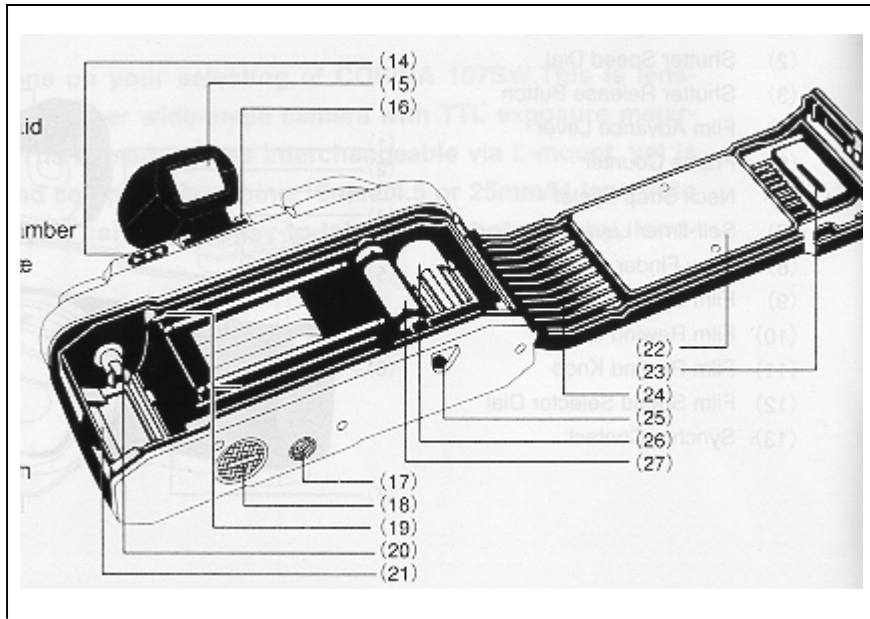

- (14) LED Lamps
- (15) Viewfinder Eyepiece
- (16) Accessory Shoe
- (17) Tripod Socket
- (18) Battery Chamber Lid
- (19) Film Guide Rails
- (20) Rewind Fork
- (21) Film Cartridge Chamber
- (22) Film Pressure Plate
- (23) Film Cartridge
- (24) Camera Back
- (25) Film Rewind Button
- (26) Film Take-up Spool
- (27) Film Sprockets

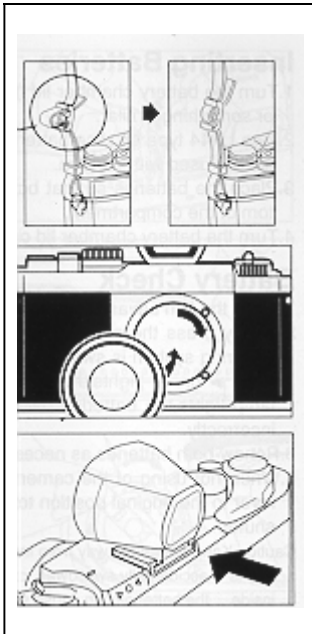

Attaching Neck-strap

Attach the neck-strap to the camera as illustrated right:

Attaching/detaching Lens

To detach or attach the lens from / to the camera, avoid the place under direct sunshine.

1. Align the lens mount screw with that of the camera, then, turn the lens clockwise.

Pay attention not to tighten the lens screw too strongly.

2. To detach the lens from the camera, turn the lens counter-clockwise.

Attaching/detaching View finder

Attach the view finder by inserting it until it firmly clicks on the camera's accessory shoe.(16)

When detaching the lens from the camera, pull the lens towards you straightly not to turn it forcibly.

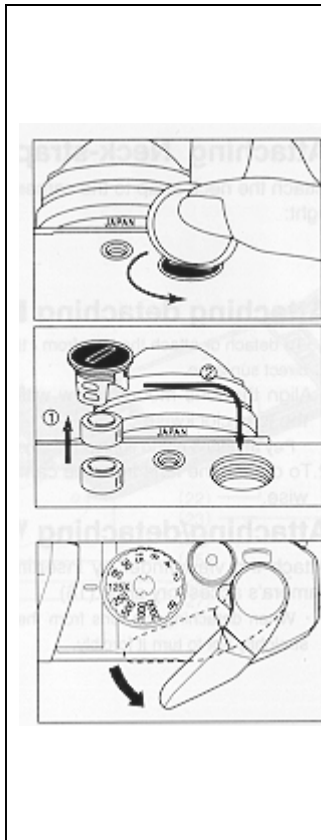

Inserting Batteries

1. Turn the battery chamber lid (18) counterclockwise using a coin or something similar.
2. Two LR44 type alkaline batteries or two SR44 type silver batteries are used with camera.
3. Place the batteries so that both positive(+)sides are at the bottom of the compartment.
4. Turn the battery chamber lid clockwise until it close firmly.

Battery Check

1. Move the film advance lever (4) to the ready position.
2. Lightly press the shutter release button(3). Now the exposure metering system is switched on. When one of three LED lamps (• , ▶ or ◀) lights, then battery condition is satisfactory. If no lamp lights, the batteries need replacing or have been loaded incorrectly.

3. Renew both batteries as necessary.

4. When not using of the camera, always return the film advance lever to the original position to prevent accidentally releasing the shutter.

Caution: Keep batteries away from infants and small children. In case a battery is accidentally swallowed, call a doctor immediately as the material inside the batteries can cause serious problems.

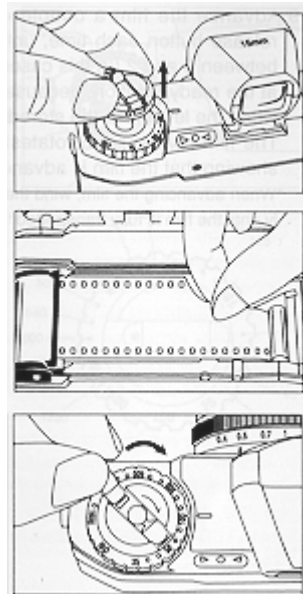

Loading Film

1. To open the camera back(24), pull Film rewind knob (11) out. When the back cover opens, the frame counter(5) automatically resets to "S".
2. Insert the film cartridge into the film chamber so that the projecting end of the film cartridge is downward. Do this in a place away from direct sunlight.
3. Fold out and lift up the film rewind crank(10). Then rotate the crank carefully while push in it down lightly until the film locks on the film rewind fork(20).
4. return the film rewind knob to its original position.
5. Insert the film leader into the groove of the film takeup spool (26) and place it so that the film perforations engage with the spool teeth.

6. Check that the film perforations engage properly with the teeth of Film sprockets (27) and the film slides smoothly along the film guide rails (19) by operating lightly the film advance lever (4) to advance the film.

Caution: Do not touch the shutter curtains.

7. Turn the film rewind crank gently in the direction of the arrow to properly tension the loaded film. Stop turning the crank when it becomes stiff, and return the crank to its original position.

8. Gently close the back cover and push it until it clicks.

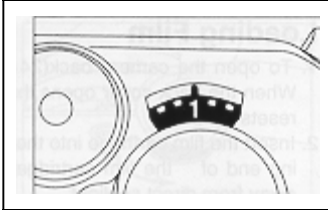

9. Advance the film a couple of frames, pressing the shutter release button each time, until the frame counter indicates "1" between 0 and 2. (In this case, the film advance lever should be at the ready position, because the shutter release is interlocked when the lever is in the stored position).

The film rewind knob rotates each time the film is advanced showing that the film is advancing properly.

When advancing the film, wind the film advance lever slowly and secure until the film is fully transported to the next frame.

FILM SPEED SETTING

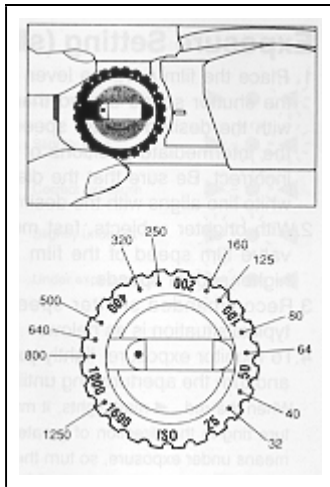

1. Filmspeed is indicated on the outside of film package, in the film instructions or on the film cartridge.

2. Set Film speed Selector Dial (12) so that Film speed index(9) indicates the value on Film speed Selector Dial corresponding to the film used. For example, if film speed shown on the film is ISO 100/21 , set the Film speed Selector Dial to the 100 on the dial matches with the index.

3. Click points are provided at each step of film speed on the Film speed Selector Dial. When setting the film speed, make sure that it clicks.

Exposure Setting (shutter speed priority)

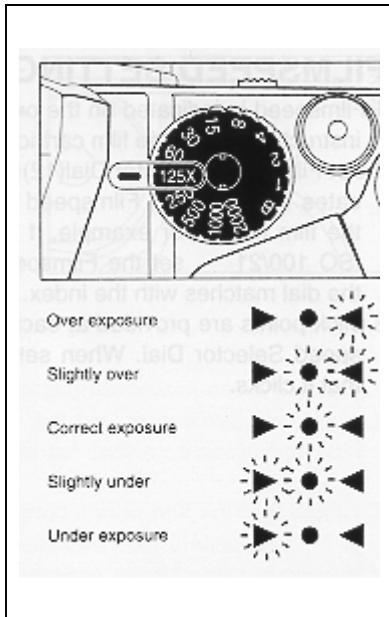

1. Place the film advance lever (4) in the ready position and turn the shutter speed dial so that the indicator white line aligns with the desired shutter speed value. Then if the dial is set at the intermediate positions of the index, shutter speed will be incorrect. Be sure that the dial clicks at the position where the white line aligns with the desired value.

2. With brighter subjects, fast moving subjects or with the higher value film speed of the film used, it is recommended to use higher shutter speeds.

3. Recommended shutter speed with ISO 100/21 film under typical situation is as below:

4. To monitor exposure, lightly press the shutter release button (3) and turn the aperture ring until the green · mark lights.

When the red left arrow ◀ mark lights, it means over exposure. So turn the aperture ring in the direction of greater f/value. If the red right arrow ▶ mark lights, it means under exposure, so turn the aperture ring to a smaller f/value.

Note: Outside the exposure metering range of your camera (EV 4 to EV19), the exposure meter will not function properly and the green LED indicator may come on indicating incorrect exposure.

Subject	Shutter speed
Stationary subject in subdued Light	1~1/15
Indoors in normal conditions	1/30~1/60
Outdoors on a fine day	1/125~1/250
Seaside in midsummer	1/500~1/2000
Mountain area with snow	1/500~1/2000
Fast moving subjects	

Exposure Setting (aperture priority)

1. Place the film advance lever (4) in the ready position and turn the aperture ring until the index on the lens barrel indicates the desired f/value.

2. The suitable aperture value changes according to the brightness of the subject, the depth-of-field desired or filmspeed of the film in use, and typical settings of the aperture with ISO 100/21 film are as below.

3. Click points are provided each step of filmspeed on the Filmspeed Selector Dial. When setting the film speed, make sure that it clicks.

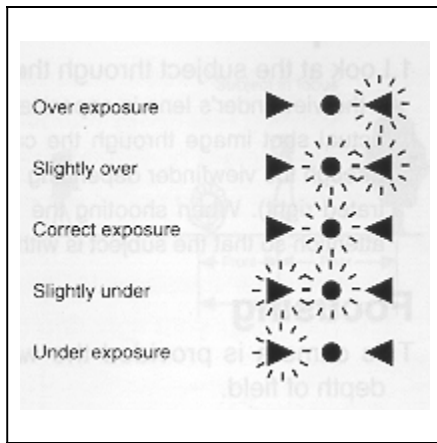

3. To monitor the exposure, lightly press the shutter release button (3) and turn the shutter speed dial until the green · mark lights. If the red left arrow ◀ mark lights, turn the shutter speed dial to the higher shutter speed setting and if the red right arrow ▶ mark lights, then turn the shutter speed dial to the lower shutter speed setting.

When the green · mark lights at intermediate positions between click, first set the dial at a click on either side and make fine control by operating the aperture ring afterwards.

Note: Outside the exposure metering range of your camera (EV 4 to EV 19), the exposure meter will not function properly and the green LED indicator may come on indicating incorrect exposure.

Subject f/value

Indoors in normal conditions F/4 to F/5.6

Outdoors on a cloudy day F/4 to F/8

Outdoors on a fine day F/8 to F/11

Seaside in midsummer F/11 to F/16

Mountain areas with snow F/11 to F/16

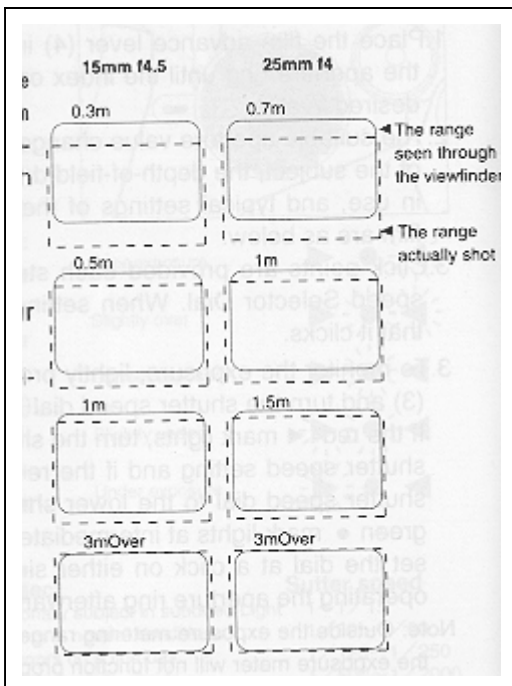

Composition

1. Look at the subject through the view finder.

As the viewfinders lens is separated from the cameras shooting lens, the actual shot image through the camera lens may differ from that seen through the viewfinder depending on the distance to the subject (as illustrated right). When shooting the subject is at near distance, pay much attention so that the subject is within the frame.

Focusing

This camera is provided the wide-angle lens offering a greater depth of field.

Turn the distance ring of the lens until it aligns with the approximate distance to the subject on the distance index.

Depth-of-field

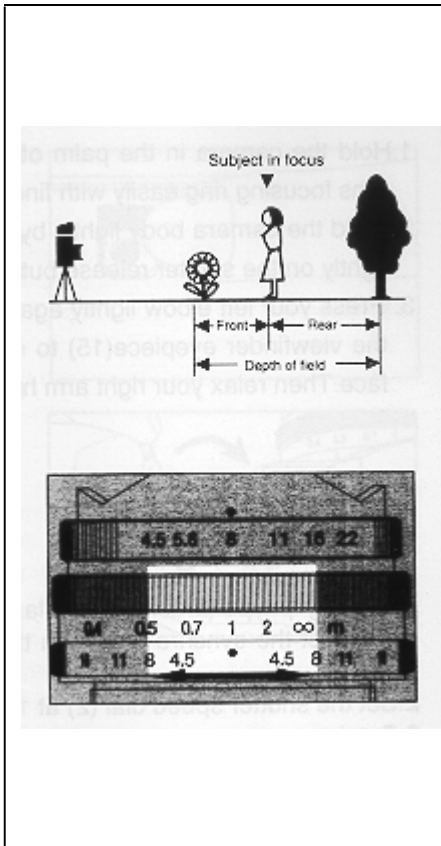

1. When you are focusing on a given subject, objects in the foreground and background will appear acceptably sharp in the picture. The range in which all objects appear acceptably sharp in the picture is called "depth-of-field."

2. To obtain the depth-of-field range at different aperture settings, the depth-of field scale is used.

The distance covered by the range between pairs of the same f/stops on the depth-of-field scale as the f/value used is the depth-of-field. To obtain the actual distance values of the depth-of-field, read the values within the range of the focusing scale.

3. For instance, when the lens is focused on a subject at a distance of 1 m with the aperture set at f/8 the depth-of-field can be obtained by using the depth-of-field scale as follows: the values on the distance scale corresponding with the f/values shown on the depth-of-field scale are approximately 0.5m and infinity respectively. This means that all objects within the range between 0.5m and infinity distance can be reproduced acceptably sharp in the picture with the aperture set at f/8.

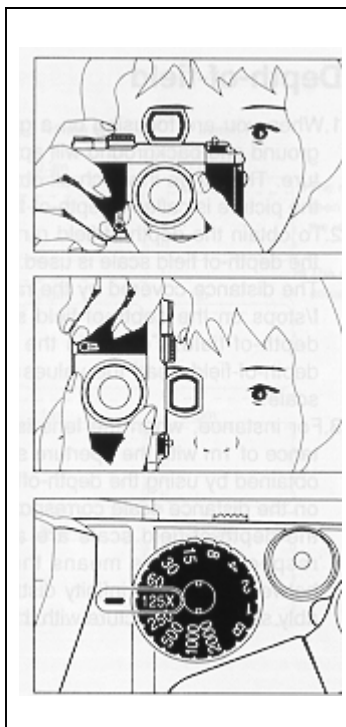

Holding Camera

1. Hold the camera in the palm of the left hand so as to turn the lens focusing ring easily with fingers.
2. Hold the camera body lightly by and place your right fore finger lightly on the shutter release button.
3. Press your left elbow lightly against your body and look through the viewfinder eyepiece (15) to 'steady the camera against your face. Then relax your right arm holding the grip.

Flash Photography

Use the grip type (bracket type) flash unit.

1. Connect the synchro cord with the synchro contact of the camera.
2. Set the shutter speed dial (2) at 1/125 second or lower.
3. Set the aperture

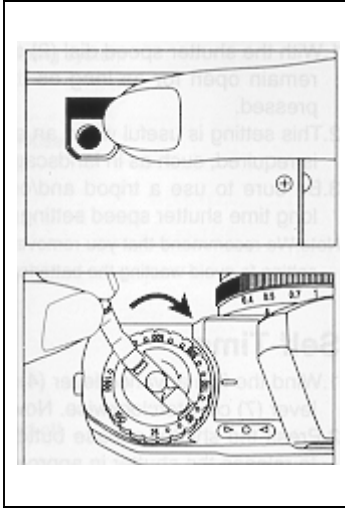

Rewinding the Film

1. When the film is at its end, the advance lever no longer operates smoothly, check the frame counter (5) display. If the frame counter shows that the all frames of the loaded film have been exposed, the film then needs to be rewound.
2. Press the film rewind button (25) on the camera base.
3. Fold out the film rewind crank (10) and turn it in the direction of the arrow.
4. Once the pressure eases, the film is completely wound into the cartridge.

5. Lift up the film rewind knob (11) and pull it out to open the camera back (24). Now the film cartridge can be taken out.

6. Do this in a place away from direct sunlight.

Note: If the film reaches the end of the roll during film advance, the film advance lever will lock. Rewind the entire roll, then complete the movement of the film advance lever and put it back into place.

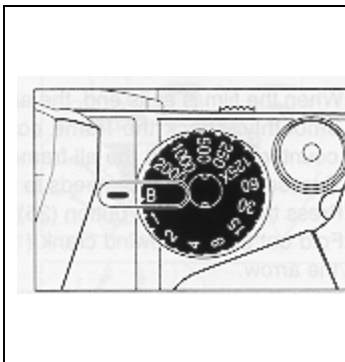

" B" (bulb) Setting

1. With the shutter speed dial (2) set at "B" position, the shutter will remain open for as long as the shutter release button (3) is pressed.
2. This setting is useful when an exposure longer than one second is required, such as in landscape photography at night.
3. Be sure to use a tripod and/or cable release when using this long time shutter speed setting.'

Note: We recommend that you remove the Batteries from the camera at this setting to avoid wasting the batteries.

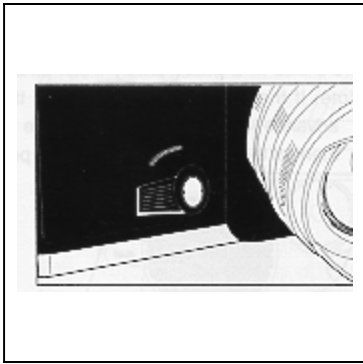

Self-Timer

1. Wind the film advance lever (4) and fully turn down the self-timer lever (7) counterclockwise. Now the self-timer is ready to use.
2. Press the shutter release button (3) and the self-timer operates to release the shutter in approximately 10 seconds later.
3. Once the self-timer becomes ready it is impossible to cancel it manually. So operate it only when needed.

4. The self-timer is very useful when you wish to include yourself in a picture, or, you can use it in order to prevent Camera shake in shutter releasing instead of using the cable release.

Specifications

Type: 35mm camera with focal plane shutter and TTL metering system

Film Format: 35mm film, 24x36mm

Lens Mount: L-mount

Shutter: Vertically moving metal focal plane shutter B, 1-1/2000sec.

Self-Timer: Mechanical self-timer with 10 sec operating time

Exposure display:	Red left arrow ◀ mark LED Over exposure warning
	Green ● mark LED Good exposure indication
	Red right arrow ▶ mark LED Under exposure warning

Exposure Metering System: Center-weighted average metering by pressing Shutter Release Button

Exposure Coupling Range: EV4-19 (ISO 100. F4,1sec. - F16, 1/2000sec.)

Flash Terminal: X synchro contact Synchronized at 1/125 sec or lower speed

Film Advance: By single-lever action with 135 throw and 30 stand-off

Film Rewind: By film rewind button and film rewind crank

Frame Counter: Additive type with autoreset by opening the back cover

Film Speed Range: ISO 25-1600 by 1/3 steps

Power Source: Two 1.5V Alkaline batteries (LR44) or Silver batteries (SR44) –

Dimensions: 135.5(W) 78.5(H) 33.5(D)mm

Weight: 320g

These specification and external appearance are subjected to change for improvement without prior notice.