

Konica TC-X

posted 5-11-'03

This camera manual library is for reference
and historical purposes, all rights reserved.

This page is copyright by mike@butkus.org, M. Butkus, NJ.

This page may not be sold or distributed without
the expressed permission of the producer

I have no connection with any camera company

On-line camera manual library

If you find this manual useful, how about a donation of \$3 to:

M. Butkus, 29 Lake Ave., High Bridge, NJ 08829-1701

and send your e-mail address so I can thank you.

Most other places would charge you \$7.50 for a electronic copy
or \$18.00 for a hard to read Xerox copy.

This will help me to continue to host this site,
buy new manuals, and pay their shipping costs.

It'll make you feel better, won't it?

If you use Pay Pal, use the link below.

Use the above address for a check, M.O. or cash.

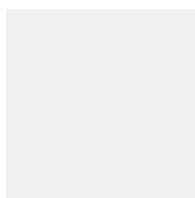

www.PayPal.me/butkus

Venmo @mike-butkus-camera

[Back to main camera manual page](#)



Thank you for your purchase of a Konica TC-X

- (1) The Konica TC-X is a compact, lightweight, fully automatic single lens reflex camera with a shutter-priority through-the-lens automatic exposure system.
- (2) The Konica TC-X is fully compatible with the "DX" system for automatic input of film-speed (ISO) information.
- (3) A high resolution, high-performance Hexanon AR 50mm f/1.8 lens is standard equipment on the Konica TC-X.
- (4) A new design extremely bright viewfinder makes accurate focusing easier, increases visibility of in-finder data.
- (5) Accepts the full range of Hexanon interchangeable lenses and a wide range of Konica accessories, including a electronic flash unit.

*DX: Films designed for use in DX Code System cameras. The Konica TC-X can accept this film.

Konica TC-X specifications

Type: 35mm SLR camera with shutter-priority TTL AE mechanism

Format: 24 x 36mm

Standard lenses: Hexanon AR 50mm f/1.8, Hexanon AR 50mm f/1.4

Lens mount: Bayonet type Konica Mount 11

Aperture control: Fully automatic and manual

Shutter: Vertical transport mechanical focal plane shutter, "B" 1/8--1/1000 sec

Flash sync: X sync at 1/8 through 1/60 sec

Self-timer: 10 sec. delay (approx.)

Viewfinder: Real image eye-level pentaprism Finder with split image range finder, microdiaphragm ring and peripheral matte screen; field of viewfinder is 92 percent 0.87 x with 50mm lens

Finder display: Needle indication of aperture from f/1.4 to f/22, with over and under exposure warnings, manual operation signed, stopped-down metering mark and AE coupling range indication.

Metering system: Through-the-lens center weighted metering at full aperture, CdS cell

Exposure control: Shutter-priority AE mechanism, with standard Hexanon AR lenses, AE mechanism is coupled with film speed, shutter speed and widest lens aperture; correct aperture indication for manual metering, in stopped-down mode, meter coupled with film speed, shutter speed and aperture

AE coupling range: EV5 (f/1.4, 1/15 sec) through EV18 (f/16, 1/1000 sec) for ISO 100

Film speed: ISO 50 through 1600 (1/3 step). Both of automatic setting (DX code film) and manual setting are possible.

Power switch: Turns battery on/off and locks shutter release

AE Lock mechanism: Partial depression of shutter locks AE mechanism (for exposure compensation)

Power source: Single LR03 or R03 dry battery (AAA size)

Film loading: Konica "easy load" system; film check window for DX type **film**

Film advance: Single action top lever, wind angle of 135 degrees, 20 degrees play.

Film rewind: Crank driven rewind mechanism, film rewind button resets automatically

Frame counter: Additive type, auto-reset

Size, weight: Body 130 x 84 x 44mm (5.11 x 3.11 x 1.73"). 375g (13.2 oz) (without battery)

Note: Specifications and design subject to change without notice.

Eight simple steps for photography

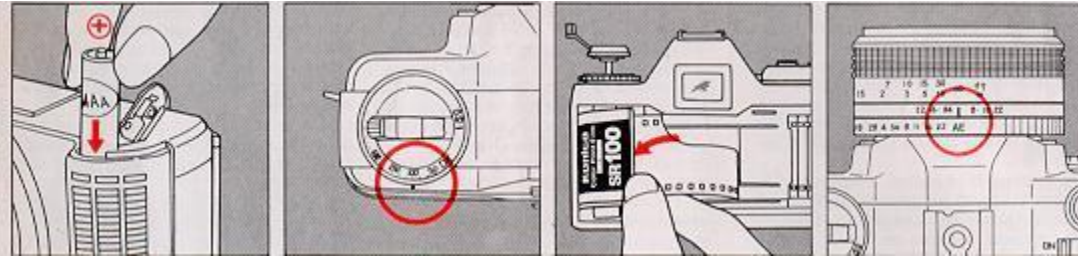

1. Insert battery (p. 12)
2. Set film speed (p. 16)
3. Load film (p. 18)
4. Set "AE" mark (p. 22)

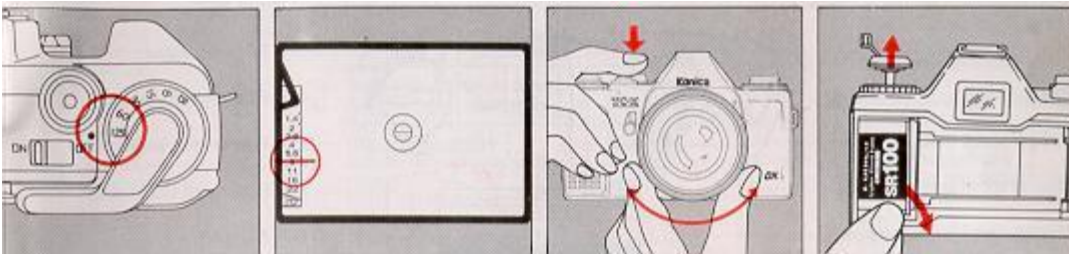

5. Set shutter speed (p. 22)
6. Check exposure and framing (p. 26)
7. Focus and shoot (p. 24)
8. Rewind and unload film (p. 28)

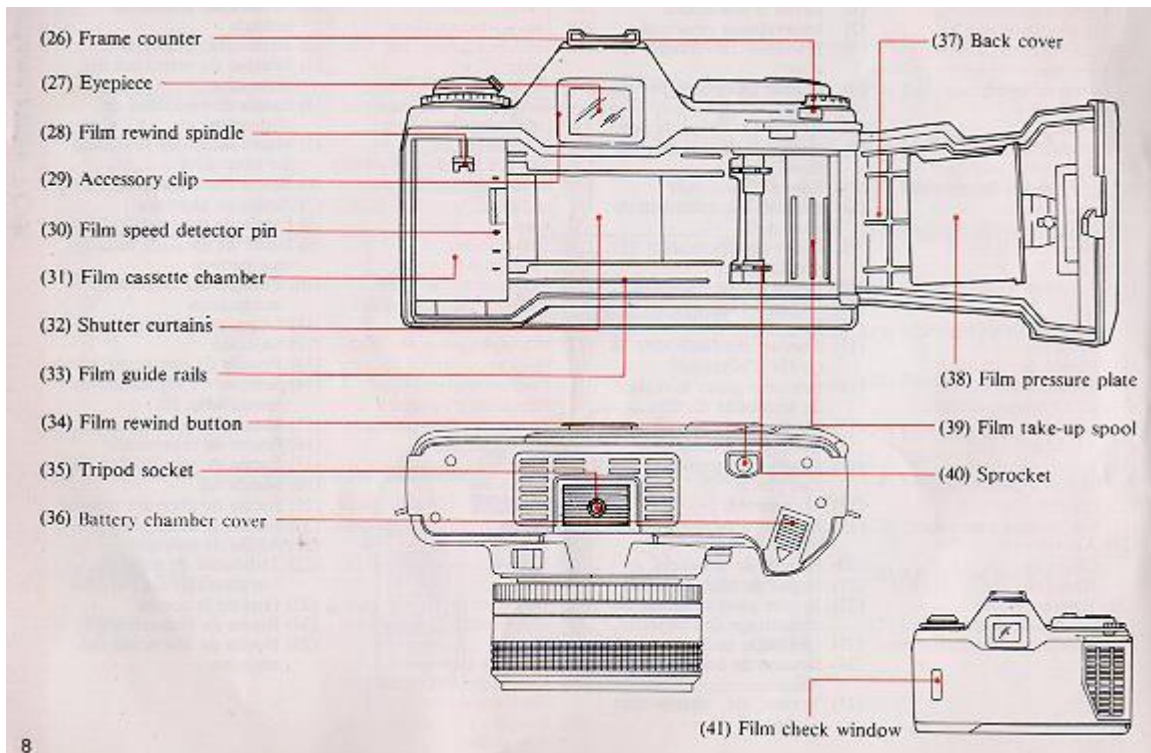
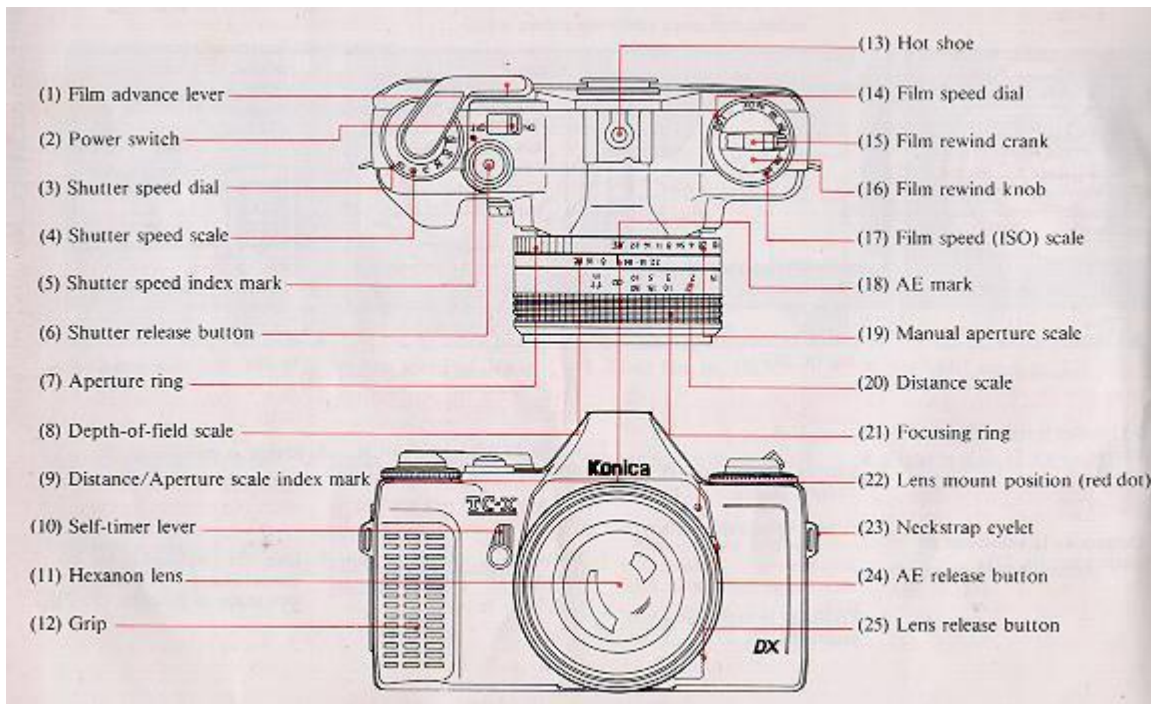

1. Changing the lens

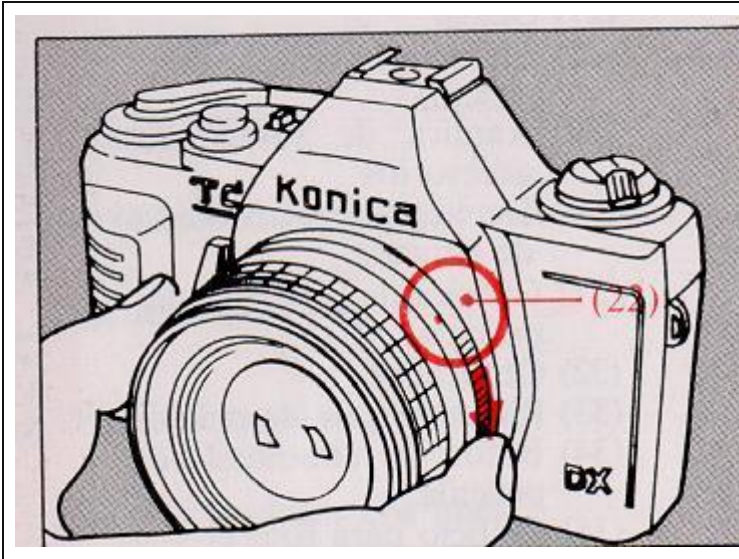

1. Changing the lens Attaching the lens:

Align the red dot on the lens barrel with the red dot (22) on the camera body and gently insert the lens barrel into the camera. Grip the lens and turn clockwise until it locks.

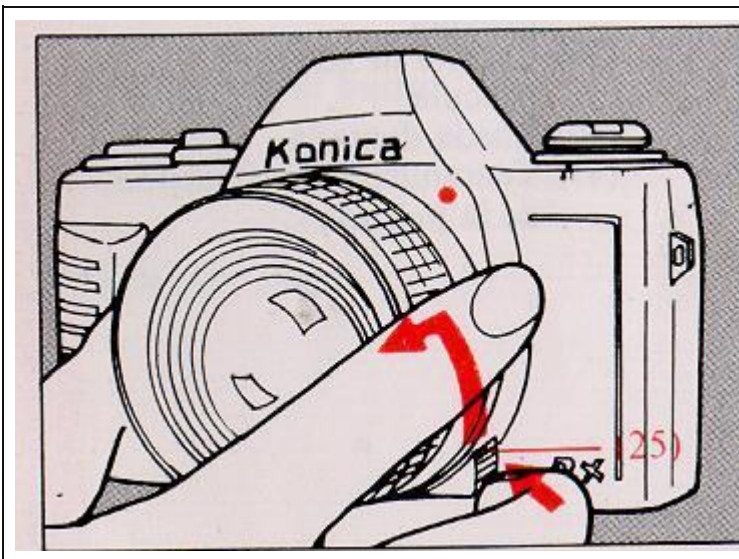

Removing the lens:

While the lens release button (25) is kept depressed, turn the lens barrel counterclockwise until the red dots on the lens and camera are aligned. Then remove the lens.

2. Inserting battery

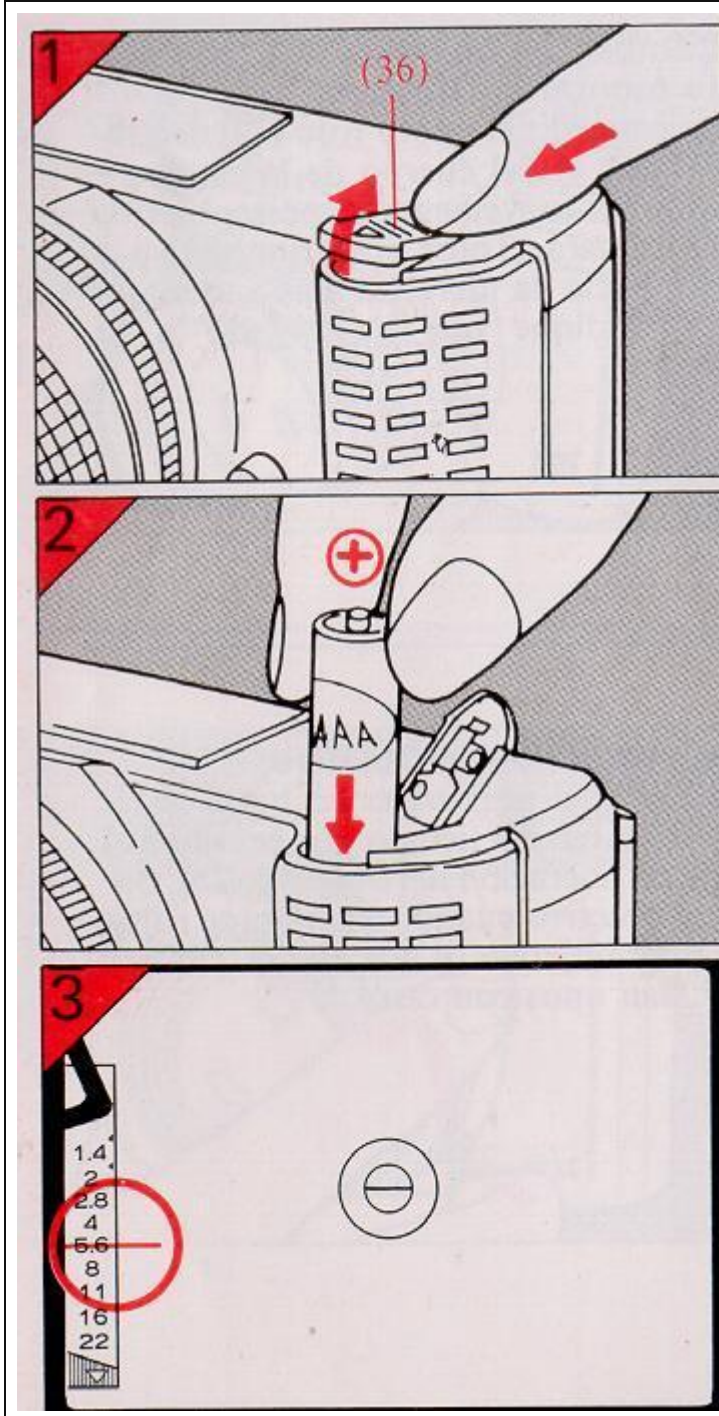

2. Inserting Battery

The Konica TC-X uses a single LR03, R03 dry battery (AAA size) as the power source for the AE system

1) Open the battery chamber cover (36) by pushing the cover in (the direction of the arrow).

2) Place a fresh battery in the chamber, making sure that the "+" and "-" poles of the battery match those in the battery chamber. Close the battery chamber cover.

3) To make sure the battery is working, look through the view-finder with the power switch "on" aiming towards the sky or a light. The AE needle will swing rapidly if the battery is operating.

*Wipe battery with a dry cloth before loading.

*Battery will last about two years with normal use (manufacturer's estimate). When the AE needle does not move even if the camera is aimed at the sky or bright light with power switch "on", replace battery.

3. Power switch

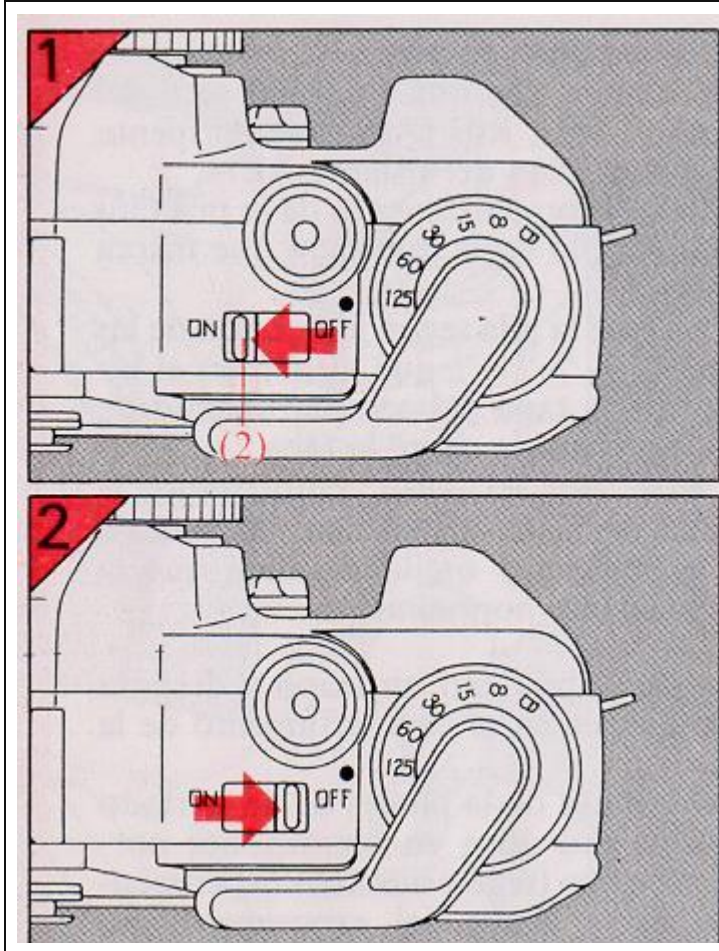

3. Power switch

The power switch functions as the power ON-OFF/shutter release button safety lock system. 1) When the power switch (2) is turned "ON" the light meter is activated and the shutter release is unlocked. 2) When the switch is turned "OFF" the meter is turned off and the shutter release locks.

*When the camera is not in use, power switch should be turned "OFF" to prevent accidental shutter release and prevent drain on battery power.

4. Setting film speed

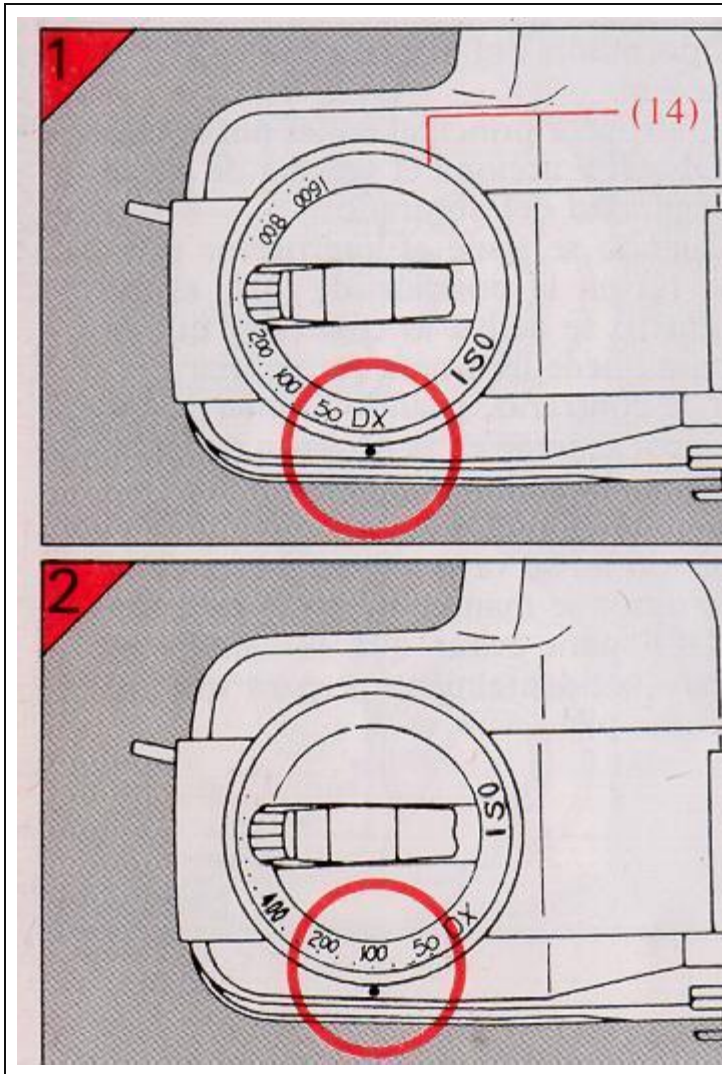

4. Setting film speed

1) When the film speed dial (14) is set at "DX" the camera automatically reads the film speed of the film magazine, so manual film speed setting is unnecessary. This is only effective with "DX" type films.

2) When non-Ding type film is used, turn the film speed dial (14) to set the camera for the rating of the film.

Example of DX symbol on film

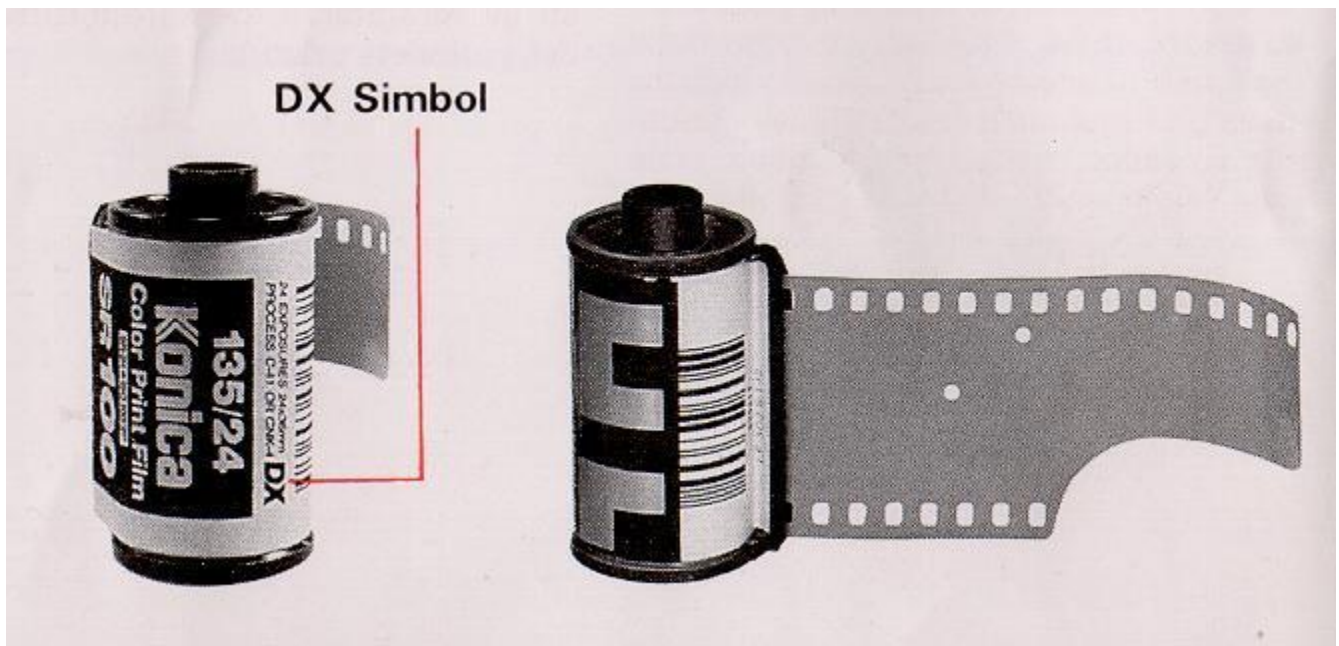

Example of film



ASA / DIN film speeds

Film speed reading ISO/DIN comparison table

ISO/ASA	50	•	•	100	•	•	200	•	•	400	•	•	800	•	•	1600	
	┌	└		┌	└		┌	└		┌	└		┌	└		┌	└
	64	80		125	160		250	320		500	640		1000	1250			
DIN	18	•	•	21	•	•	24	•	•	27	•	•	30	•	•	33	
	┌	└		┌	└		┌	└		┌	└		┌	└		┌	└
	19	20		22	23		25	26		28	29		31	32			

5. Loading film

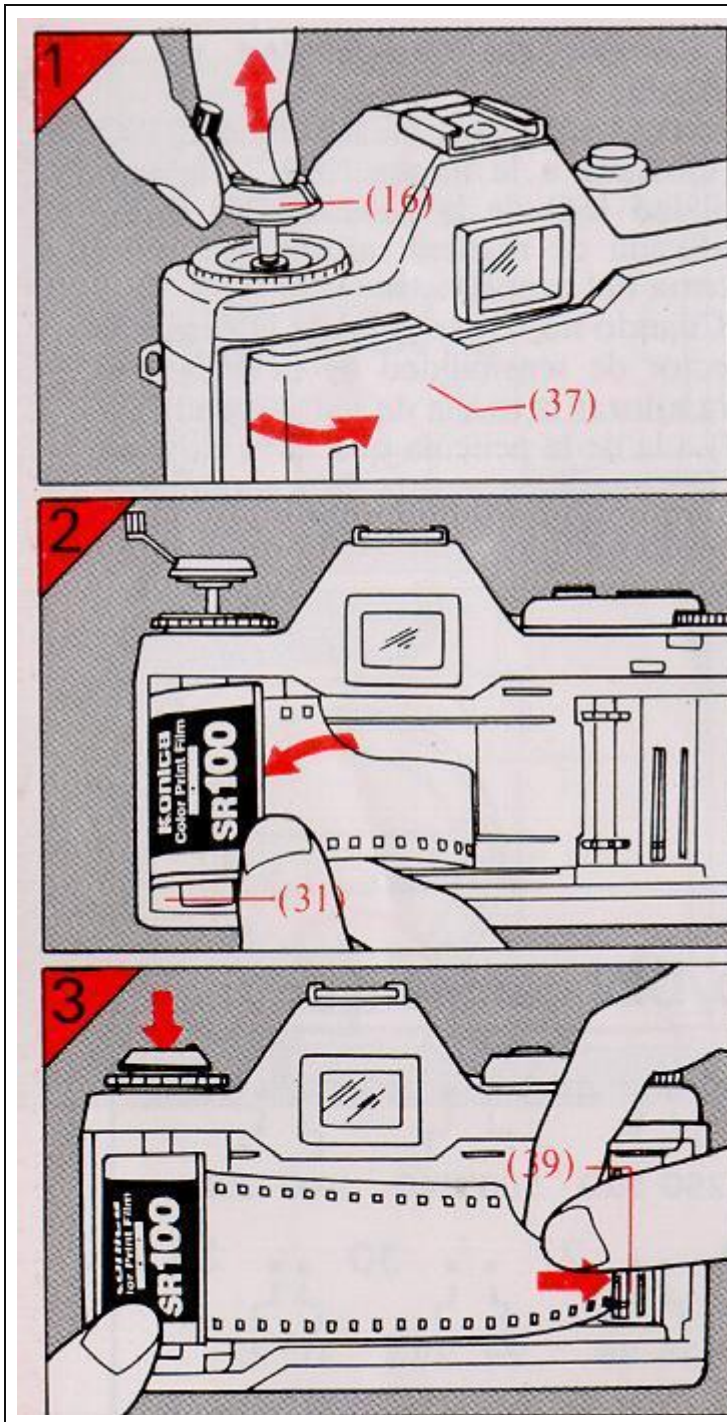

5. Loading film

- 1) Turn the power switch (2) "on." Pull the rewind knob (16) all the way out and the back cover (37) of the camera will open.
- 2) Place a roll film into the film cassette chamber (31), then push the rewind knob all the way back down.
- 3) Pull the tip of the film out a few centimeters until it reaches the film take-up spool (39). Then insert the tip into the slit in the take-up spool.
- 4) Turn the film advance lever (1) and make sure the holes in the edge of the film fit on the teeth of the sprocket (40). Now close the back cover tightly.
- 5) Raise the film rewind crank (15) and turn it slightly in the direction of the arrow to reduce slack of the film inside the magazine.

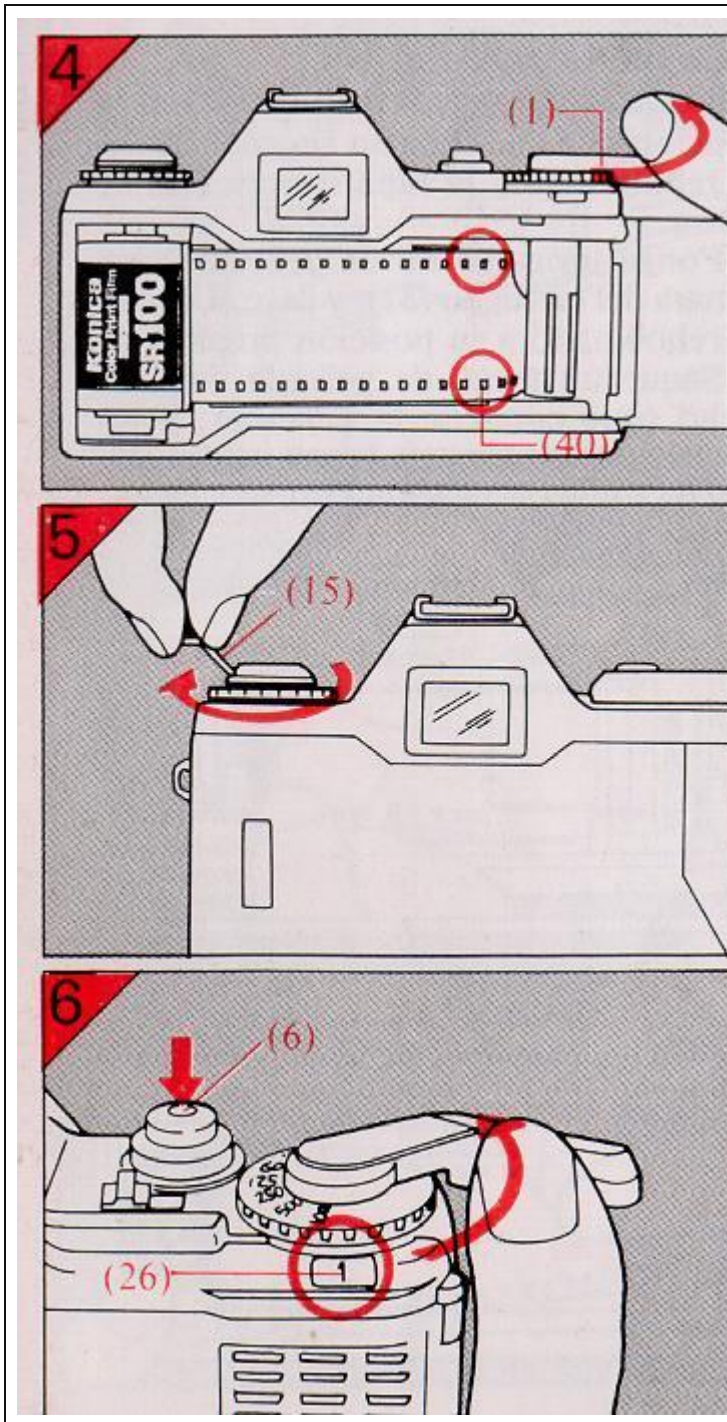

6) Turn the film advance lever (1) as far as it turns and press the shutter release button (6). Repeat until the number " 1 " appears in the frame counter (26).

*When the film is advancing properly, the film rewind knob will turn counterclockwise.

*Film should be loaded or unloaded in the shade or indoors, avoiding direct sunlight.

*The film check window is for use with DX type film, and lets the user check the kind of film, film speed, and number of frames exposed, while the film is in the camera.

6. Automatic exposure system (AE)

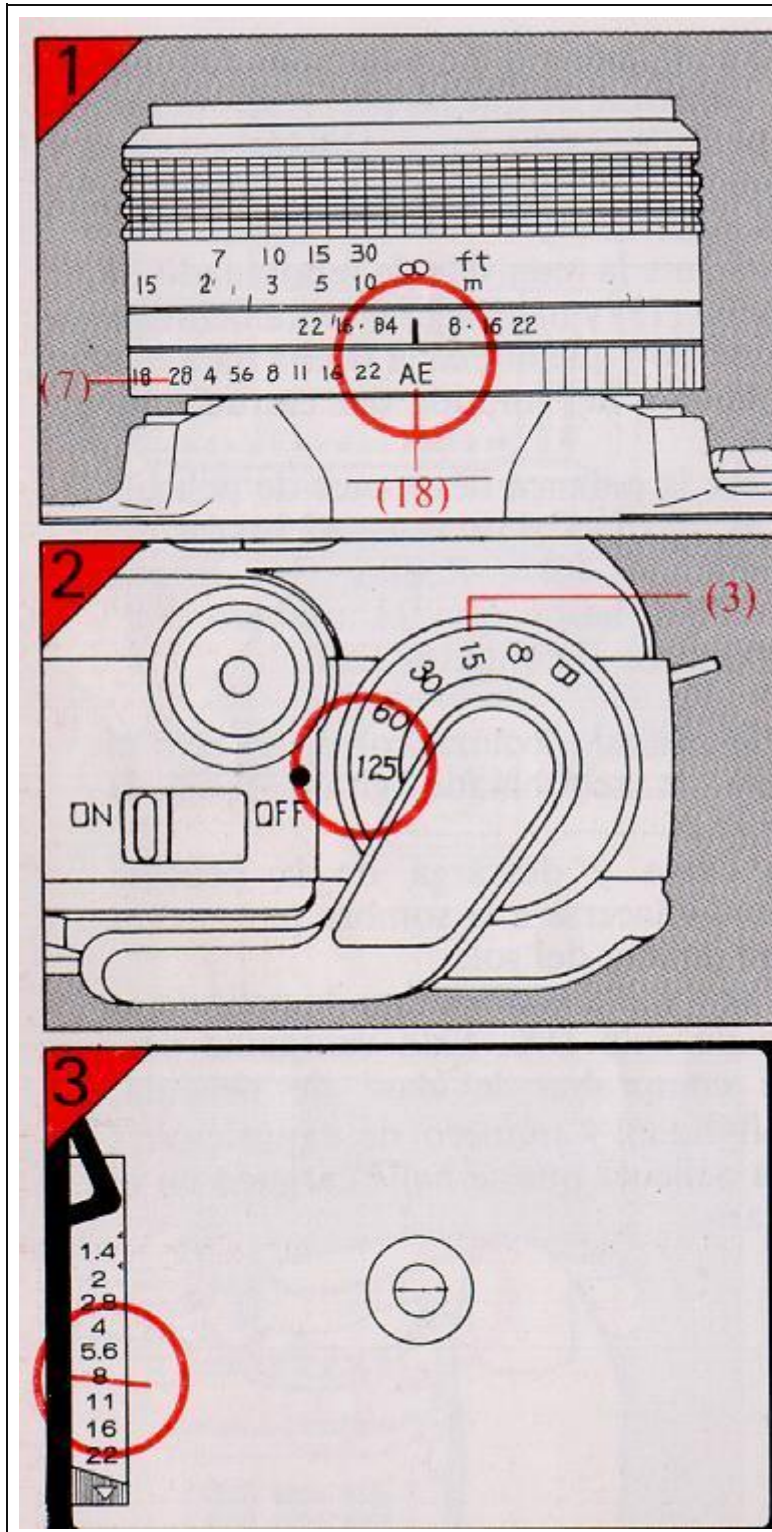

6. Automatic exposure system (AE)

1) Set the aperture ring (7) at the "AK" mark (18), and the aperture ring is then locked.

2) Turn the shutter speed dial (3) and set it at the desired speed. With ISO 100 film, for example, a typical shutter speed for shooting outdoors in clear weather is 1/125 or 1/250 sec, 1/30 or 1/60 for indoors.

*The "B" (bulb) setting does not allow AE shooting because the shutter remains open.

3) Look through the finder, compose the picture you want, and make sure the needle of the light meter does not indicate under or over exposure warning. Then just press the shutter to take a picture.

*For aperture-priority operation, look through the finder and turn the shutter speed dial (3) until the needle shows the desired aperture reading.

*Intermediate points between shutter speed scale (4) indicated on the shutter speed dial cannot be used.

*The Konica TC-X can be used without a battery, if desired, by setting both speed and aperture manually.

Focusing

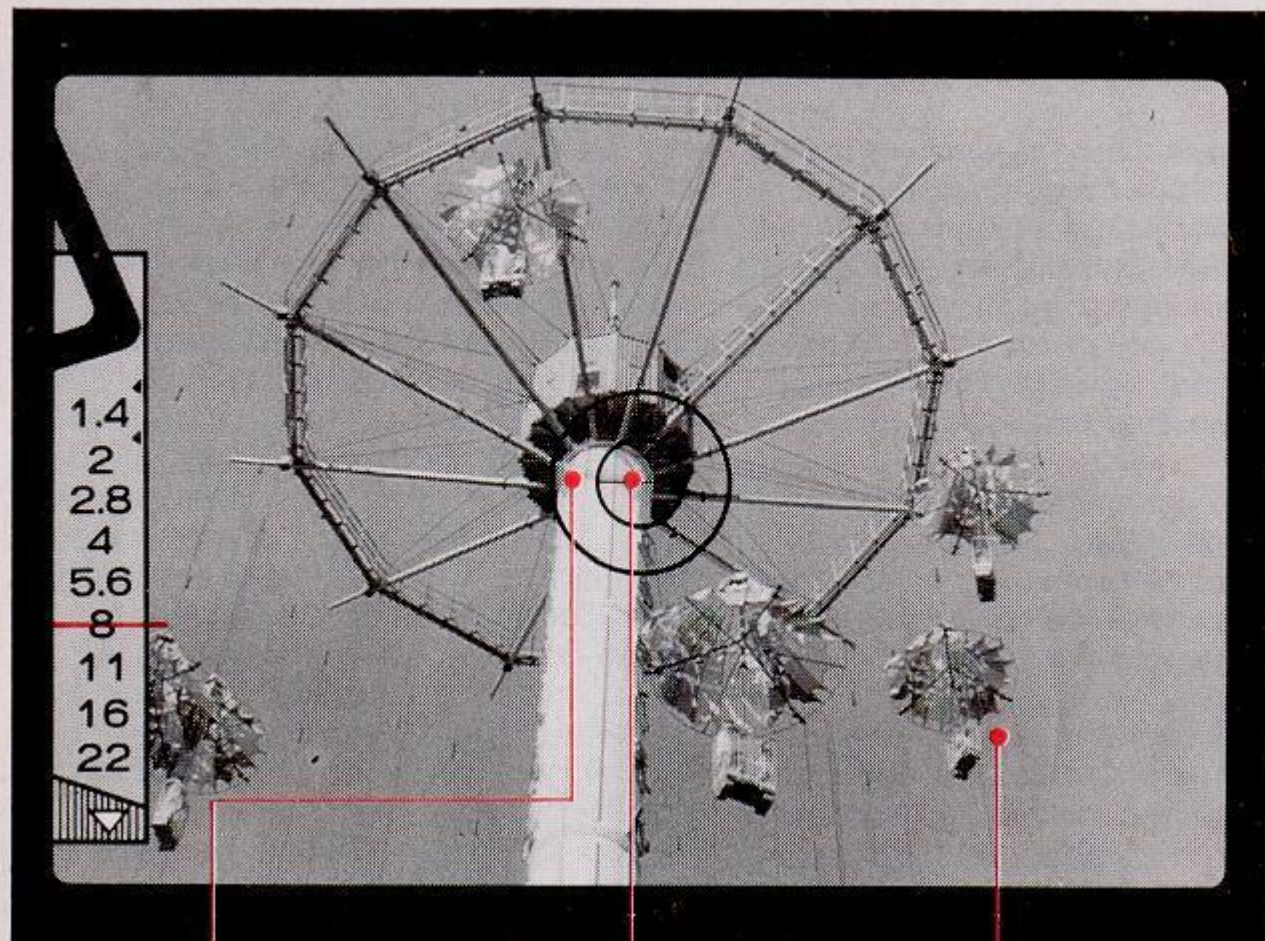

Microdiaprism

Split image

Matted plane

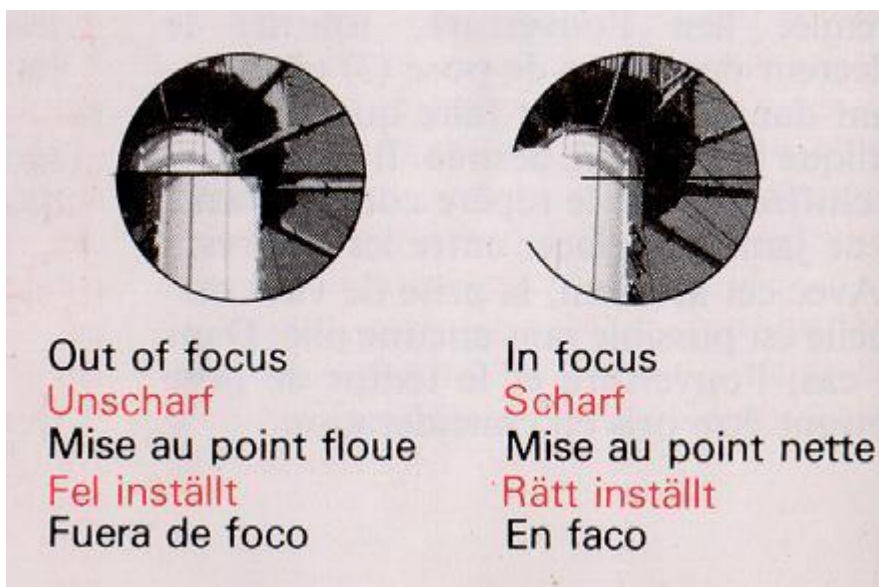

Out of focus

Unschärf

Mise au point floue

Fel inställt

Fuera de foco

In focus

Scharf

Mise au point nette

Rätt inställt

En faco

Focus at the center of the viewfinder
When focusing, point the camera directly at the main subject (area of the picture that is most important), to use the split image and microdiaprism for precise focusing.

Split image: The lens is focused when the upper and lower halves of the image in the center of the finder are aligned.

Microdiaprism: When the lens is focused, the image in this area of the finder stops flickering.

Matted plane: Use the matted screen surrounding the center of the finder to focus whenever the image at the center is not clear when using the camera with close-up attachment and telephoto lens, for example.

Checking the exposure

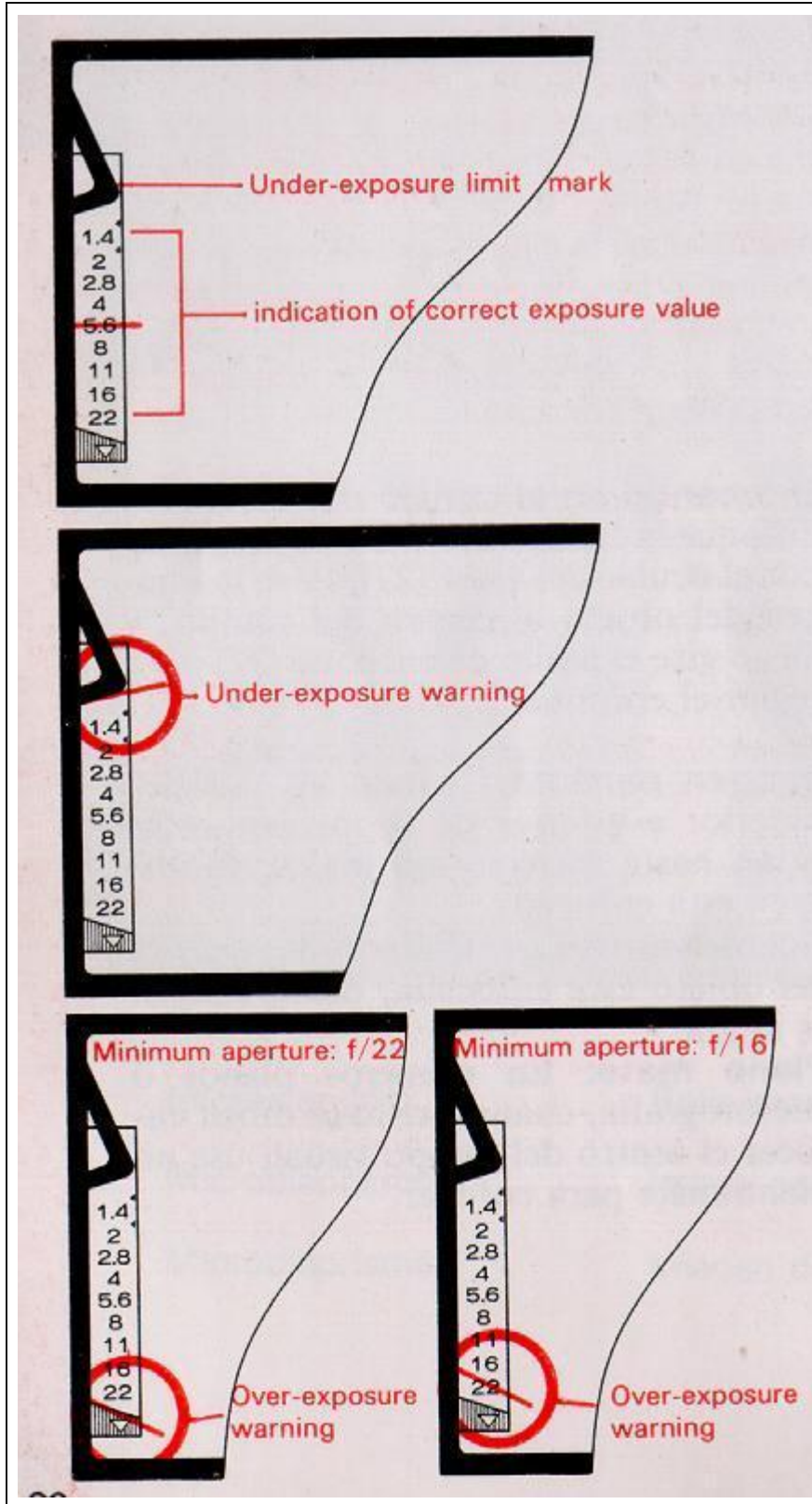

Checking the aperture:

The correct aperture setting for the shutter speed to which the camera is set will be shown by the needle in the finder. The camera will automatically select this aperture when the shutter is pressed.

* The proper exposure range varies according to the open-aperture f-number and the minimum stop-down f-number of the lens used.

Under-exposure warning:

If the meter needle moves to the top of the finder, there is not enough light for the shutter speed you have set. Choose a slower shutter speed to avoid an underexposure. (The under-exposure limit mark shifts according to the open aperture f-number of the lens used.)

Over-exposure warning:

If the meter needle moves down to the bottom of the finder or "22" a faster shutter speed may be needed to avoid an overexposure.

7. Unloading film

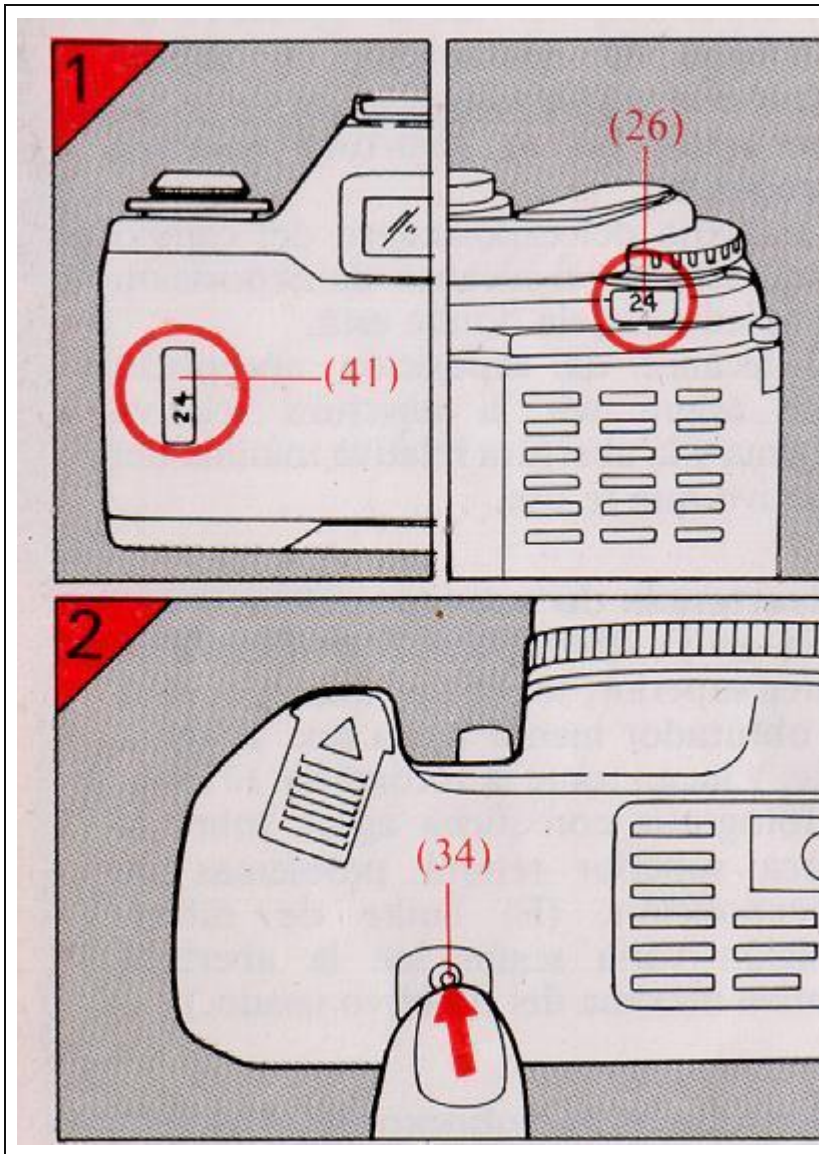

7. Unloading film

After shooting a whole roll of film, the film must be rewound before being removed from the camera.

1) With "DX" type film, the roll is finished when the number in the frame counter (26) is the same as the number in the film check window (41).

To rewind film:

2) Push the film rewind button (34) down.

8. Operation in manual mode

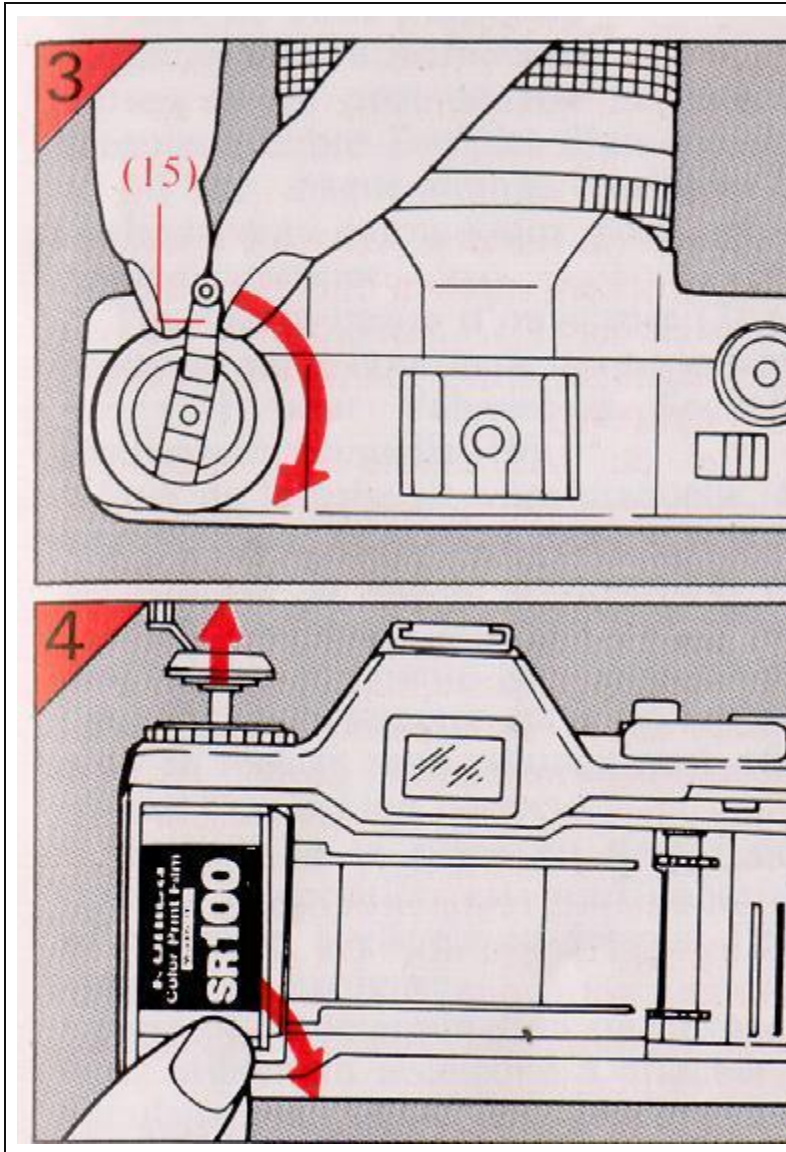

3) Flip up the film rewind crank (15) and turn it in the direction of the arrow.

4) When film is completely rewound, rewind crank will turn freely. Then open the back cover and remove the film magazine for processing.

8. Operation in manual mode Stopped-down metering:

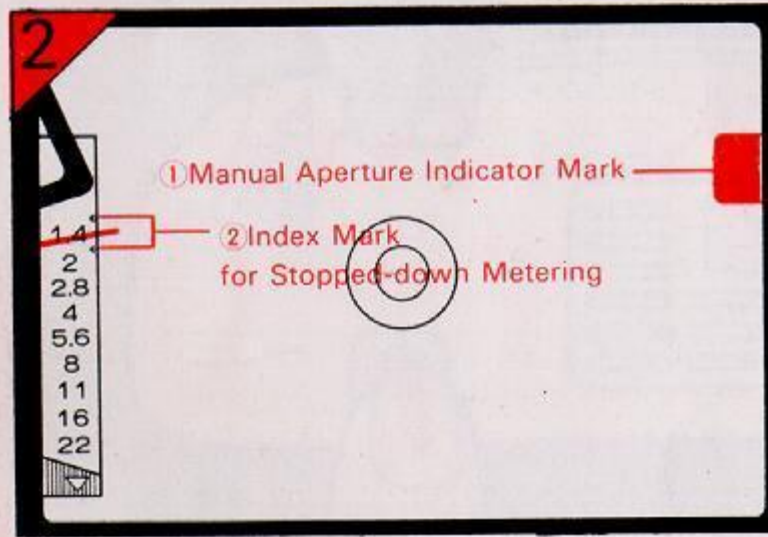
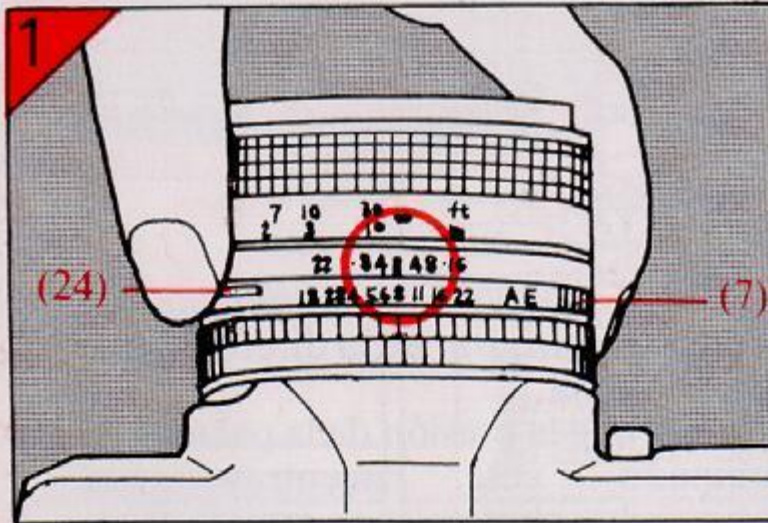

When an extension ring or bellows is used for close-up photography, or under other circumstances when the AE mechanism cannot be used, stopped down metering is recommended.

1) Press the AE release button (24) and turn the aperture ring (7) to set the aperture manually.

*A red warning mark will appear in the finder to show that the camera is set for manual aperture control.

2) Correct exposure can be obtained by turning the aperture ring or shutter speed dial (3), while looking through the finder, until the meter needle points to the stopped-down metering mark inside the finder.

'Pictures may be underexposed when the needle is above the index mark, and overexposed when the needle is below it.

*Exposure measurement in stopped down mode may be affected by light coming in through the camera eyepiece. It is a good idea to use an eye cup.

*Make sure the meter is exactly aligned with the stopped-down metering mark

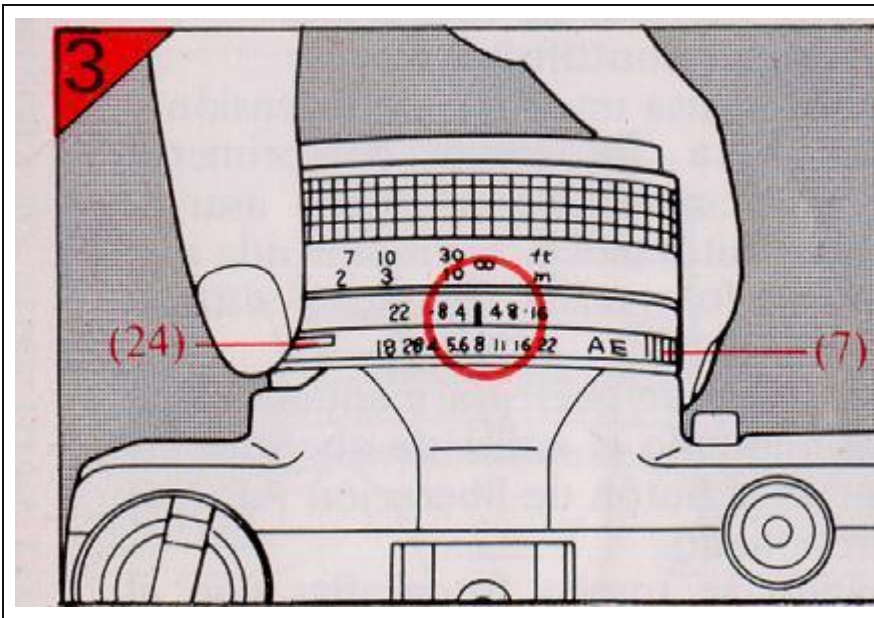

Light Metering at Full Lens Opening: Manual picture-taking may be carried out even with the Hexanon AR lens, Read the aperture value shown by the needle of the meter and set the manual aperture scale (19) according to the aperture value.

9. Using the self-timer

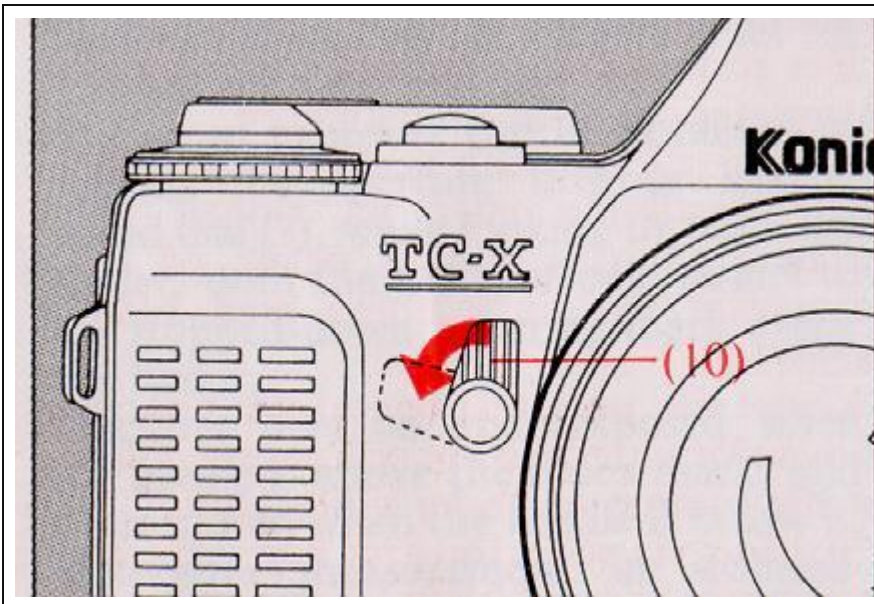

9. Using the self-timer

Turn the self-timer lever (10) counterclockwise (in the direction of the arrow) as far as it goes. Then press the shutter release button. The shutter will be released automatically in approx. 10 seconds

Exposure meter range -

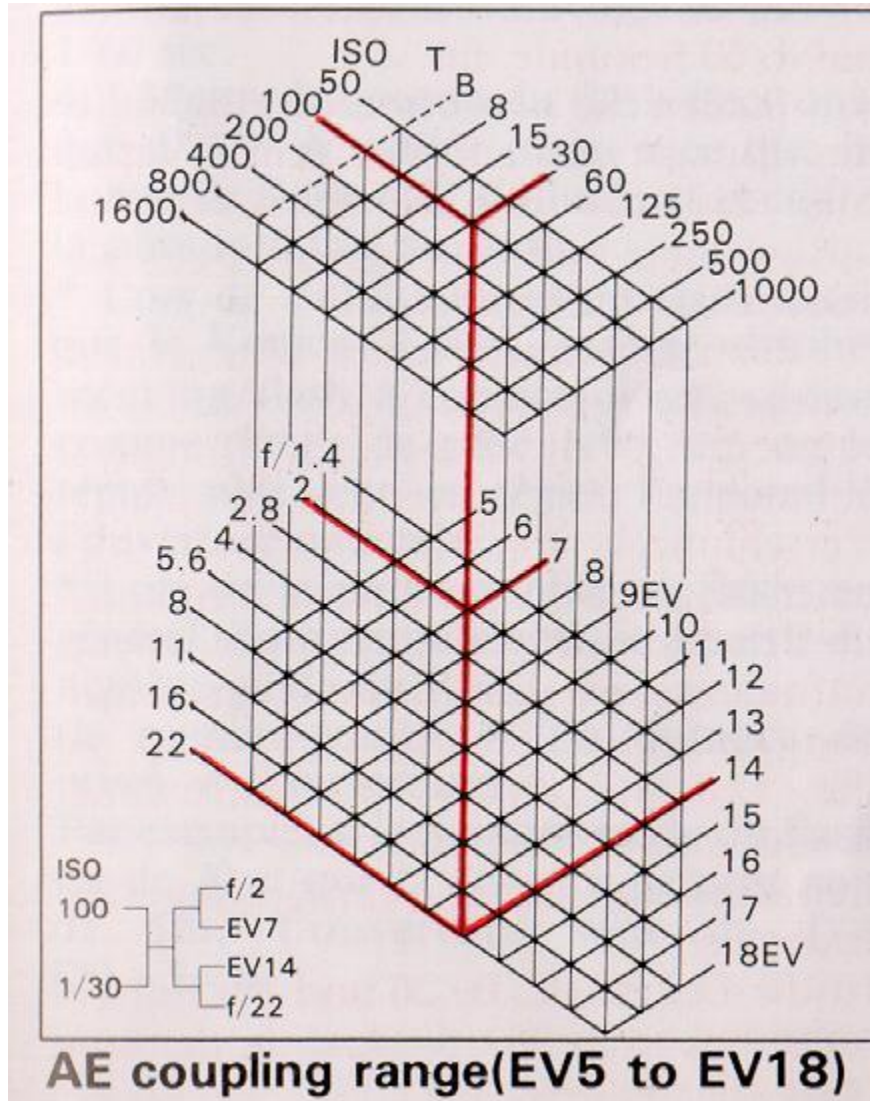



Depending on the ISO rating (film speed) of the film used, the effective range of the Konica TC-X's exposure meter is as shown in the following table:

[CLICK HERE FOR CHART WITH METER RANGE OF 50MM 1.4 LENS](#)

Exposure meter range with Hexanon AR 50mm f/1.4 lens (EV5 to EV18)

ISO \	$\frac{1}{8}$	$\frac{1}{15}$	$\frac{1}{30}$	$\frac{1}{60}$	$\frac{1}{125}$	$\frac{1}{250}$	$\frac{1}{500}$	$\frac{1}{1000}$
50	AE coupling without conditions	AE coupling without conditions	AE coupling without conditions	AE coupling without conditions	AE coupling without conditions	AE coupling without conditions	No AE coupling with conditions	No AE coupling with conditions
100	No AE coupling with conditions	AE coupling without conditions	AE coupling without conditions	AE coupling without conditions	AE coupling without conditions	AE coupling without conditions	AE coupling without conditions	No AE coupling with conditions
200	No AE coupling with conditions	No AE coupling with conditions	AE coupling without conditions	AE coupling without conditions	AE coupling without conditions	AE coupling without conditions	AE coupling without conditions	AE coupling without conditions
400	No AE coupling with conditions	No AE coupling with conditions	No AE coupling with conditions	AE coupling without conditions	AE coupling without conditions	AE coupling without conditions	AE coupling without conditions	AE coupling without conditions
800	No AE coupling with conditions	No AE coupling with conditions	No AE coupling with conditions	No AE coupling with conditions	AE coupling without conditions	AE coupling without conditions	AE coupling without conditions	AE coupling without conditions
1600	No AE coupling with conditions	No AE coupling with conditions	No AE coupling with conditions	No AE coupling with conditions	No AE coupling with conditions	No AE coupling with conditions	AE coupling without conditions	AE coupling without conditions

AE coupling without conditions 
No AE coupling with conditions 

10. Electronic flash photography

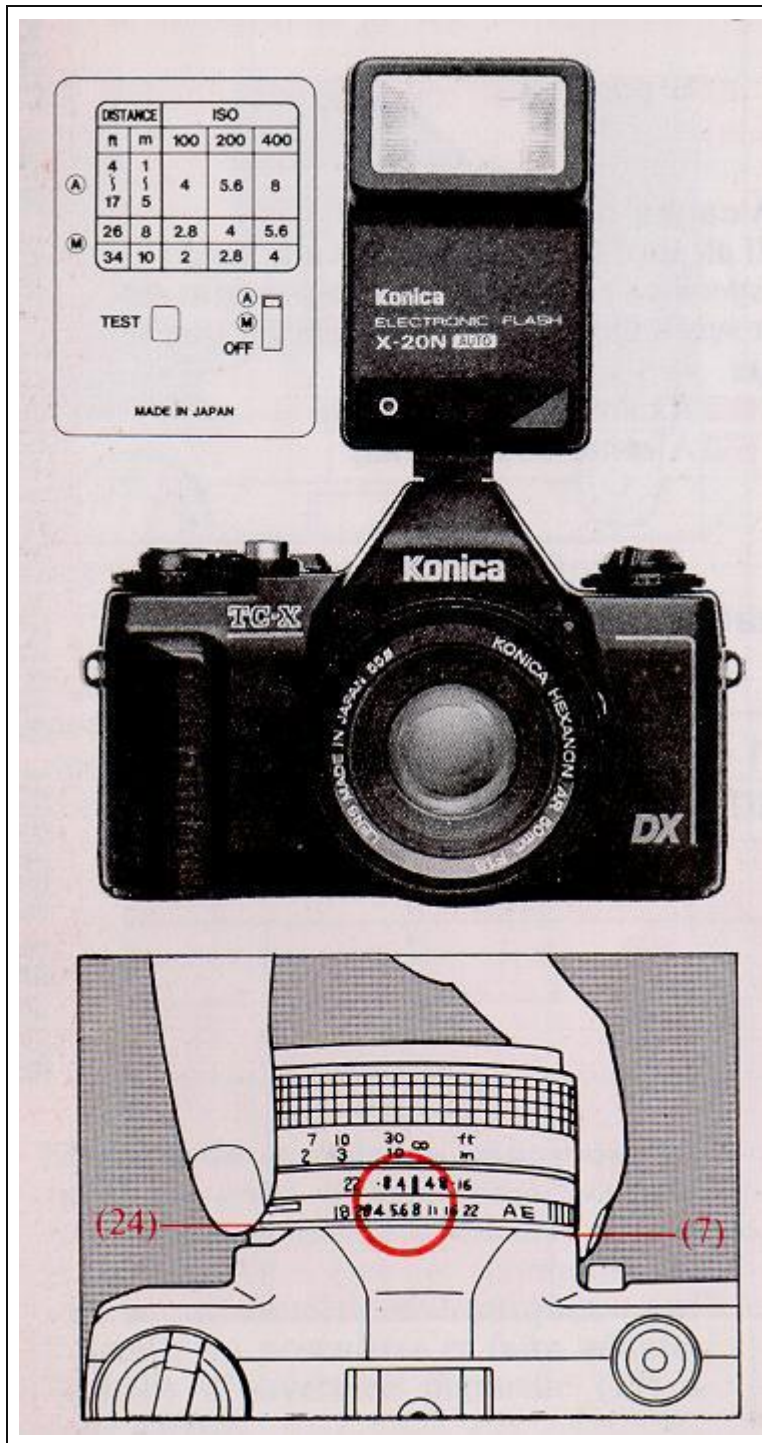

For taking pictures at indoors or at night, use of the Konica X-20N AUTO in the type of electronic auto flash is recommended.

- 1) Attach the Konica X-20N AUTO to the hot shoe (13) on the camera.
- 2) Switch from AE to manual aperture mode and set the aperture at f/4 (ISO 100) or at f/8 (ISO 400), according to the film speed.
- 3) Set the shutter speed to 1/60 sec.
- 4) Set the power switch of the electronic flash at "A" and wait until the Flash Ready Light goes on for the flash photography.

* Ordinary electronic flash units of the hot-shoe type may also be used with the Konica TC-X with shutter speed set at 1/60 sec or slower, and manual aperture setting.

Correct aperture value can be calculated from the guide number (GN) of the flash unit. Divide the GN by the distance, in meters, from camera to subject to get correct aperture ("f" number). For example, if the flash unit's GN is 20, and distance from camera to subject is 5 meters, f/4 will be the correct aperture value. ($20 / 5 = 4$)

Exposure compensation



Bright subject, dark background

If the subject in the frame is brightly lit (ea. by direct sunlight) and the background is dark, the subject will be overexposed in normal AE photography.

To prevent this, move up close to the subject and press the shutter half way down to lock the AE mechanism. Then move back to frame and shoot the picture you want.

Exposure compensation

Use the AE Lock mechanism to control exposure in special lighting situations.

If the subject is in front of a bright background or light source, the foreground will be underexposed. To prevent this, aim the camera towards the ground (widening the aperture by 1 or 2 steps) and press the shutter release halfway down.

The camera will take a reading for the foreground and will lock at that reading as long as the shutter is held down half way. Then aim at camera at the subject and press the shutter all the way down to get a correctly exposed picture.

Using depth of field

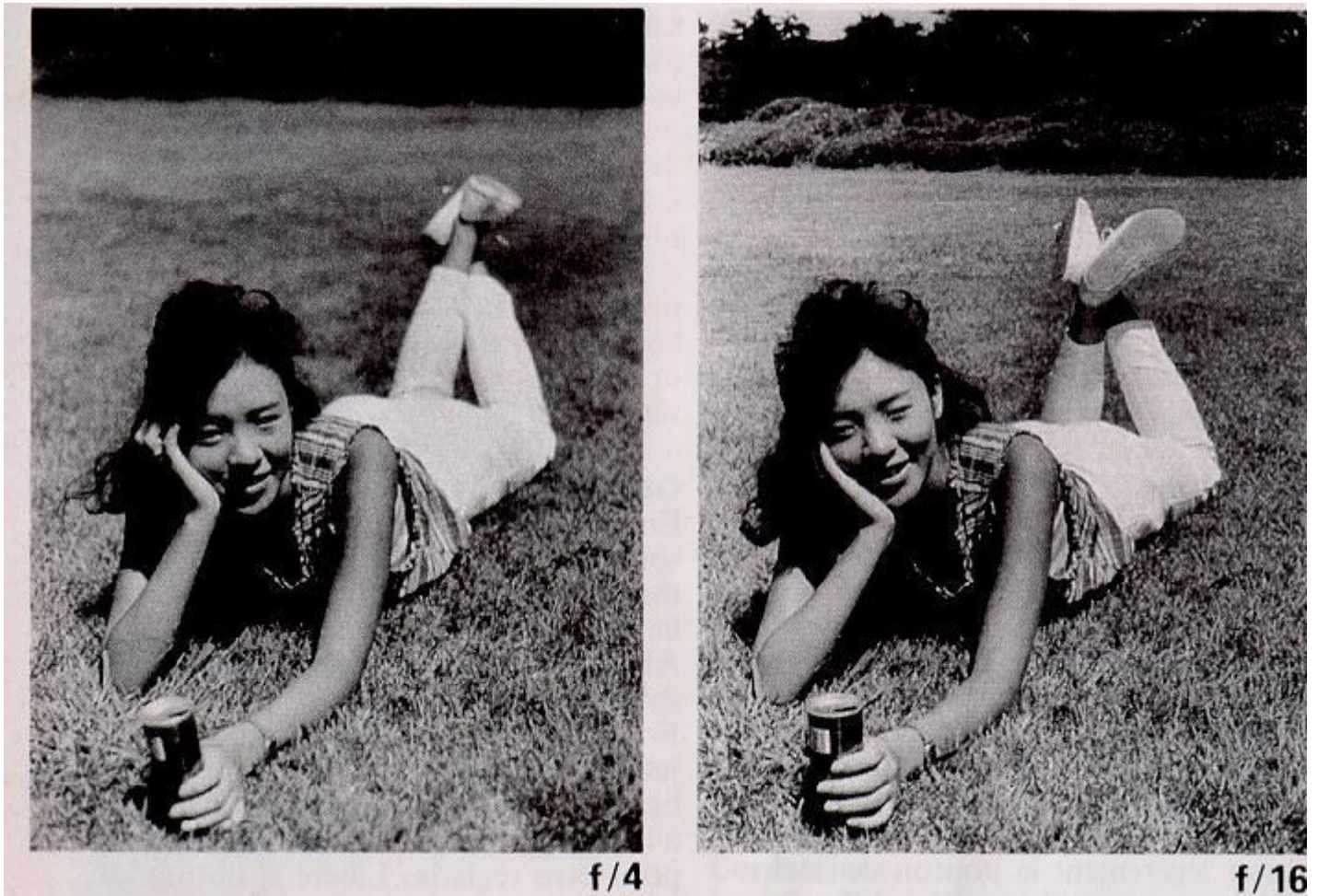

Using depth of field

Depth of field is the range in front of and behind the point on which the lens is actually focused which also appears in sharp focus in the photograph.

It has the following features:

- 1) The smaller the lens aperture ("F" stop) the greater the depth of field.
- 2) Wide angle lenses have greater depth
- 3) Depth of field behind the point of actual focus (away from the camera) is greater than depth of field in front (towards the camera). It is possible to render the background and foreground in focus (a great depth of field), by using a small aperture, or to blur the background whilst keeping the subject in focus, using a larger aperture.

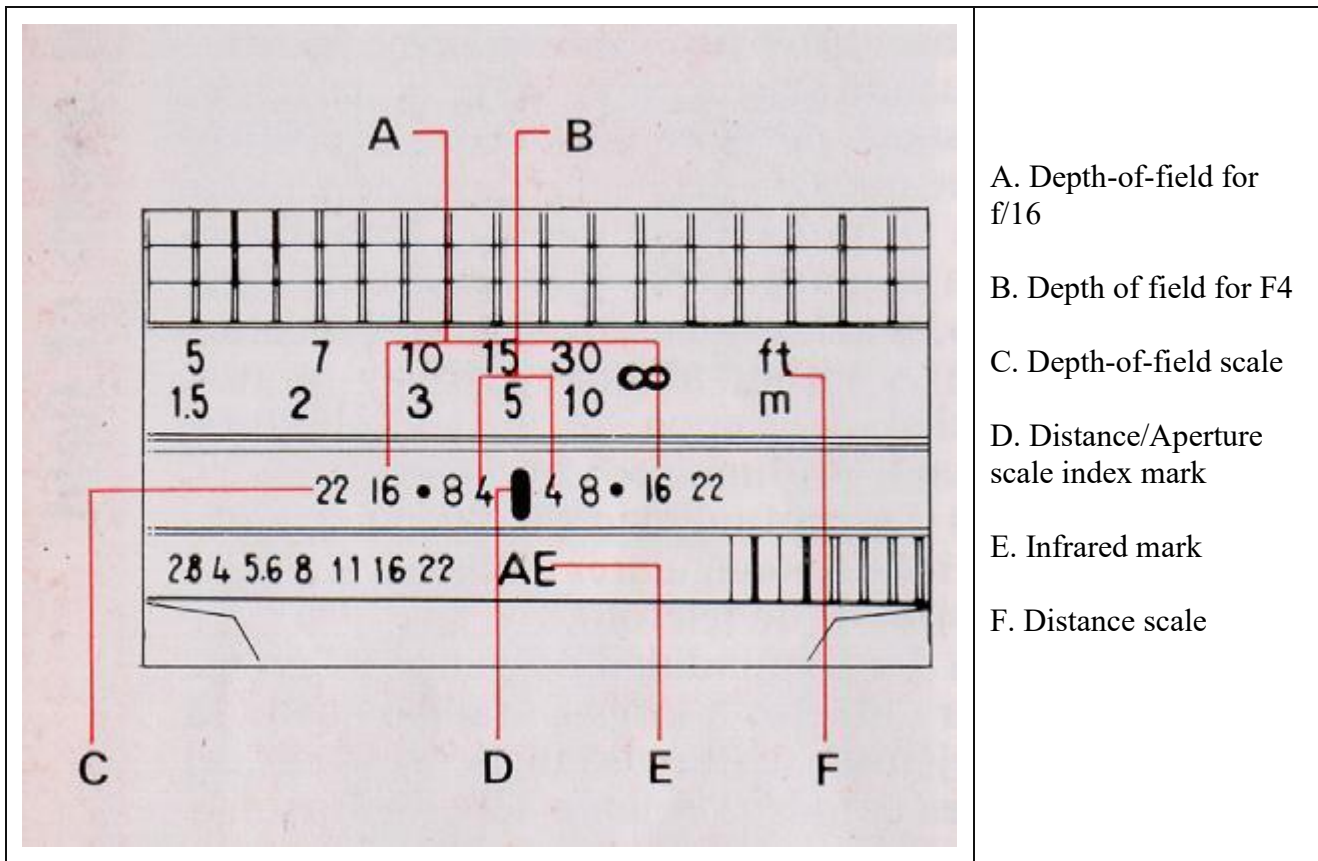

Depth-of-Field Table (50mm f/1.8) Permissible aberrated circle diameter 3/100mm

Aperture	1.8ft	2.62ft	3.28ft	6.56ft	16.4ft	∞
f/1.8	1.80~1.84	2.59~2.66	3.22~3.35	6.33~6.82	14.93~18.21	160.50~∞
f/2.8	1.77~1.84	2.59~2.69	3.22~3.38	6.20~6.96	14.24~19.39	103.28~∞
f/4	1.77~1.84	2.56~2.69	3.18~3.41	6.07~7.15	13.48~21.03	72.41~∞
f/5.6	1.77~1.84	2.53~2.72	3.12~3.48	5.91~7.41	12.57~23.72	51.80~∞
f/8	1.74~1.87	2.49~2.79	3.05~3.54	5.64~7.87	11.45~29.36	36.35~∞
f/11	1.74~1.90	2.43~2.85	2.99~3.64	5.38~8.50	10.36~41.93	26.54~∞
f/16	1.71~1.94	2.37~2.95	2.85~3.87	4.95~9.88	8.83~149.93	18.34~∞
f/22	1.67~2.00	2.30~3.12	2.76~4.13	4.56~12.24	7.55~∞	13.42~∞

Aperture	0.55m	0.8m	1.0m	2.0m	5.0m	∞
f/1.8	0.55~0.56	0.79~0.81	0.98~1.02	1.93~2.08	4.55~5.55	48.92~ ∞
f/2.8	0.54~0.56	0.79~0.82	0.98~1.03	1.89~2.12	4.34~5.91	31.48~ ∞
f/4	0.54~0.56	0.78~0.82	0.97~1.04	1.85~2.18	4.11~6.41	22.07~ ∞
f/5.6	0.54~0.56	0.77~0.83	0.95~1.06	1.80~2.26	3.83~7.23	15.79~ ∞
f/8	0.53~0.57	0.76~0.85	0.93~1.08	1.72~2.40	3.49~8.95	11.08~ ∞
f/11	0.53~0.58	0.74~0.87	0.91~1.11	1.64~2.59	3.14~12.78	8.09~ ∞
f/16	0.52~0.59	0.72~0.90	0.87~1.18	1.51~3.01	2.69~45.70	5.59~ ∞
f/22	0.51~0.61	0.70~0.95	0.84~1.26	1.39~3.37	2.30~ ∞	4.09~ ∞

Konica Lenses available



Specifications of lenses available

	Focal Length	Apertures Max.-Min.	Construction Elements/Group	Angle of View	Min. Focus from Film Plane	Length	Max. Diameter	Weight	Filter	Lens Hood
Fish-Eye	15mm UC	f/2.8-f/16	10/7	180°	0.15m (6.0')	60mm(2.4')	70mm(2.8')	395g(13.9oz.)	Built-in	Built-in
Extreme Wide	21mm	f/2.8-f/22	9/8	92°	0.2m (8.0')	39mm(1.5')	63mm(2.5')	215g (7.6oz.)	55mm	Incl.(KH1)
	24mm	f/2.8-f/22	8/8	84°	0.25m (10.0')	36mm(1.4')	63mm(2.5')	205g (7.2oz.)	55mm	Avail.(KH2)
Wide	28mm UC	f/1.8-f/16	8/8	75°	0.18m (7.0')	63mm(2.5')	66mm(2.6')	380g(13.4oz.)	55mm	Incl.(KH2)
	28mm	f/3.5-f/22	5/5	75°	0.3m (12.0')	36mm(1.4')	63mm(2.5')	175g (6.2oz.)	55mm	Incl.(KH2)
	35mm	f/2.0-f/16	9/7	63°	0.3m (12.0')	57mm(2.2')	65mm(2.6')	320g(11.3oz.)	55mm	Incl.
	35mm	f/2.8-f/22	5/5	63°	0.3m (12.0')	38mm(1.5')	63mm(2.5')	200g (7.1oz.)	55mm	Avail.(KH3)
Standard	50mm	f/1.4-f/22	7/6	46°	0.45m (18.0')	45mm(1.8')	63mm(2.5')	265g (9.3oz.)	55mm	Avail.(KH3)
	50mm	f/1.8-f/22	6/5	46°	0.55m (22.0')	33mm(1.3')	63mm(2.5')	175g (6.2oz.)	55mm	Avail.(KH3)
	57mm	f/1.2-f/16	7/6	42°	0.45m (18.0')	50mm(2.0')	72mm(2.8')	460g(16.2oz.)	62mm	Avail
Telephoto	85mm	f/1.8-f/16	6/5	28.5°	1m (40.0')	67mm(2.6')	65mm(2.6')	390g(13.8oz.)	55mm	Incl.
	100mm	f/2.8-f/16	5/4	24°	1m (47.6')	62mm(2.4')	63mm(2.5')	290g(10.2oz.)	55mm	Incl.
	135mm	f/2.5-f/16	4/4	18°	1.2m (59.0')	96mm(3.8')	69mm(2.7')	650g(22.9oz.)	62mm	Built-in
	135mm	f/3.5-f/22	4/4	18°	1.5m (8.2')	82mm(3.3')	63mm(2.5')	315g(11.1oz.)	55mm	Built-in
	200mm	f/4.0-f/22	5/5	12°	2.5m (13.0')	121mm(4.8')	65mm(2.6')	515g(18.2oz.)	55mm	Built-in
	300mm	f/4.5-f/16	8/5	8°	4m (13.0')	168mm(6.7')	80mm(3.2')	965g(34.0oz.)	72mm	Built-in
	400mm UC	f/5.6-f/45	9/5	6°	4m (20.0')	217mm(8.6')	83mm(3.3')	1,600g(3.51bs.)	77mm	Built-in
Zoom	28-135mm	f/4(4.6)-f/22	18/12	76-18°	0.5m (31.5')	114mm(4.4')	74mm(2.9')	800g(28.2oz.)	67mm	Incl.
	35-70mm	f/4.0-f/22	8/7	63-35°	0.8m (31.5')	69.5mm(2.7')	67.5mm(2.7')	390g(13.8oz.)	55mm	Incl.
	70-150mm	f/4.0-f/22	15/12	34-16°	0.8m (74.8')	102mm(4.0')	67mm(2.6')	500g(17.6oz.)	55mm	Built-in
	80-200mm	f/4.0-f/22	12/9	30-12°	1.9m (10.0')	138mm(5.5')	65mm(2.6')	590g(20.9oz.)	55mm	Incl.
Macro	55mm	f/3.5-f/22	4/3	43°	0.25m (10.0')	60mm(2.4')	64mm(2.5')	290g(10.2oz.)	55mm	Avail(KH3)
	105mm	f/4.0-f/22	5/3	23°	★	47mm(1.9')	63mm(2.5')	230g (8.1oz.)	55mm	Avail.(KH3)
Other	Teleconverter AR2X	—	6/5	—	—	43.5mm(1.7')	63mm(2.5')	230g (8.1oz.)	—	—

★ Depending on bellows extension length.

Chart of accessories available for Konica

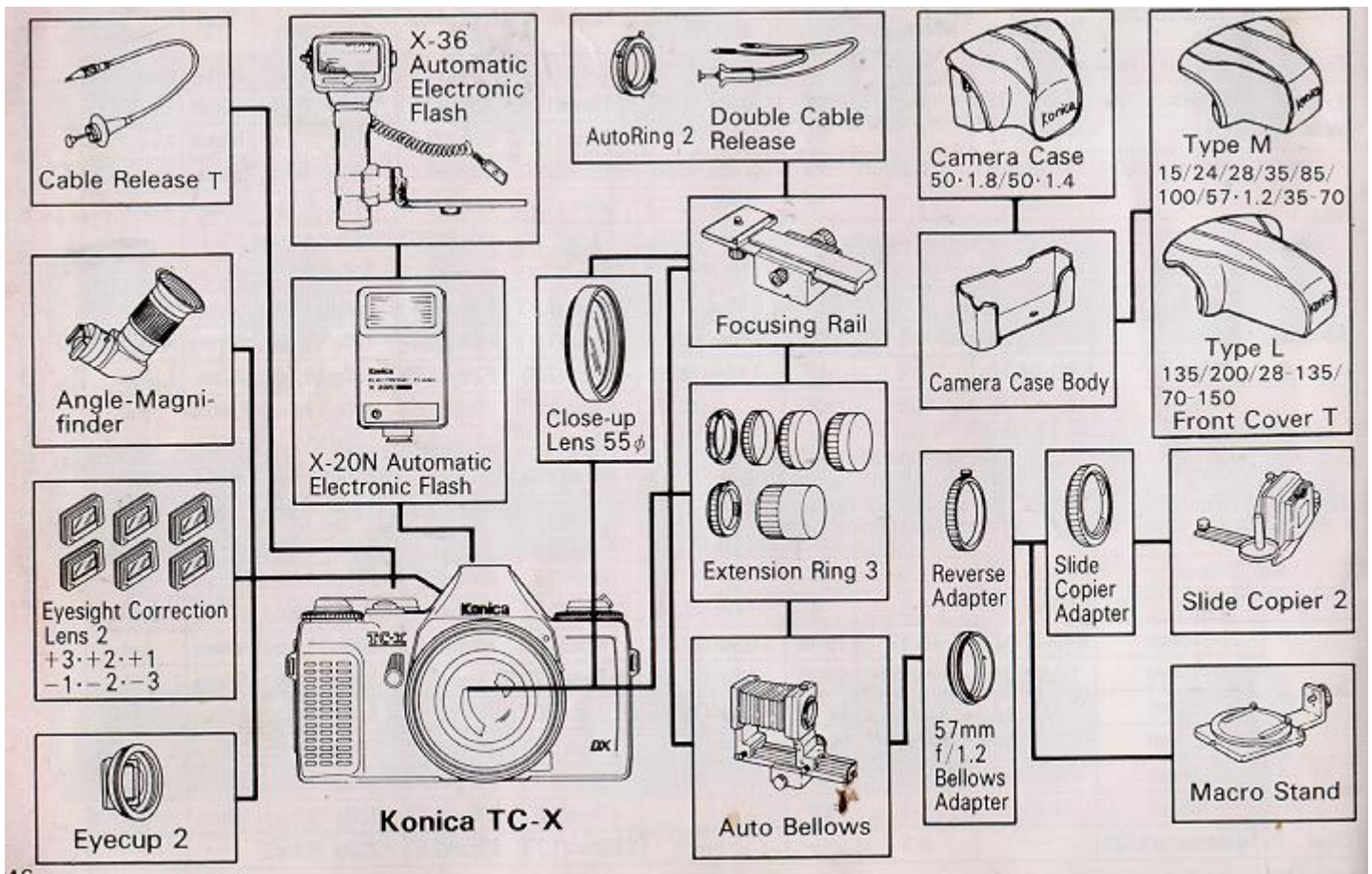

Precautions for use

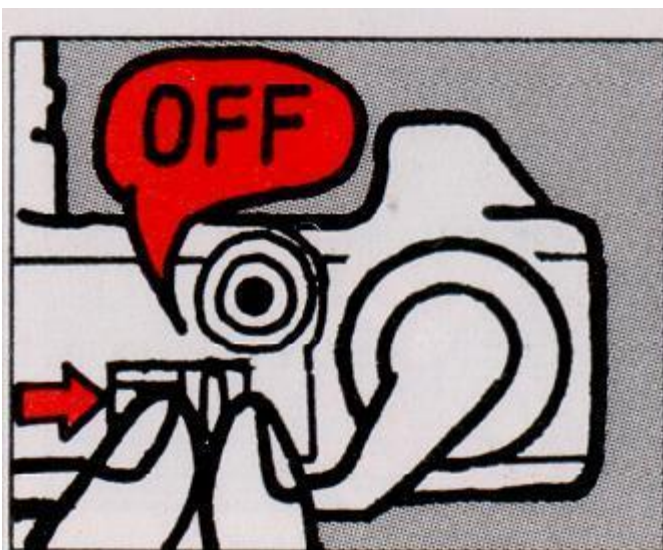

- If you are not using your camera for some time, remove battery and keep the camera in a place free of dust and humidity. Do not leave film in the camera for a long time.



· Turn off the power switch when not using the camera.

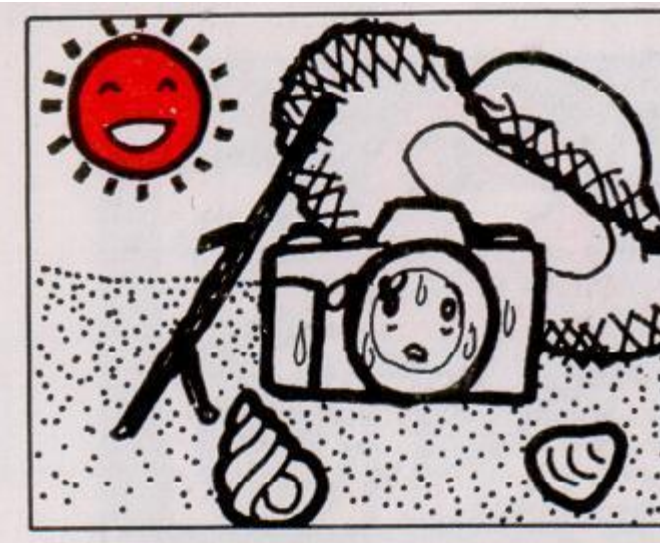

· Do not keep the camera in or around new wooden or plastic furniture, since the chemicals used in such furniture are harmful to both cameras and film.

· Do not leave the camera in direct sunlight in the summer, or in the trunk of a car in the sun. Too much heat or humidity may hurt both battery and camera, as well as film.



· At temperatures of less than 0°C (32°F); battery voltage will drop and meter performance will be affected. When using camera in extreme cold, replace with fresh battery or warm the battery in pocket or hand before use.



· Clean lens and mirror with blower brush when necessary.

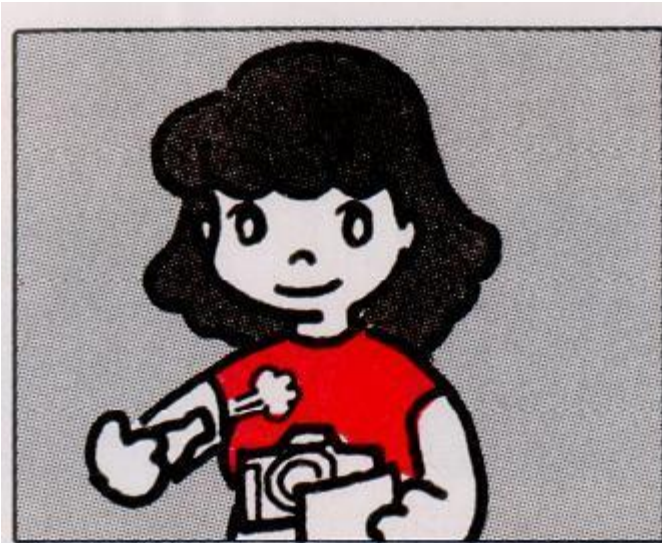

· Attaching a UV or skylight filter to your lens is a good way to protect lens from scratches and dirt.



· If your camera does not work, take it with your warranty and purchase receipt to the shop where you purchased it or to your nearest Konica Service Station.