

Ricoh XR-20sp

**(Never put a Ricoh program lens
on a Pentax AF or Digital body,
there is a pin on lens that will
get stuck on the body.**

**This includes lenses by Sears made
as PK/R, for both film bodies)**

This camera manual library is for reference
and historical purposes, all rights reserved.

This page is © 2001 by M. Butkus, NJ.
This page may not be sold or distributed without
the expressed permission of the producer
On-line camera manual library

If you find this manual useful, how about a donation of \$3 to:

M. Butkus, 29 Lake Ave., High Bridge, NJ 08829

**This will help me to continue to host this site,
buy new manuals, and pay their shipping costs.
It'll make you feel better, won't it?**

**If you use Pay Pal, use the link below.
Use the above address for a check, M.O. or cash.**

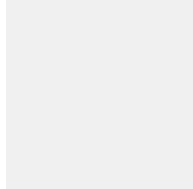

www.PayPal.me/butkus

Venmo @mike-butkus-camera

This page copyright by **mike@butkus.org**

[Back to my Camera manual web site](#)



- | | |
|---|--|
| <ol style="list-style-type: none">1. Attaching the finder cap and strap2. Mount the lens3. Set lens at "P"4. Insert batteries5. Check battery condition6. Insert film7. Set the film speed8. Indications in viewfinder (very enlarged for detail)9. Hold you camera properly10. Program AE photography11. Speed program AE photography (fast action shutter will not go below 1/250)12. Aperture-priority AE photography (aperture will vary)13. Manual photography (both shutter and aperture need adjustments)14. Focusing15. Rewind the film | <ol style="list-style-type: none">17. Programmed flash photography18. With Ricoh flash other then 300p or smaller programmed unit19. With non-dedicated flash20. Exposure compensation (temporarily adjust ASA to higher or lower speed)21. AE lock (temporarily lock Auto Exposure setting for special lighting)22. Depth of field23. Bulb setting24. Viewfinder lighting25. Power on-off switch26. Memo holder27. Infrared mark28. Accessories29. Care of batteries30. Storage of camera31. Specifications |
|---|--|

16. Self-timer photography (get in the photo or slow shutter speed firing)

NOMENCLATURE

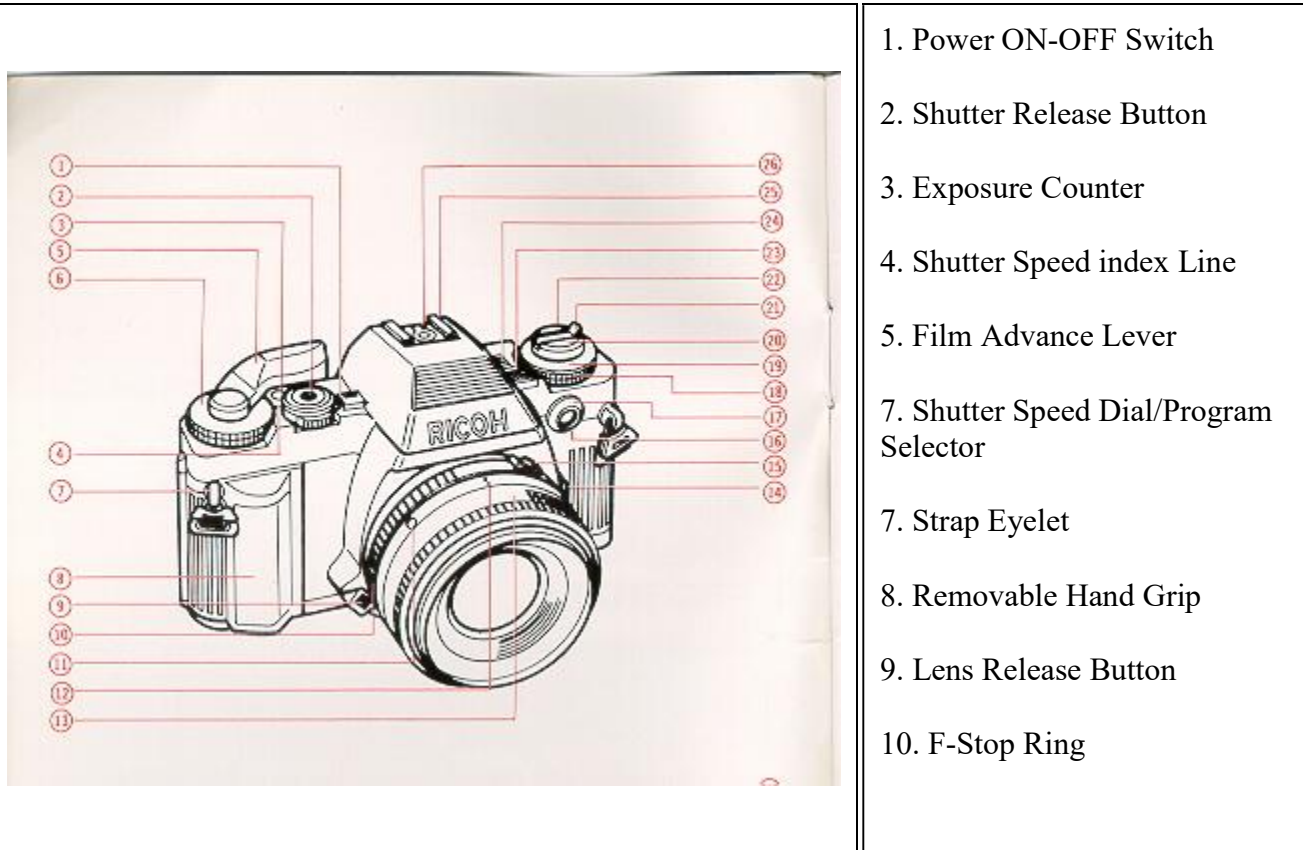

1. Power ON-OFF Switch
2. Shutter Release Button
3. Exposure Counter
4. Shutter Speed index Line
5. Film Advance Lever
7. Shutter Speed Dial/Program Selector
7. Strap Eyelet
8. Removable Hand Grip
9. Lens Release Button
10. F-Stop Ring

11. Lens Locator Mounting knob
12. Depth of Field Scale
13. Focusing Ring
14. AE Lock/illuminator Button
15. P Lock Button
16. Self Timer Button
17. Self Timer Monitor
18. Film Speed Dial

19. Exposure Compensation Dial
20. Film Rewind Knob/Back Cover Lock Release
21. Film Rewind Crank
22. Film Speed Index Line
23. Exposure Compensation Line
24. Illuminating Window
25. Hot Shoe
26. Flash Control Contact

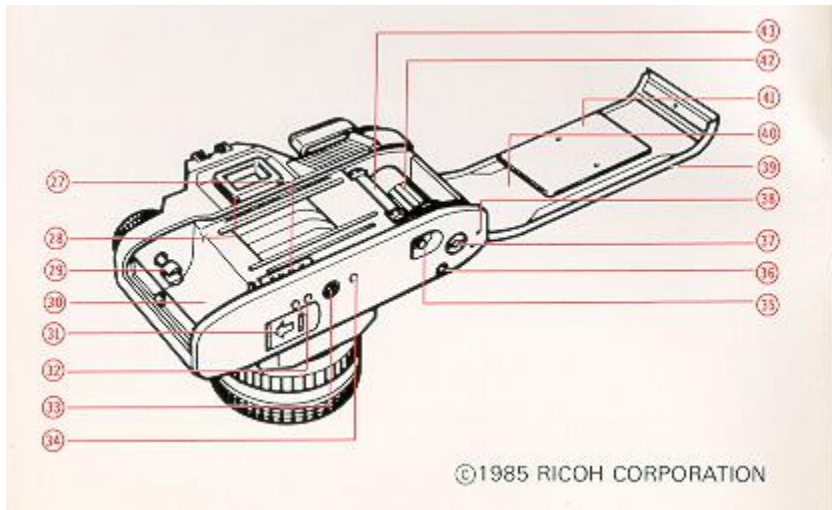

- 27. Data Back Contacts
- 28. Viewfinder Eyepiece
- 29. Film Rewind Shaft
- 30. Film Chamber
- 31. Battery Compartment Cover
- 32. Motor Drive Contacts
- 33. Tripod Socket
- 34. Winder Contact

- 35. Film Rewind Release Button
- 36. Hand Grip Release Button
- 37. Winder/Motor Drive Coupler
- 38. Winder Positioning Hole
- 39. Memo Holder/Program Curve Display

- 40. Back Cover
- 41. Film Pressure Plate
- 42. Film Take-up Spool
- 43. Sprocket

ATTACHING THE VIEWFINDER CAP AND STRAP

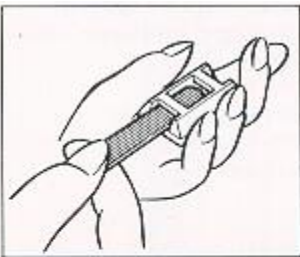

Fig. 1

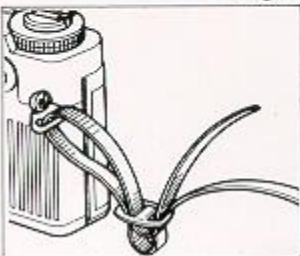
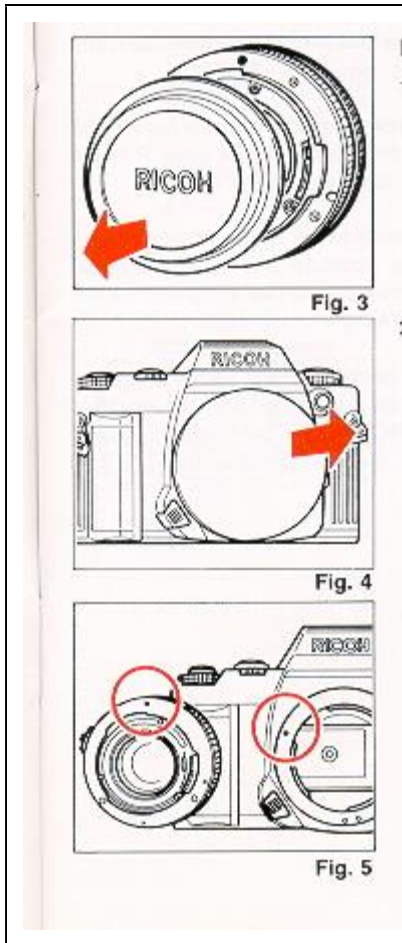

Fig. 2

1. Slip the Viewfinder Cap on to the strap. (Fig. 1)
2. Run the strap through the strap lug until the strap protrudes about 3 cm from the lug. Then adjust the strap length as desired. (Fig. 2)

MOUNT THE LENS



1. Pull the back lens cap to remove it from the lens. (Fig. 3)

2. Pull off the body cap (Fig. 4)

3. Align the red dot on the camera with the red dot on the lens and mount the lens on the camera. (Fig. 5)

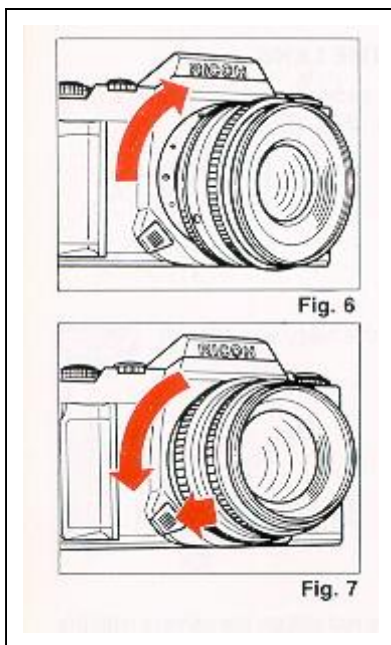

4. Turn the lens in the arrow direction until it clicks into place. (Fig. 8)

* To remove the lens, turn the lens in the arrow direction with the Lens Release Button depressed. (Fig. 7)

* The conventional K mount lens can be used as aperture-priority and manual but cannot be used for programmed AE photography.

* Proper performance of camera may not always be guaranteed with lenses other than RICOH. For best results, use a RICOH original equipment lens.

SET LENS AT "P" POSITION

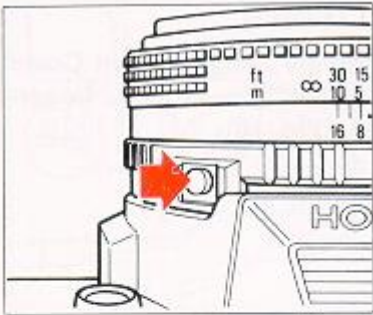

Fig. 8

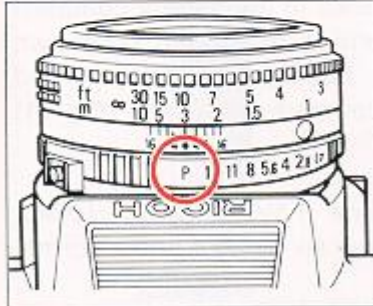

Fig. 9

1. Turn the F-Stop Ring while P Lock Button is pressed. (Fig. 8)

2. Set it to the locking "P" position as shown for programmed automatic exposure photography. (Fig. 9)

* To unlock "P", turn the F-Stop ring while P Lock Button is depressed.

INSERT BATTERIES

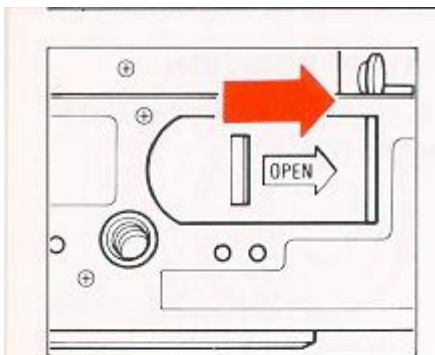

Fig. 10

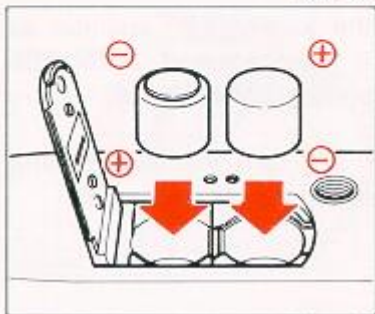

Fig. 11

(Webmaster - Note the bumps on the batteries. They are the negative contacts. The image shows the CR-1/3N type. If you purchase the 4 smaller batteries each side will have two batteries. The bottom left will have both batteries with their bumps up, on the right side the two batteries will have their bumps facing down. Note though, where the tripod screw is on the image. Use a pen eraser and clean the door contacts and bottom battery contacts of any dirt, carefully with a turning motion if needed.)

1. Slide the Battery Compartment Cover in the arrow direction with your fingernail to open. (Fig. 10)

2. Place batteries in the battery compartment according to (+) and (-) shown inside the battery compartment and close the compartment cover. (Fig. 11)

Batteries for use

Four alkaline 1.5V batteries (LR44): Lasting about six months under normal use.

Four silver oxide 1.55V batteries (SR44): Lasting about one year under normal use.

Two lithium 3V batteries (CR-1/3N): Lasting about one year under normal use.

* Also refer to "CARE OF BATTERIES."

CHECK CONDITION OF BATTERIES

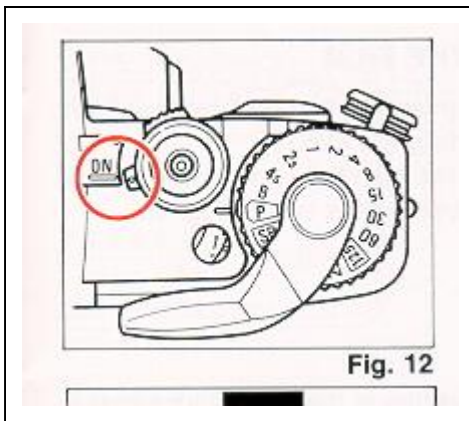

1. Turn the Power ON-OFF Switch ON. (Fig. 12)
2. Batteries are in good condition, when a liquid crystal display such as a Shutter Speed Indicator appears in the finder. (Fig. 13)

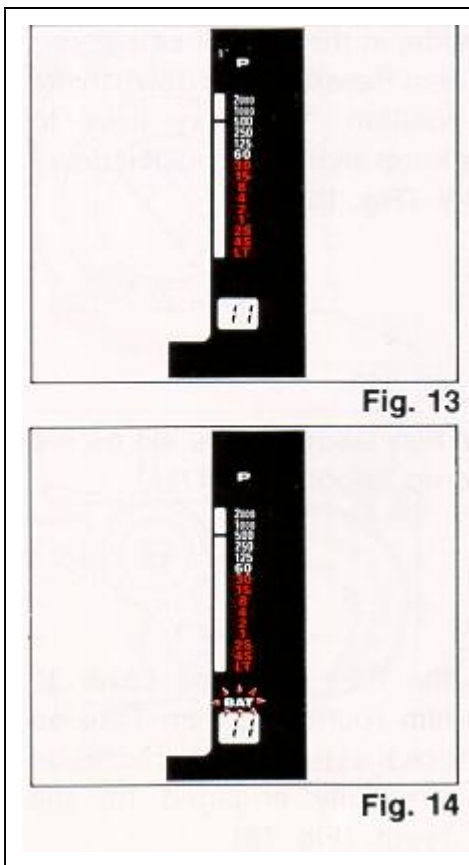

* The BAT (battery low warning) blinks in the finder to warn against their failure when capacity of batteries drops below proper operating level. Change batteries as soon as possible. (Fig. 14)

INSERT THE FILM



Fig. 15

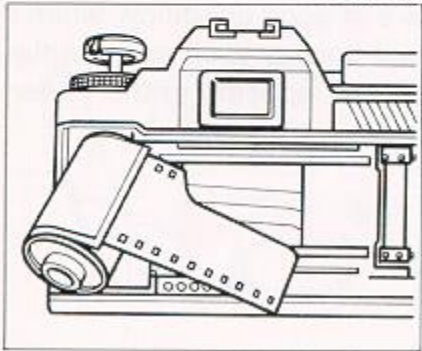

Fig. 16

(Do not expose the film to direct sunlight when inserting the film.)

1. Pull up the Film Rewind Knob until the Back Cover snaps open. (Fig. 15)

2. Insert the film in the Film Chamber and push the Film Rewind Knob down to the original position. You may have to rotate the knob slightly to push it down completely. (Fig. 16)

3. Insert the film leader in the slit on the Film Take-up Spool. (Fig. 17)

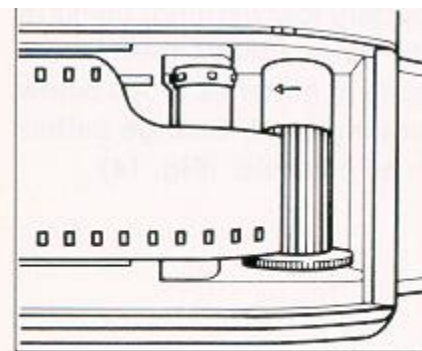

Fig. 17

4. Advance the Film Advance Lever to wind the film round the Film Take-up Spool. Check that the sprocket holes on the film are fully engaged on the Sprocket Teeth. (Fig. 18)

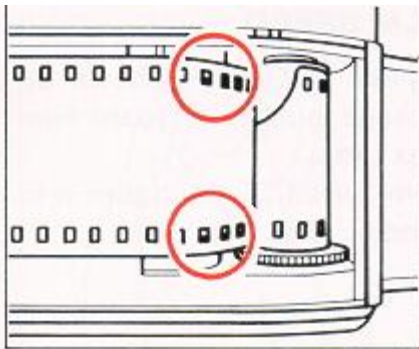

Fig. 18

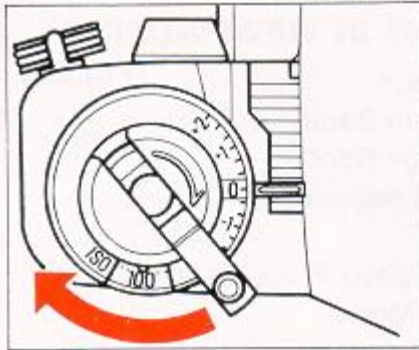

Fig. 19

5. Close the Back Cover, unfold the Film Rewind Crank and turn it gently in the arrow direction until any slack is taken up. (Fig. 19)

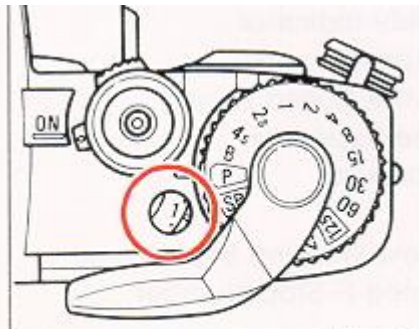

Fig. 20

6. Advance the film and press the Shutter Release Button a few times until "1" appears in the Exposure Counter. The film is properly advanced if the Film Rewind Knob rotates when the Film Advance Lever is stroked to advance the film. (Fig. 20)

* When inserting the film in a cold place, the film leader may be hard and become brittle. Warm the film leader with your hand in such conditions.

* When inserting the film, it is more convenient to set the Shutter Speed Dial to a high speed rather than "P" (Program) while advancing the film to the number 1 position, to avoid a slow shutter speed (the slowest is 16 seconds) When you are ready for shooting, be sure to set the Shutter Speed Dial back to "P" (Program).

SET THE FILM SPEED

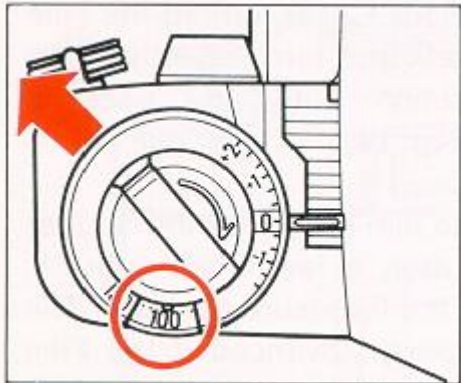

Fig. 21

1. The film speed (ISO/ASA) shown on the film package must be set to the Film Speed Index Line.
2. Pull the Film Speed Dial and turn it to set to the index. (Fig. 21)

INDICATIONS IN VIEWFINDER

- (1) Mat Surface
- (2) Microprism Band
- (3) Split-image Spot
- (4) Exposure Adjustment
- (5) AE Lock
- (6) Manual/Speed Program Mode
- (7) Program Mode
- (8) Overexposure
- (9) Shutter Speed Indicator
- (10) Flash Ready Indicator
- (11) Shutter Speeds
- (12) Slow Shutter Speed Range
- (13) Long Time Exposure
- (14) Underexposure
- (15) Bulb
- (16) Battery Low Warning Signal
- (17) Programmed F-Stop Number

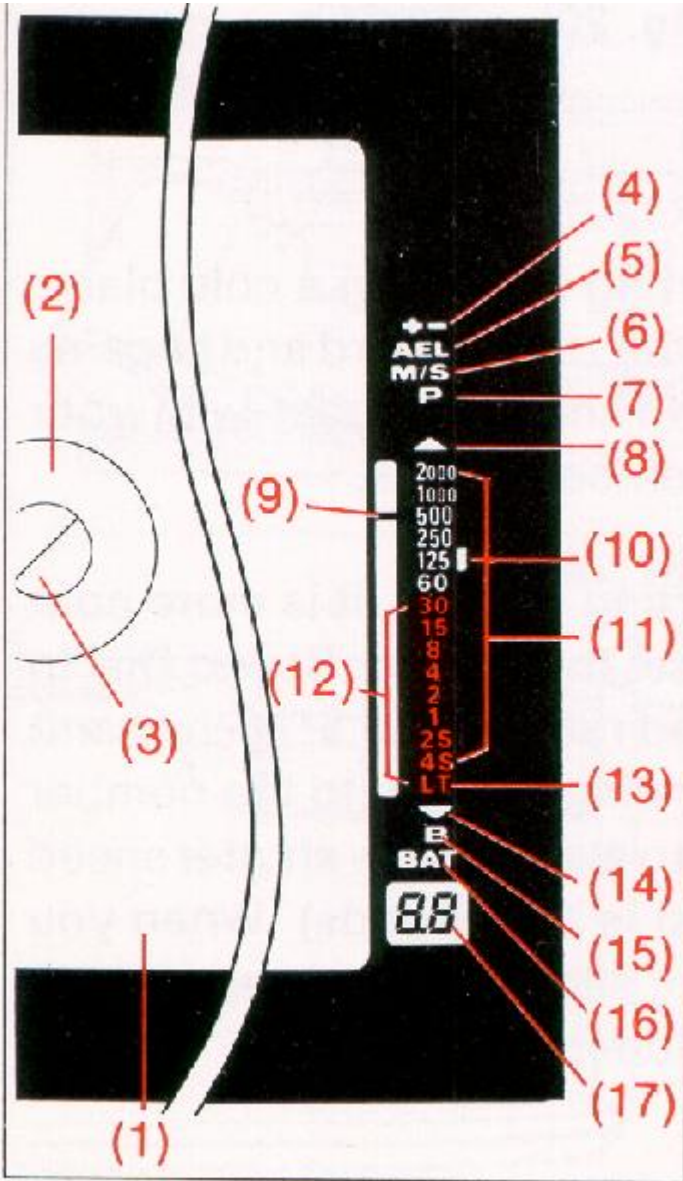

Fig. 22

HOW TO HOLD YOUR CAMERA



Fig. 23

(Good position for photography)

- (1) Lightly put your right-hand forefinger on the Shutter Release Button and hold the camera body with other fingers.
- (2) Make your right arm comfortable.
- (3) Cradle your camera in your left hand and hold it so that the Focusing Ring can be easily turned with fingers.
- (4) Brace your left elbow to your body ||| and put the camera to your face. Look through the viewfinder to compose your picture. (Fig. 23)

* It is important to practice correct shooting position to avoid blurred or tilted pictures.

PROGRAM AE PHOTOGRAPHY

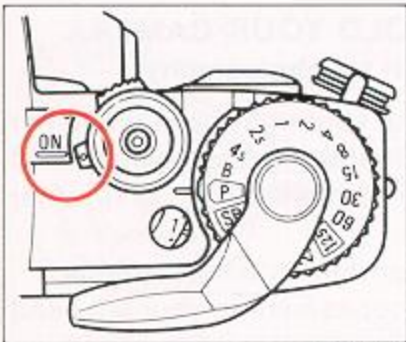

Fig. 24

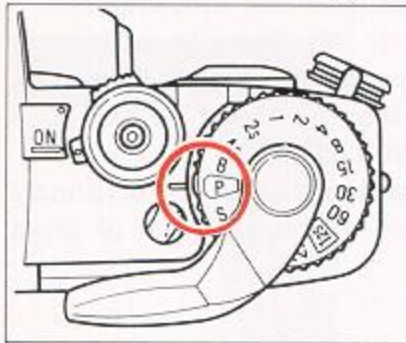

Fig. 25

In program AE photography, the camera automatically selects the f-stop number and the shutter speed according to subject illumination. Programs are best for general photos of figures or scenery. Special effects shooting etc., can be done using the XR-20SP's multitude of override options. Please keep in mind however that for most shooting you can just focus and snap.

1. Turn the Power ON-OFF Switch ON. (Fig. 24)
2. Set the Shutter Speed Dial to "P". (Fig. 25)

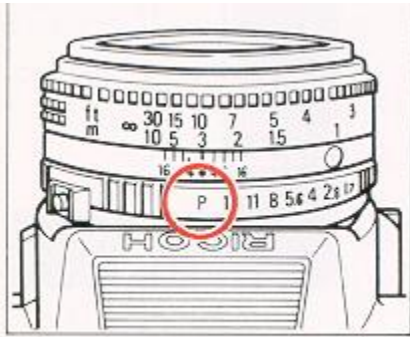

Fig. 26

3. Set the lens to "P". (Fig. 26)

4. Look through the viewfinder and turn the Focusing Ring to focus. You can focus either by using the Split Image or Microprism.

SPEED PROGRAM (SP) AE PHOTOGRAPHY

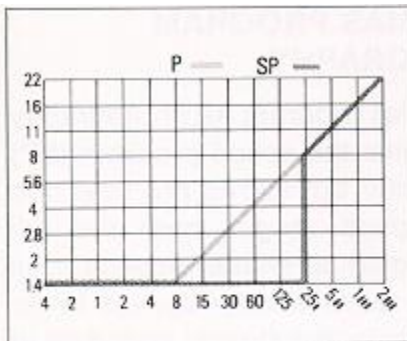
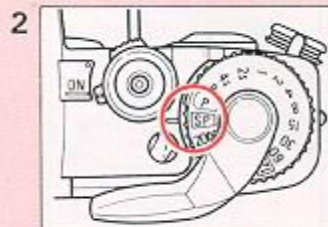
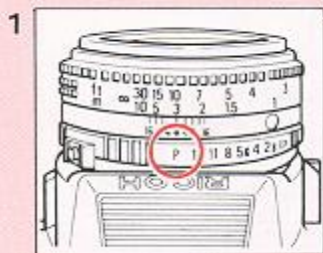

Fig. 27

The speed program AE photography is a combination of the program AE photography and shutter speed priority AE photography. Use this mode to avoid shutter speeds slower than 1/250 second. (Fig. 27)





MANUAL

1. Turn the F-Stop Ring to set to "P".

2. Turn the Shutter Speed Dial to set to "SP".

When the subject is bright enough, any shutter speed between 1/250 and 1/2000 sec. will be selected according to the brightness of the subject, and you can see the selected shutter speed as well as f-stop number in the viewfinder. If the brightness of the subject is not enough even at full-open aperture, a slower shutter speed is automatically selected to obtain correct exposure. In this case, the Shutter Speed Indicator blinks to warn that a slower shutter speed than 1/250 is selected.

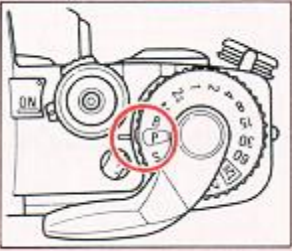
APERTURE-PRIORITY AE PHOTOGRAPHY

 <p>1</p> <p>Diagram 1 shows a close-up of the camera's shutter speed dial. The dial is rotated so that the letter 'P' (Program) is aligned with the white indicator mark. A red circle highlights the 'P' and the indicator mark.</p>	 <p>2</p> <p>Diagram 2 shows the camera's lens with the F-stop ring. The ring is rotated so that the number '11' is aligned with the white indicator mark. A red circle highlights the '11' and the indicator mark. Below the diagram, the word 'MANUAL' is written.</p>
---	---

In aperture-priority AE photography, the camera automatically sets correct shutter speeds according to a pre-selected f-stop number and brightness of subjects. This is suitable for photography taking advantage of specific depth-of-field results as in portraits or scenery pictures.



1. Set the Shutter Speed Dial to "P".

2. Turn the F-Stop Ring to set the desired f-stop number.

When the Shutter Speed Indicator is in the orange range, the shutter speed is too slow. Select a new f-stop number or mount the camera on a tripod or other suitable platform.

* When overexposure mark (up arrow) or underexposure mark (down arrow) appears in the viewfinder, exposure is not correct. Turn the F-Stop Ring to change the f-stop number.

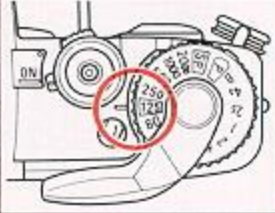
MANUAL PHOTOGRAPHY

 <p>1</p> <p>Diagram 1 shows a close-up of the camera's shutter speed dial. The dial is rotated so that the number '1/250' is aligned with the white indicator mark. A red circle highlights the '1/250' and the indicator mark. Below the diagram, the word 'MANUAL' is written.</p>	 <p>2</p> <p>Diagram 2 shows the camera's lens with the F-stop ring. The ring is rotated so that the number '11' is aligned with the white indicator mark. A red circle highlights the '11' and the indicator mark. Below the diagram, the word 'MANUAL' is written.</p>
--	---

Select manual mode to manually set the shutter and the f-stop number in unusual or creative picture taking situations.

1. Set the Shutter Speed Dial to the desired speed.

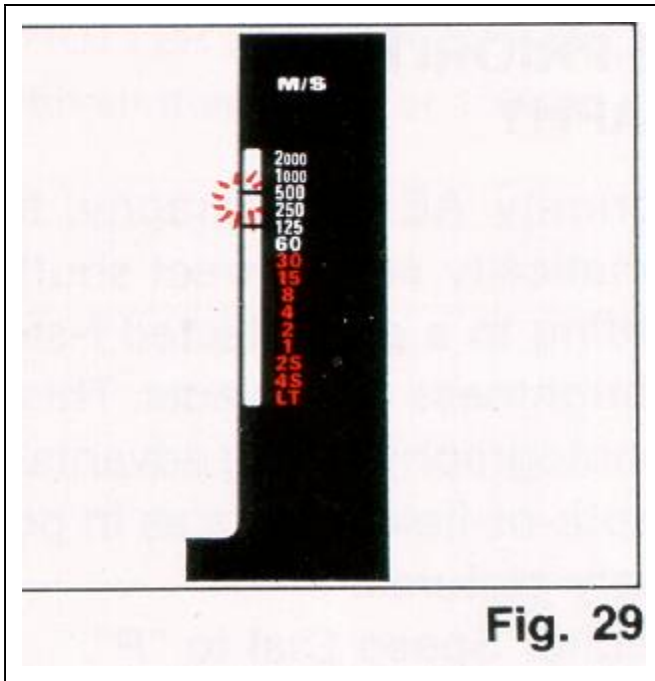

2. The pre-set shutter speed is shown by the Indicator on the LCD meter display. A second Indicator blinks to indicate a "suggested" speed at a given f-stop. (Fig. 29)

3. When the F-Stop Ring is turned and the Shutter Speed Indicator and the blinking Indicator showing correct exposure overlap each other. This indicates that correct exposure is set.

(Webmaster - In ENGLISH this means: the solid bar is what the shutter is currently set at, you can change the camera's shutter speed dial and see the new setting in the viewfinder . You must change the shutter or aperture to get the solid bar [what the shutter is set on the camera] to overlap the blinking bar [what the light meter says is the correct exposure]. When the blinking bar and solid bar overlap, that is the correct exposure for whatever the lens is pointing at that moment. You can then change the shutter one speed and then adjust the aperture for more/less light so the two bars still overlap. **EXAMPLE:** if you get the two bars to overlap and the shutter speed is set at 1/125 at F16, you can change the shutter to 1/250 at F11, 1/500 at F8 or 1/60 at F22. (Note: you couldn't shoot slower than 1/60 with that lighting situation as this time as most lenses don't go smaller than F22. If you do have yet a smaller aperture, it would be 1/30 at F32)

FOCUSING

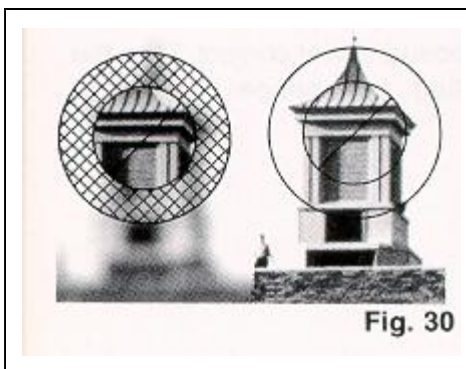

Split Image Focusing

When the split images in the Split-Image Spot form a single, clear image, the subject is in focus.

Microprism Focusing

When the subject loses its "shimmering" effect and becomes very sharp, the subject is in focus.

REWIND THE FILM

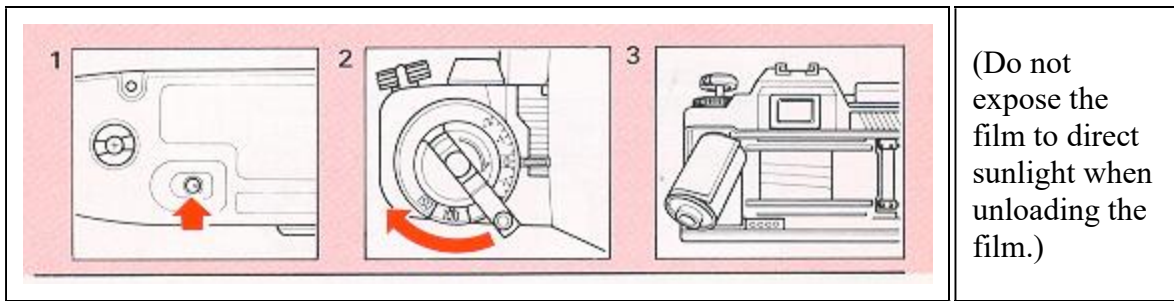

(Do not expose the film to direct sunlight when unloading the film.)

1. Push the Film Rewind Release Button. The button stays locked in position (Fig. 31)

2. Unfold the Film Rewind Crank and turn it in the arrow direction. When the film has been completely rewound, the tension of the Film Rewind Crank is suddenly released and turns freely. (Fig. 32)

3. Open the Back Cover and unload the film. (Fig. 33)

* Never open the Back Cover until film rewinding is completed. Immediately close the Back Cover to save some of your shots if the Back Cover is opened by mistake during or before rewinding.

* If you wind the film beyond the set number of frames, the Film Advance Lever may get stuck mid-stroke. The Film Rewind Release Button will not stay depressed in. If this occurs, rewind the film while holding the Film Rewind Release Button pressed down.

SELF-TIMER PHOTOGRAPHY

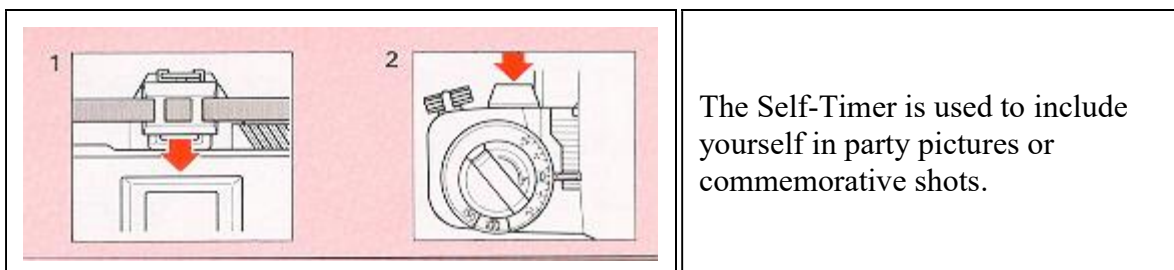

The Self-Timer is used to include yourself in party pictures or commemorative shots.

1. Advance the film.

2. Press the Self-Timer Button. The Self Timer Indicator Lamp blinks. In 10 seconds, the shutter is automatically released. (Fig. 34)

* To cancel the Self-Timer after it is set, press the Self-Timer Button again.

* Use the Viewfinder Cap attached to the strap to cover the Viewfinder Eyepiece when using the Self-Timer in modes other than "Manual" to avoid incorrect exposure due to incident-light from the Viewfinder Eyepiece. (Fig. 35)

* B (Bulb) setting is not available when the Self-Timer is used.

FLASH PHOTOGRAPHY (PROGRAMMED FLASH PHOTOGRAPHY)



If the RICOH SPEEDLITE 300P or 240 is used on the RICOH XR-20SP camera, the shutter speed and the f-stop number are automatically set with the camera is set to program AE photography.

1. Slide the flash unit into the Hot Shoe and tighten it with the lock screw. (Fig. 36)

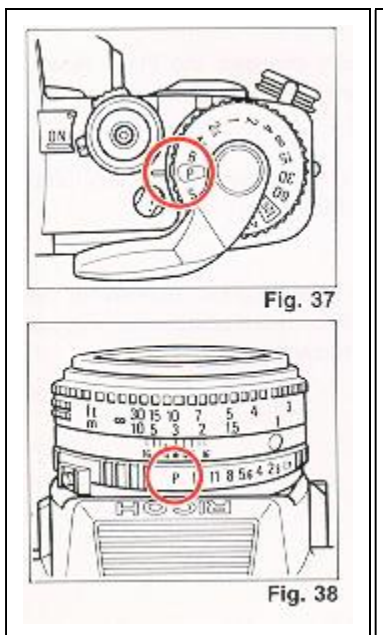

2. Set the Shutter Speed Dial to "P" or "SP". (Fig. 37)

3. Set the F-Stop Ring to "P". (Fig. 38)

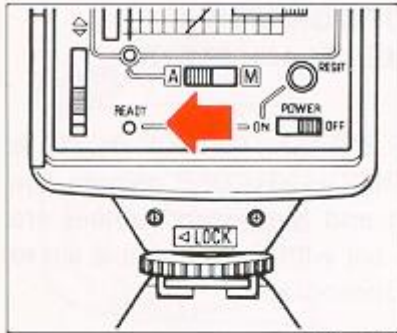

Fig. 39

4. Set the flash A/M selector to "A". (Fig. 39)

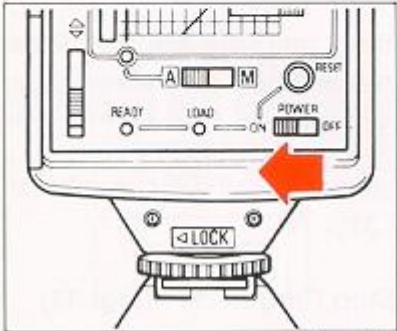

Fig. 40

5. Turn the flash power On-Off switch ON. (Fig. 40)

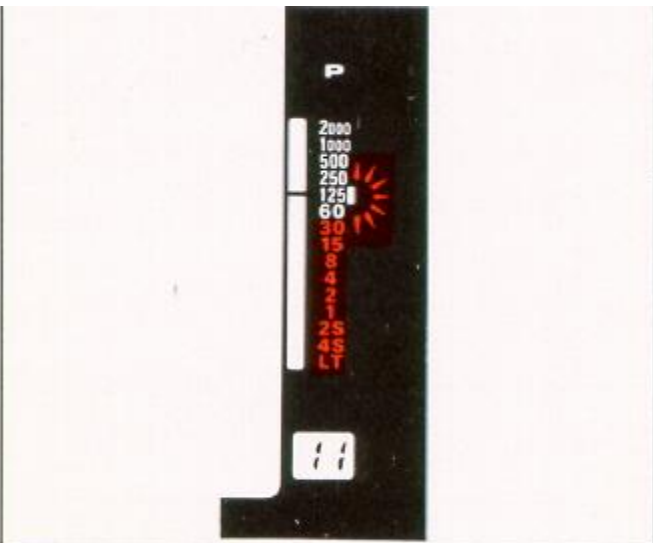

Fig. 41

6. When fully charged, the Flash Ready Indicator (red LED) lights in the finder. (Fig. 41)

Focus the subject and press the Shutter Release Button for shooting.

* Refer to Operating Instructions for the flash unit for more creative techniques and technical details.

FLASH PHOTOGRAPHY WITH RICOH FLASH UNIT OTHER THAN 300P & 240

1. RICOH flash units (SPEEDLITE 400 and 180) can be used with XR-20SP with the Shutter Speed Dial set to "P" or "SP" and with the F-Stop Ring set to the designated number. When the flash is fully charged, the Flash Ready Indicator in the viewfinder will light up.

* Shutter speed is automatically set to 1/125 sec.

* You may set shutter speed and f-stop number manually but shutter speed must be slower than 1/125 sec., however, when you select shutter speed faster than 1/125 sec., the shutter speed is automatically set to 1/125 sec.

* Refer to Operating Instructions for flash units for further details.

FLASH PHOTOGRAPHY WITH "NON-DEDICATED" FLASH UNITS

(General use of flash)

1. Set the Shutter Speed Dial to 1/125 sec. when a generic flash unit is used.

Note: Such units cannot be used in P mode.

* Avoid use of flash units other than RICOH with special contact pins, incorrect exposure or other problems may result.

* The Flash Ready Lamp does not light in the viewfinder if such a "non-dedicated" flash is used.

* Refer to operating instructions for these flash units for further details.

EXPOSURE COMPENSATION

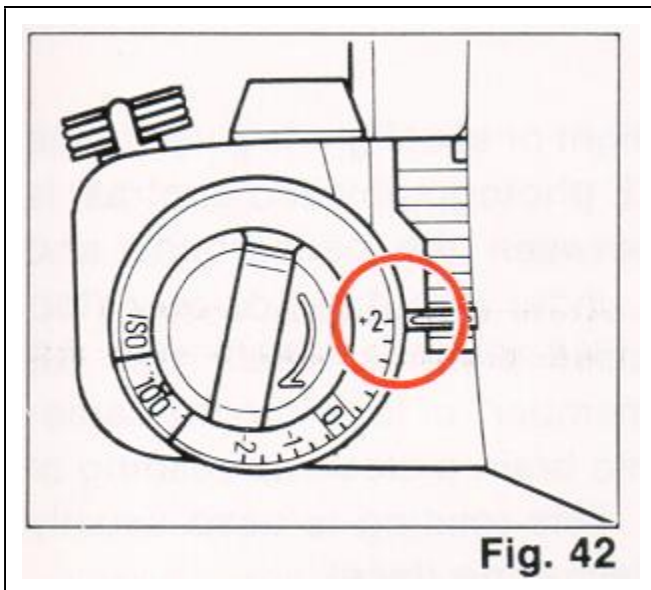

The XR-20SP center-weighted meter can be "fooled" under very extreme lighting conditions.

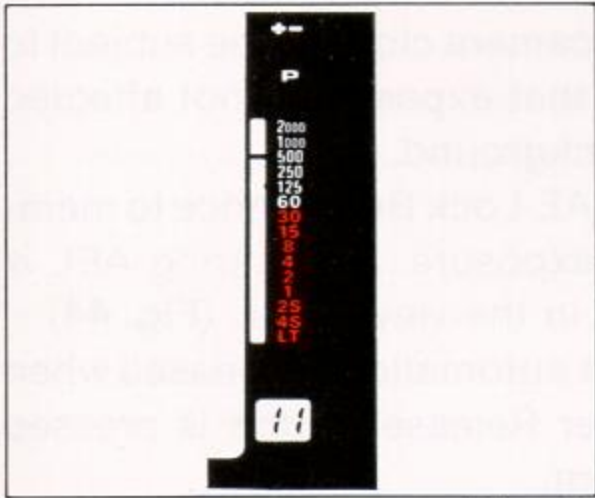

Fig. 43

When back light or spot light is given to the subject in AE photography and contrast is excessive between the background and the subject, under (dark) or over (too bright) exposed pictures result. Exposure compensation is used in such cases. It is also used to intentionally take over or underexposed pictures for creative effects etc.

1. Turn the Exposure Compensation Dial to set it to the required number. (Fig. 42)

* Be sure to set it back to "0" position after use.

* When the Exposure Compensation Dial is set at positions other than 0, you will see a + or a - displayed on the viewfinder LCD. (Fig. 43)

Exposure adjustment examples:

SUBJECT	EXPOSURE ADJUSTMENT
Figures in back light Scenery with much light	+2 to +1
Figures with snow mountains or sea on the background	+1
Figures in spot light (on stage etc.)	-2 to -1

AE LOCK

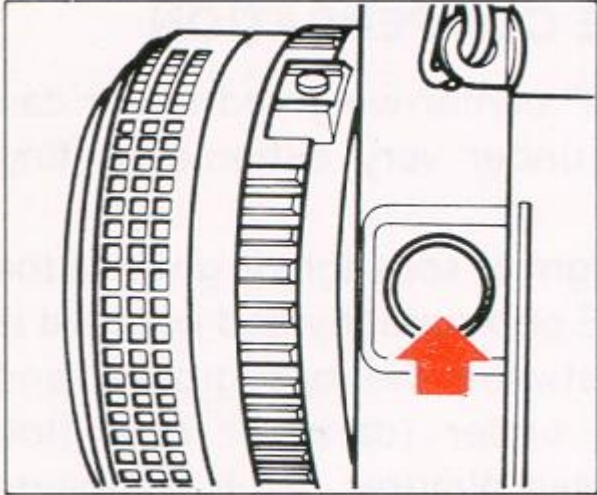

Fig. 44

When back light or spot light is given to the subject in AE photography and contrast is excessive between the background and the subject, under (too dark) or over (too bright) exposed pictures result. Use AE Lock to "remember" or lock into the camera's electronic brain a close-up reading of the subject. This reading is used usually taken of a flesh-tone (face).

1. Bring the camera close to the subject to the point that exposure is not affected by the background.
2. Press the AE Lock Button once to memorize the exposure. A flickering AEL is displayed in the viewfinder. (Fig. 44)
3. AE Lock is automatically released when the Shutter Release Button is pressed for the shot.

* Press AE Lock Button a second time to cancel without taking a picture.

* AE Lock can be used continuously if the AE Lock Button is kept pressed in.

DEPTH OF FIELD (GENERAL GUIDE LINES)

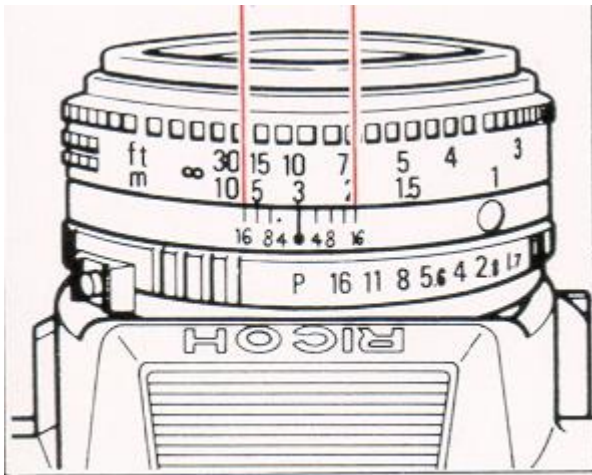

Fig. 45

When you focus on a specific subject, often subjects in the near foreground and in the distance are also in focus. The region of good focus has some measurable depth, or "depth of field" as shown here.

1. Focus depth in the near foreground is narrow and deeper with distance.
2. Greater depth of field is obtained with smaller lens opening and a wider range of good focus is provided.
3. A lens of shorter focal length (wider angle) produces a greater depth of field. A greater depth is obtained with a wide angle lens (E.G. 28 mm) and a smaller depth is obtained with a telephoto lens (E.G. 135 mm).

The depth of field can be checked in the following way.

1. A depth of field indicator is engraved on every lens. When a 50 mm standard lens is set to f-16 and focused at a distance of 3 meters, the depth of field indicator is the scale of numbers on each side of mark, ranging from 16 to 16 (about 2m to em). Subjects in this distance range will be in good focus. (Fig. 45)

B (BULB) SETTING

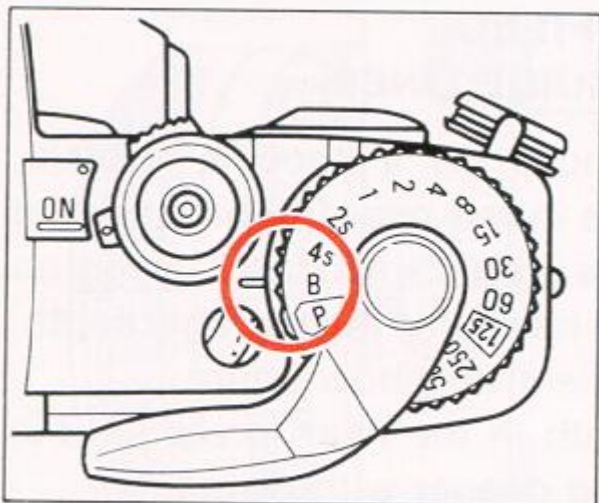

Fig. 46

The B (Bulb) setting is used for shooting night scenes or long time exposures.

1. Set the Shutter Speed Dial to "B". (Fig. 46)
2. When the Shutter Release Button is pressed, the shutter is kept open as long as the Button is pressed.

* Use a tripod and cable release for Bulb photography to prevent unintentional movement of the camera.

VIEWFINDER LIGHTING

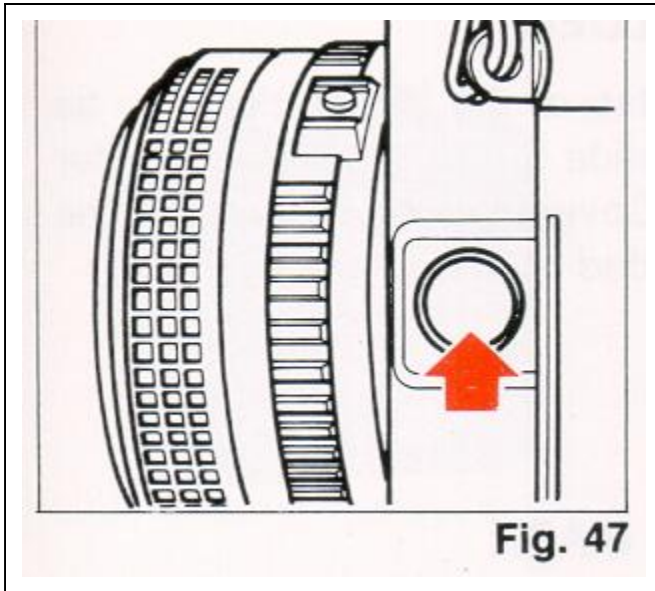

Auxiliary lighting can be used when the finder area is dark and difficult to see. Press the AE Lock Button to activate the LCD Illuminator. This also "memorize" the exposure data.

Press AE Lock Button once again to unlock AE, and to return to normal operation. (Fig. 47)

POWER ON-OFF SWITCH

XR-20SP is designed to shut off the power supply automatically to save the battery energy, i.e. the electric supply will be shut off automatically when the camera is not in use for 1 minute even the Power ON-OFF Switch is ON. Press the Shutter Release Button lightly to turn ON the power. However, we suggest you should turn the Power ON-OFF Switch to the OFF position when the camera is not used.

MEMO HOLDER

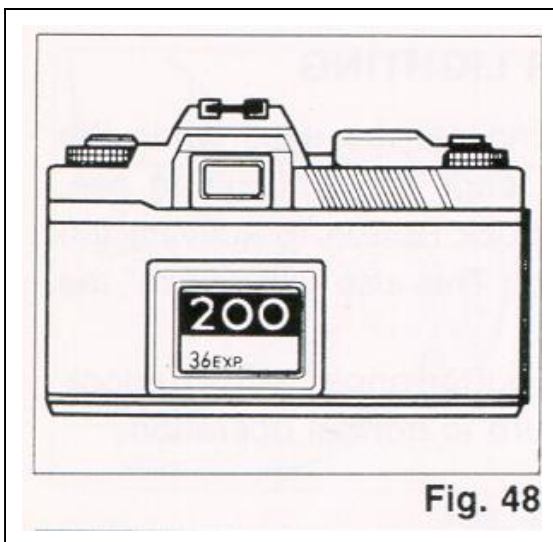

Cut off the flap of the film package to be loaded and slide it into the Memo Holder on the Back Cover to remind you what type of film is loaded in the camera. (Fig. 48)

INFRARED MARK

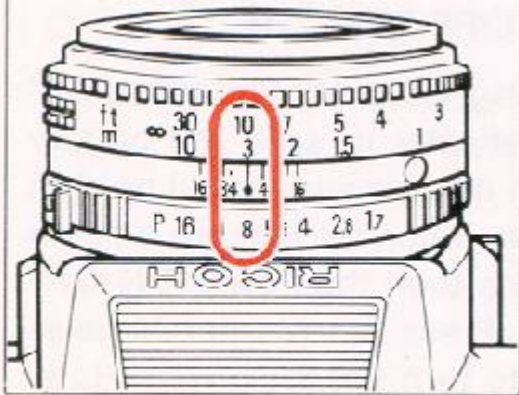

Fig. 49

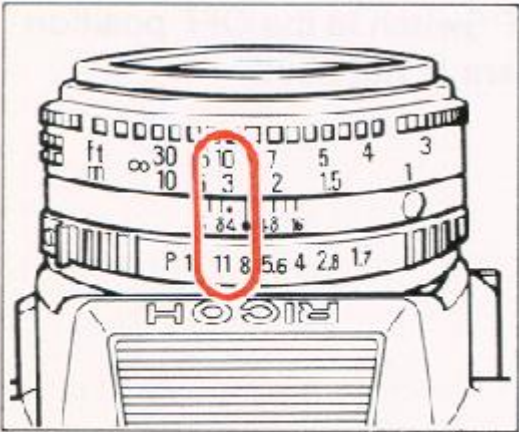

Fig. 50

Use the Infrared Focusing mark when using infrared film and R60 filter.

This is necessary because infrared light rays have a longer wave length than visible light rays, visual focusing will not be accurate without some compensation.

1. Attach the R60 filter and focus on the subject. Read the distance from the lens barrel. (Fig. 49)
2. Shift the distance setting to the infrared index mark. (Fig. 50) Set the exposure and release the shutter in accordance with operating instructions for the film.

* Always refer to infrared film operating instructions when the infrared film is used.

XR WINDER 2



Fig. 51



Fig. 52

XR winder 2 is the automatic film winding device for XR-20SP.

When this is used on XR-20SP, you need not avert your eyes from the viewfinder to advance the film during fast action photography. This means fewer missed photo opportunities and better compositions.

This is very convenient in taking sports pictures, 2 frames per second can be taken if the Shutter Release Button is kept pressed. One frame shooting is possible when the Shutter Release Button is released quickly. 4 AA 1.5V batteries (manganese, alkaline, or nickel cadmium) are used for its power source. (Fig. 51)

XR DATA BACK

2 When the Back Cover of XR-20SP camera is replaced by the XR Data Back, "Year, month and date" "Hour, minute, second" and "Stop watch" can be printed on your film.

The automatic dating mechanism is incorporated into the XR Data Back. Once the date is set, no adjustment is necessary until 1999, because leap years and months with 31 or less days are automatically adjusted. When the switch is turned OFF, it can be used as digital watch. (Fig. 52) (Mike - I don't have one so I can't tell you if it is Y2K compliant)

DIOPTRIC LENSES

If a dioptric lens is fitted, you do not have to wear eye-glasses when taking pictures. Slip the lens in the groove in the finder eyepiece.

Dioptric lenses are available in 7 types: -4, -3, -2, -1, +1, +2 and +3 (Diopters) (Fig. 53)

Note: Some forms of astigmatism etc. may make dioptric eyepiece correction impossible. Please check with your vision specialist for a recommendation based on your prescription.

RELEASE GRIP



Fig. 54

The release grip is available for the XR-20SP as an optional accessory.

1. Push the hand grip release button on the bottom of your camera to remove the standard grip. (Fig. 54)
2. Press two release grip pegs into camera body holes to snap the release grip into place. (Fig. 55)



Fig. 55

P MOUNT ADAPTER

Conventional P mount lens (thread mount lens) can be used on XR-20SP by using the optional P mount adapter. Normal photography is available but operating conditions are slightly changed.

(Webmaster - Yes, you can mount a thread mount lens on this and other K-mount cameras but the thread mount lens must have a manual aperture setting. You must stop down [darken viewfinder] to take a meter reading and then open wide to focus accurately, then close to the correct aperture to take a photo.

- A. Program exposure does not work (due to a different lens coupling system).
- B. Auto (Full Aperture) diaphragm is not functional.
- C. Automatic f-stop number setting with the special flash unit is not functional.



Fig. 56

1. Align with the red dot and attach it into the body mount. (Fig. 56)

2. Use a ball-point pen, etc. to turn it clockwise to the limit (65°). It is then locked and ready for use.

3. Use a ball-point pen, etc. to press the spring inwards and turn the P mount adapter counterclockwise to the limit. Now it can be removed.

* Some thread mount lenses cannot be mounted on the XR-20SP camera. Purchase of lenses for XR-20SP is recommended for optimum results.

CARE OF BATTERIES

1. After handling, do not leave sweat or grease on battery surface. This could result in poor contact. Wipe both ends of the battery with a clean cloth.
2. Do not attempt to disassemble the batteries and do not throw them into fire or expose to high temperatures.
3. When batteries are unloaded from the camera, keep them away from children. If a child should swallow a battery, immediately consult with a doctor. Battery chemicals are highly poisonous.
4. Unload batteries when the camera is not used for a long period of time.

CARE AND STORAGE OF YOUR CAMERA

- * Do not touch the lens or mirror with your fingers to clean them. Blow dust away with a blower or wipe them gently with soft cloth.
- * Shock, humidity or salt may make the camera malfunction. When you use your camera at the beach or in a place where chemicals are used, wipe it clean carefully.
- * Do not use chemically-treated dusters to clean the camera.
- * Do not expose your camera to temperature extremes.

* Do not leave your camera in a car or at the beach or in high temperature conditions to prevent possible trouble. When using a tripod, do not try to force a long screw into the socket. (The screw length should be less than 5.7 mm)

* Do not store your camera near a television, radio or other magnetic substance.

* Remove batteries from your camera before storing it. Store it in a humidity and dust free place.

SPECIFICATIONS

Type: 35 mm SLR with focal plane shutter and automatic electronic exposure control.

Photographic Modes: Program automatic exposure mode, speed program automatic exposure mode, aperture-priority automatic exposure mode and manual exposure mode.

Film Format and Frame Size: 35mm film, J135, 24 x36 mm

Lens Mount: RICOH system R-K mount

Shutter: Electronically controlled, vertically moving metal focal plane shutter.

Automatic: 16 sec. to 1/2000 sec.

Manual: 4 sec. to 1/2000 sec.,

B (Bulb)

Self-Timer:

Operating time: 10 seconds View finder. During operation, red lamp blinks.

Viewfinder:

Field of view covers 93% horizontally and vertically.

Magnification: 0.88X (with 50 mm F1.4 standard lens)

Displays in the viewfinder:

Exposure adjustment, AE lock, manual, program mode, overexposure mark, shutter speed indicator, long time exposure, underexposure mark, bulb, battery low warning signal, and programmed f-stop number. LED indicator: Flash ready indicator.

Focusing: Diagonal split-image spot in micropism band

Exposure Meter: TTL full open metering for center-weighted average light reading.

Exposure Coupling Range: EV 0 to EV 18 (with ASA 100 film, 50 mm F1.4 standard lens)

Film Speed Range: ISO 12 to 3200

Accessory Shoe: Hot Shoe (with Flash Ready Signal Contact)

Exposure Adjustment: Exposure adjustment system (+2 to -2, in 1/3 steps), AE lock system,

Film Advance: Single stroke film advance lever, 135° winding angle and 35° stand-off.

Automatic Film Advance: Possible with XR winder 2 or motor drive.

Exposure Counter: Additive, automatic resetting.

Film Rewind: Film rewind crank system.

Mirror: Swing back type quick return mirror.

Back Cover: Hinged type, opened by pulling up Film rewind knob.

Other Functions: Interchangeable grip and direct contact for data back.

Power Source: Four LR44 1.5V alkaline batteries, four SR44 1.55V silver oxide batteries or two CR-1/3N 3V lithium batteries.

Dimensions: 137 (W) x 89 (H) x 51 (D) mm (Body only)

Weight: 490g (Body only)