

Ricoh AF-45

posted 8-10-'03

This camera manual library is for reference and historical purposes, all rights reserved.

This page is copyright © by mike@butkus.org, M.Butkus, NJ.

This page may not be sold or distributed without the expressed permission of the producer.

I have no connection with any camera company

On-line camera manual library

[Back to main camera manual page](#)

If you find this manual useful, how about a donation of \$3 to:

**M. Butkus, 29 Lake Ave., High Bridge, NJ 08829-1701
and send your e-mail address so I can thank you.**

**Most other places would charge you \$7.50 for a electronic copy
or \$18.00 for a hard to read Xerox copy.**

**This will help me to continue to host this site,
buy new manuals, and pay their shipping costs.**

It'll make you feel better, won't it?

If you use Pay Pal, use the link below.

Use the above address for a check, M.O. or cash.



www.PayPal.me/butkus

Venmo @mike-butkus-camera Ph. 2083

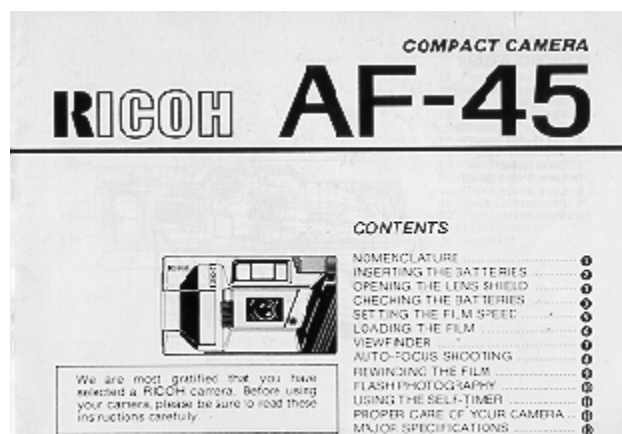

NOMENCLATURE

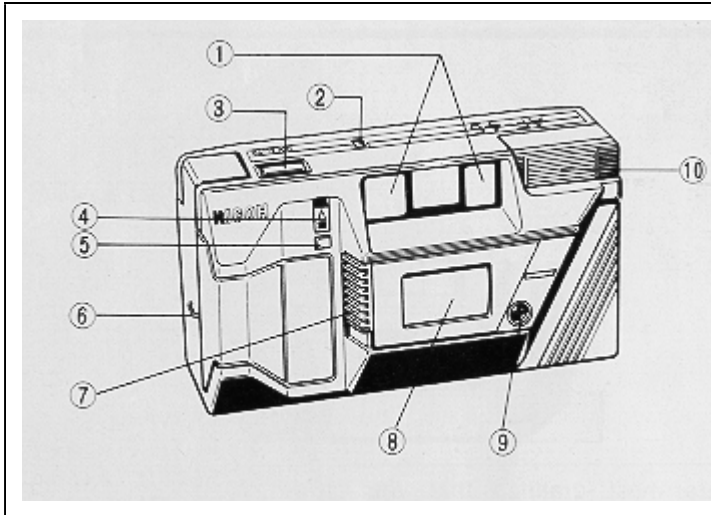

1. Distance Measuring Window
2. Film Counter
3. Shutter Release Button
4. Self-Timer Switch
5. Self-Timer LED
6. Strap Eyelet
7. Lens Shield Switch
8. Lens Shield
9. Photocell
10. Flash Unit

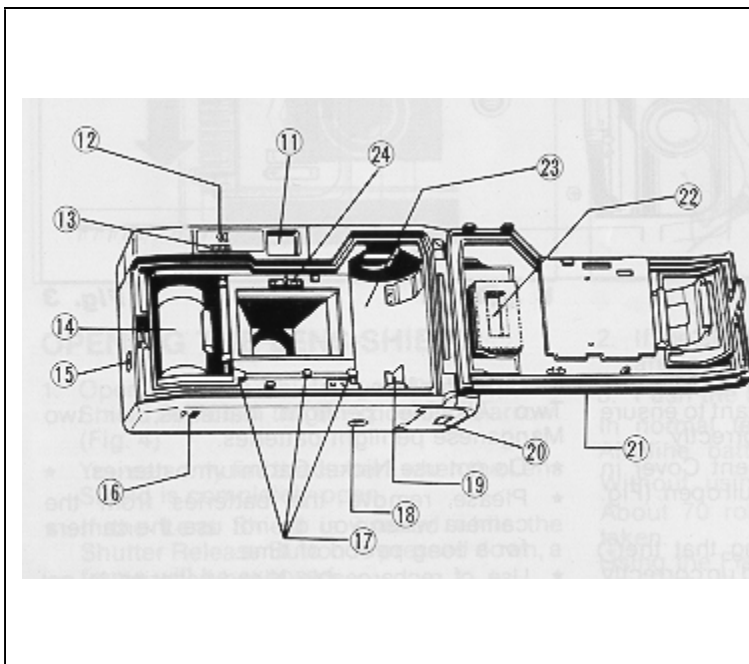

11. Viewfinder Eyepiece
12. Film Advance/Rewind Monitor
13. Flash Ready Lamp
14. Film Take-up Spool
15. Back Cover Lever
16. Manual Film Rewind Switch
17. Film Guides
18. Tripod Socket
19. Film Rewind Shaft
20. Battery Compartment Cover
21. Back Cover
22. Film Loaded Window
23. Film Chamber
24. Sprocket

INSERTING THE BATTERIES

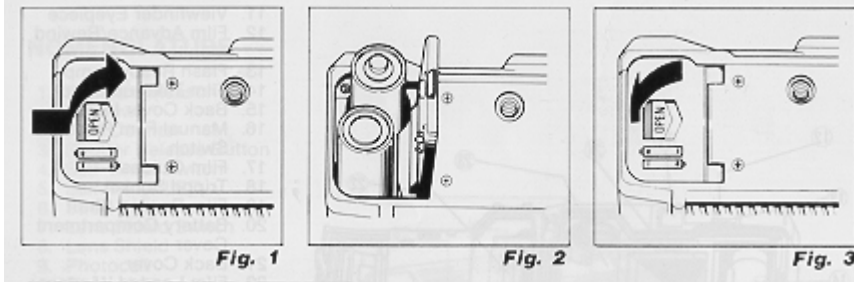

The camera will not operate unless the batteries are installed. It is important to ensure that the batteries are inserted correctly.

1. Push the Battery Compartment Cover in the direction of the arrow to pull open. (Fig.1)
2. Insert two batteries, checking that the (+) and (-) on the batteries are lined up correctly according to the polarity diagram inside the battery compartment. (Fig. 2)
3. Close the Battery Compartment Cover by pushing it in the direction of the arrow. (Fig. 3)

Batteries for Use

Two Alkaline penlight batteries, or two Manganese penlight batteries.

- * Do not use Nickel Cadmium batteries.
- * Please remove the batteries from the camera when you do not use the camera for a long period of time.
- * Use of rechargeable NiCad batteries is not recommended. Due to higher internal amperage, the electronics in your Ricoh camera/flash unit may be damaged. If damaged due to use of NiCad batteries occurs the warranty will be considered null and void.

OPENING THE LENS SHIELD

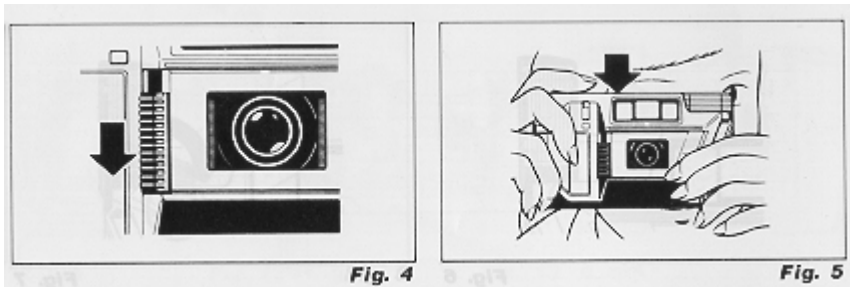

1. Open the Lens Shield by sliding the Lens Shield Switch in the direction of the arrow. (Fig 4)

- * You can only fire the camera when the Lens Shield is completely open.
- * If the Lens Shield is opened while the Shutter Release Button is pressed down, a frame will be exposed.

CHECKING THE BATTERIES

1. Cover the Photocell with **your hand and** press the Shutter Release Button in halfway. (Fig 5)
2. If the Flash Unit pops up, then the batteries are in working order. (Fig. 6)
3. Push the Flash Unit back down. (Fig. 7)

In normal temperature (at 20° C, with new Alkaline batteries)

Without using the Flash Unit:

About 70 rolls of 36 exposure film can be taken. Using the Flash Unit repeatedly: About 7 roll of 36 exposure film can be taken.

Please change both batteries to new ones of the same kind in the following cases:

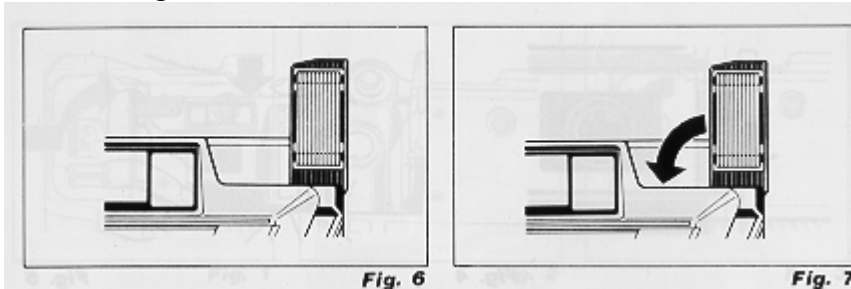

- a. The Flash Unit does not pop up when you have covered the Photocell with your hand and the Shutter Release Button is pressed in halfway.
- b. The shutter cannot be released (apart from when the Lens Shield is closed).
- c. The Flash Ready Lamp takes more than 30 seconds to light up.
- d. The film advance or Film Rewind does not operate.
- e. The batteries have been in the camera for more than one year. (Even without using the camera, the batteries will lose power naturally.)

Generally, in cold conditions, the capacity of the batteries decreases, and in some cases, the camera may not operate correctly. You should either warm the batteries or keep a spare set in your pocket, inserting them just before you use the camera. Incidentally if the capacity of the batteries has decreased in cold temperatures, it will regain full capacity in normal temperatures, so do not throw the batteries away.

SETTING THE FILM SPEED

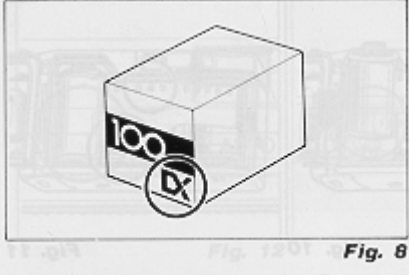
 <p>Fig. 8</p>	<p>Please check whether the film has a DX code system or not (Fig. 8)</p> <p>(A film with a DX code, Setting the film speed is not necessary. The camera automatically makes the correct film speed setting.</p> <p>(A film without DX code) If non-Ding film is loaded in the camera, the camera will automatically set itself to ISO 100. * Please be careful when you take a picture with ISO 1000 film in bright sunlight, the picture may be overexposed.</p>
---	--

LOADING THE FILM

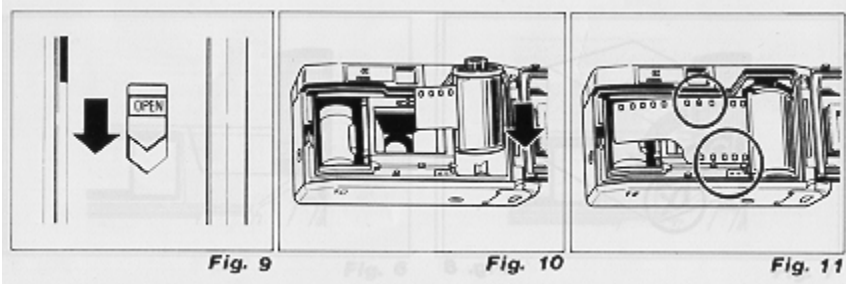

1. Push the Back Cover Lever downwards in the direction of the arrow to open. (Fig. 9)
2. Load the film into the Film Chamber and pull out the film leader, placing it over the Film Take-up Spool. (Fig. 10)
3. Please make sure that the film is within the Film Guides. (Fig. 11)
4. Press the Back Cover shut so that the Back Cover Lever returns to its original position. The film is automatically advanced until number "1" appears in the Film Counter Window. (Fig. 12)
5. If the Film Advance/Rewind Monitor rotates rapidly, then the film is advancing correctly. If the monitor does not rotate, the film has not advanced correctly, so please reload the film. (Fig. 13)

* Always avoid direct sunlight when loading the film.

* The Film Loaded Window is to confirm whether film is loaded or not.

VIEWFINDER (Fig. 14)

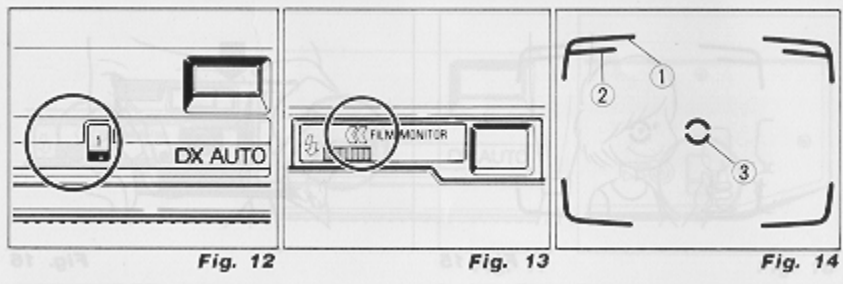

1. Field of View Frame

The subject (such as people or scenery) that you wish to take should be set within this frame.

2. Parallax Correction Marks

When taking a picture of a subject that is between 1 - 1.2m (3.3 - 4 ft.) away from the camera, the subject should be positioned within these marks. Anything outside the marks will not be included in the picture even though you can see it through the viewfinder.

3. Auto-Focus Frame The Auto-Focus system focuses automatically on any subject that appears within this small square.

AUTO-FOCUS SHOOTING

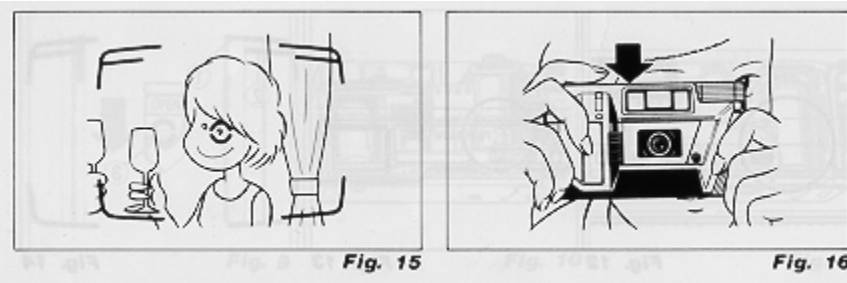

1. Set the subject you wish to take within the Auto-Focus Frame in the center of the viewfinder. (Fig. 15)
2. When you press the Shutter Release Button halfway, the subject is focused.
3. Gently press the Shutter Release Button down to take the picture. The film will advance automatically as soon as the shutter has been released. (Fig. 16)

* Please be careful not to cover the Distance Measuring Window at the front of the camera accidentally, as this will cause incorrect focusing.

* Please keep the Distance Measuring Window clean so that focusing is accurate. If it gets dirty, it should be wiped clean with a soft cloth.

REWINDING THE FILM (Auto Reverse)

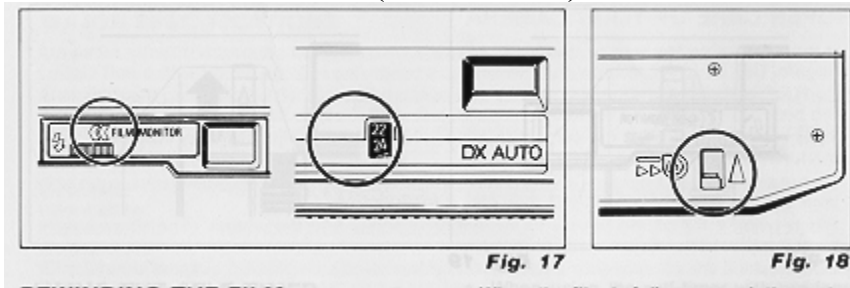

After the end of the film has been reached, the film is automatically rewound.

* As the film is being rewound, the Film Advance/Rewind Monitor will rotate and the Film Counter will run backwards.

(Fig. 17)

* When the film is fully rewound, the motor stops automatically and "S" is seen in the Film Counter. You can now open the Back Cover to unload the film.

* If you wish to rewind the film before the end of roll is reached, push the Manual Film Rewind Switch with a ball point pen, etc. (Fig. 18)

* You can close the Lens Shield when the film is being rewound.

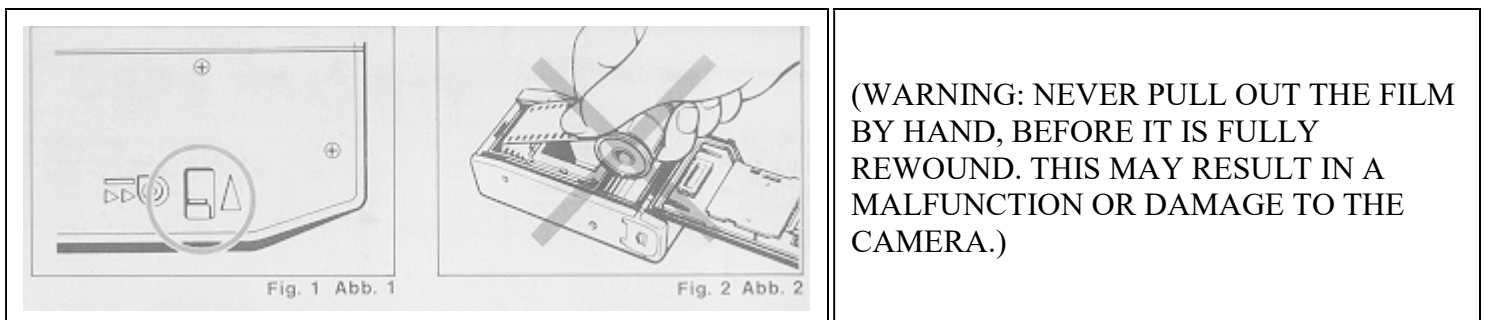

(WARNING: NEVER PULL OUT THE FILM BY HAND, BEFORE IT IS FULLY REWOUND. THIS MAY RESULT IN A MALFUNCTION OR DAMAGE TO THE CAMERA.)

FLASH PHOTOGRAPHY

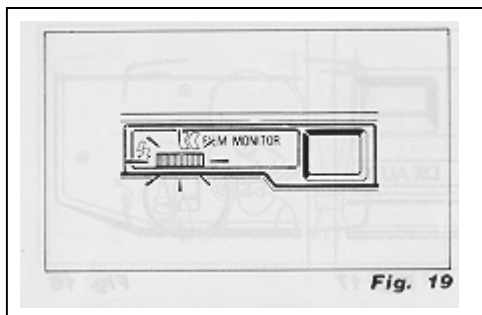

When flash is required, the Flash Unit automatically pops up into vertical position.

1. Check that the Flash Ready Lamp is lit, then take the picture. (Fig. 19)
2. When you have completed flash photography, please be sure to push the Flash Unit down. This turns off the flash.

Flash Photography Distance

Shooting Range: 1 - 4m (3.3 - 9.8 ft)

- * If the Shutter Release Button is kept pressed halfway down before the Flash Ready Lamp comes on, the Flash Unit will not be charged.
- * Be careful not to put your finger in front of the flash window.
- * If the Shutter Release Button is pressed before the Flash Ready Lamp lights up, the shutter will not release.
- * You can use the Flash Unit as a fill-in light for daytime photography too. Cover the photocell with your hand and press the Shutter Release Button in halfway. Then the Flash Unit pops up.

USING THE SELF-TIMER

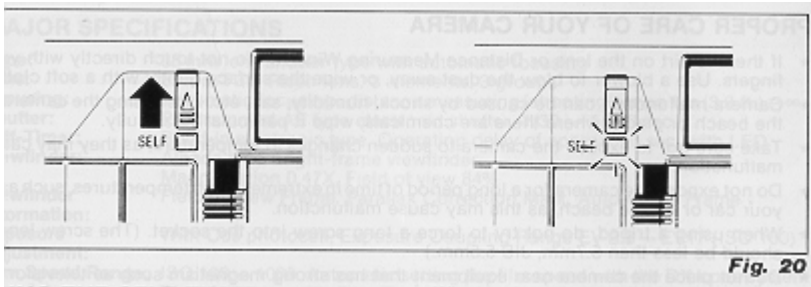

1. Slide the Self-Timer Switch fully in the direction of the arrow. Then the Self-Timer LED on the front of the camera blinks on and off. The shutter will be released about 10 seconds later. (Fig. 20)

- * If you wish to clear the self-timer once it has started, close the Lens Shield.
- * When using the self-timer with flash photography, put the Self-Timer Switch on after the Flash Ready Lamp is lit. (When the surrounding light is not sufficient, the Flash Unit pops up immediately after the Self-Timer Switch is activated.)
- * When using the self-timer with pre-focus shooting, measure the distance by pressing the Shutter Release Button halfway. Without removing your finger from the Shutter Release Button, slide the Self-Timer Switch on, and the self-timer will operate. Pre-focus will be held automatically until the picture is taken.

PROPER CARE OF YOUR CAMERA

- * If there is dirt on the lens or Distance Measuring Window, do not touch directly with your fingers. Use a blower to blow the dust away, or wipe the surface gently with a soft cloth.
- * Camera malfunction can be caused by shock, humidity, salt, etc. After using the camera at the beach or places where there are chemicals, wipe it particularly carefully.
- * Take care not to expose the camera to sudden changes in temperature, as they may cause malfunction.
- * Do not expose the camera for long period of time in extremely high temperatures, such as in your car or on the beach, as this may cause malfunction.

* When using a tripod, do not try to force a long screw into the socket. (The screw length should be less than 5.7mm, JIS 5.5mm.)

* Do not place the camera near equipment that has strong magnetism such as television or radio.

* Remove the batteries before storing the camera, and keep the camera in a place that is free of dust and humidity.

* Avoid keeping the camera in a closet, etc. where the camera may be affected by mothballs, insecticides, etc.

MAJOR SPECIFICATIONS

Type: 35 mm lens shutter type with automatic focusing

Lens: 35 mm F3.9 Ricoh lens, 3 elements, 3 groups

Focusing: Automatic focusing; distance measuring (shooting) range 1 m (3.3 ft.) - ∞

Shutter: Programmed AE type electronic shutter, 1/30--1/500 sec.

Self-Timer: Build-in electronic type. Operating delay of approx. 10 sec. with LED

Viewfinder: Albada type bright-frame viewfinder

Magnification: 0.47X, Field of view 84%

Viewfinder Information: Field of View Frame, Parallax Correction Mark, Auto Focus Frame

Exposure Adjustment: With Cds photocell, Exposure Coupling Range EV 8.8--EV17 (ISO 100)

Film Speed Range: ISO 100--1000. Automatic setting the film speed with the DX-code system

Film Advance: Electric motor with Film Transport Monitor. Automatic 1st frame setting.

Rewind: Automatic film rewind at the end of film

Film Loading: RICOH Auto-Load system

Exposure Counter: Additive, automatically resets to A when the camera back is opened

Built-in Flash: Automatic pop-up electronic flash in dim light

Guide Number: 10(ISO 100, m) Exposure adjustment through flashmatic system

Interval Between Flashes: About 7 seconds

Number of Shots Possible: With new alkaline batteries (under normal temperature of 20 degrees C) without using the flash unit: more than 70 rolls of 36 exposure film; when using the flash unit repeatedly more than 7 rolls of 36 exposure film

Power Source: 2 penlight alkaline batteries or 2 penlight manganese batteries (Nickel Cadmium batteries cannot be used).

Other Features: Flash Ready Light, Film Loaded Window,

Dimensions: 118mm(W)x66mm(H)x45mm(D)

Weight: 2359 (without batteries)

Specifications and appearance are subject to change without notice.

If you wish to rewind the film before the end of the roll is reached, rewind the film by means of the Manual Film Rewind switch on the bottom of the camera. (Use a ballpoint pen, etc. to activate rewinding). The film cannot be rewound when the back cover is open. **(Fig. 1)**

Caution: Never pull out the film by hand, before it is fully rewound. This may result in a malfunction or damage to the camera. (Fig. 2)