

Ricoh AF-7

This camera manual library is for reference and historical purposes, all rights reserved.

This page is copyright© by mike@butkus.org, M. Butkus, NJ.

This page may not be sold or distributed without the expressed permission of the producer.

I have no connection with any camera company.

On-line camera manual library.

If you find this manual useful, how about a donation of \$3 to:

M. Butkus, 29 Lake Ave., High Bridge, NJ 08829-1701

and send your e-mail address so I can thank you.

Most other places would charge you \$7.50 for a electronic copy or \$18.00 for a hard to read Xerox copy.

This will help me to continue to host this site, buy new manuals, and pay their shipping costs.

It'll make you feel better, won't it?

If you use Pay Pal, use the link below.

Use the above address for a check, M.O. or cash.



www.PayPal.me/butkus

Venmo @mike-butkus-camera Ph. 2083

[Back to main camera manual page](#)

www.butkus.us



PARTS

- | | |
|----------------------------------|---------------------------|
| 1. Viewfinder | 5. Shutter Release Button |
| 2. Distance Measuring Window | 6. Self Timer Switch |
| 3. Film Monitor/Exposure Counter | 7. Strap Eyelet |
| 4. Film Rewind Switch | 8. Photocell |

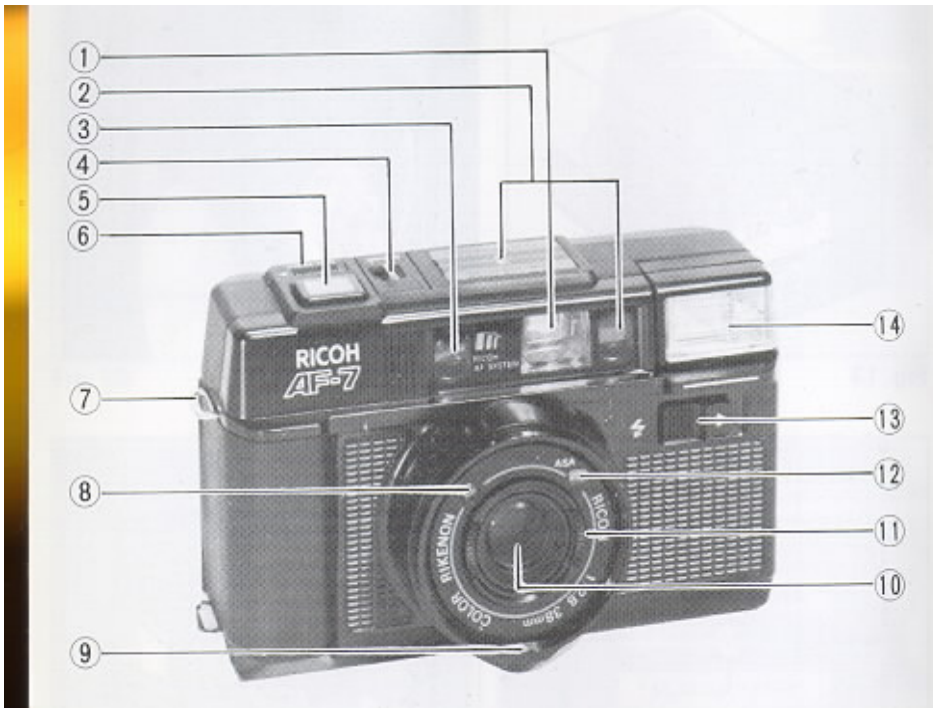

9. Shutter Release Lock Button

10.. Lens

11. Film Speed Ring

12. Film Speed Window

13. Flash Unit Switch

14. Built-in Flash Unit

15. Viewfinder Eyepiece

16. Flash Ready Lamp

17. Film Rewind Shaft

18. Film Chamber

19. Battery Compartment Cover

20. Film Guides

21. Film Rewind Release Button

22. Tripod Socket

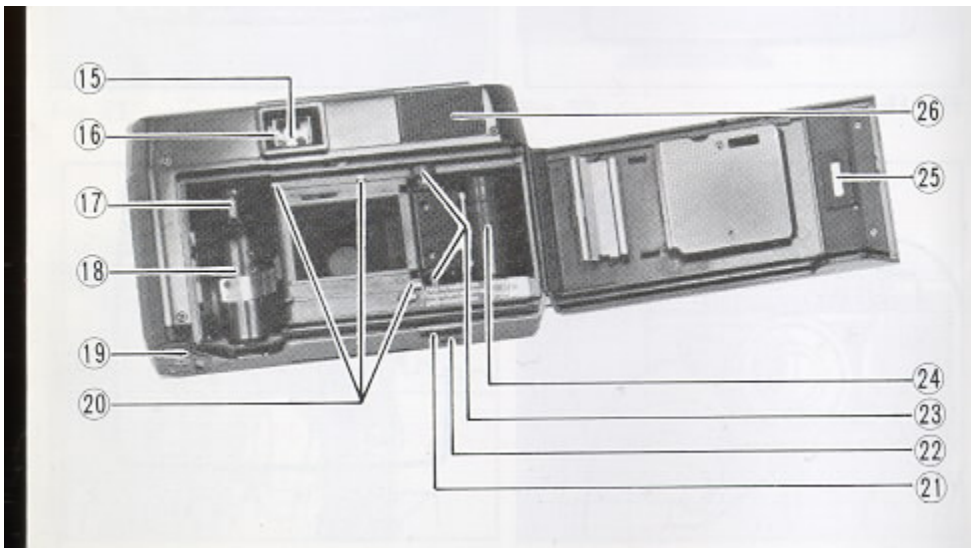

23. Sprocket

24. Film Take-up Spool

25. Film Check Window

26. Finger Rest

We are most gratified that you have selected the RICOH AF-7. All you have to do is point the camera at the subject you wish to photograph and press the shutter release button. Focusing and exposure are done automatically. In addition, film loading, advance and rewinding are also automatic, so that everyone can enjoy this easy to use camera.

Please read these instructions carefully before you use the camera.

INSERTING THE BATTERIES

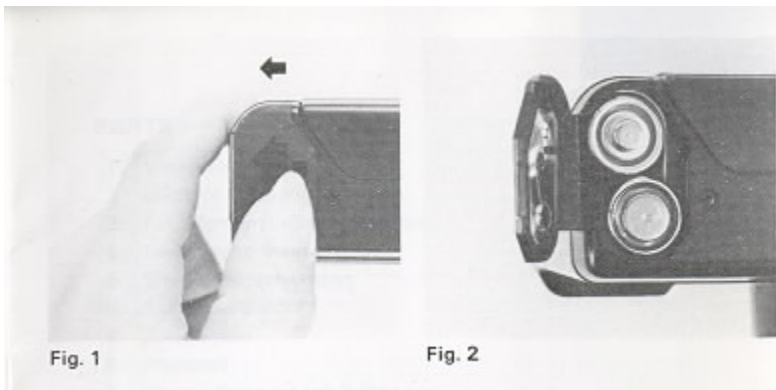

This camera will not operate unless the batteries are inserted. It is important to install the batteries properly.

1. Push the Battery Compartment Cover in the direction of the arrow <~1 to open. (Fig. 1)

2. Insert two batteries, checking that the 13 and ~ on the batteries are lined up correctly, according to the polarity diagram inside the battery compartment. (Fig. 2)

3. Close the Battery Compartment Cover by pushing it in the direction of the arrow. (Fig. 3)

Batteries to use

Two Alkaline penlight batteries or Two Manganese penlight bakeries.

- Do not use Nickel Cadmium batteries.
- Please remove the batteries from the camera when you do not use the camera for a long period of time.

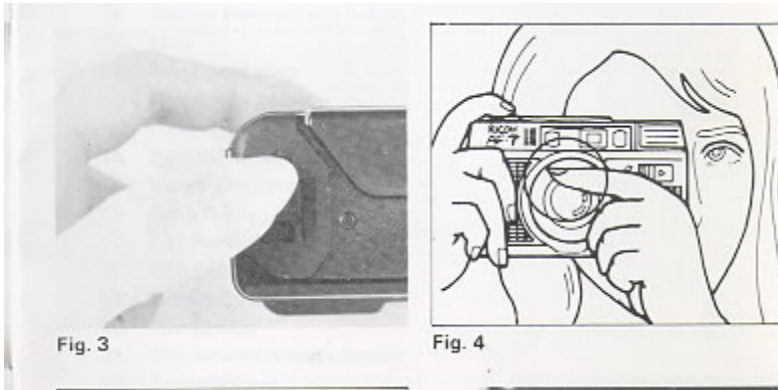

CHECKING THE BATTERIES

Remove the Lens Cap before you check the batteries. If the lens cap is led on, a safety device will operate to prevent the Shutter Release Button from being activated.

* Make sure the Shutter Release Button is not pressed in when you are removing the lens cap, as a frame may be taken in error.

1. Cover the Photocell (small glass window next lens) with your hand, and press the Shutter Release Button in halfway. (Fig. 4)

2. If the red Camera Shake Warning Signal in the Viewfinder blinks, then the batteries are in working order. (Fig. 5)

In normal temperatures (at 20 C and with new Alkaline batteries) without using the Flash Unit, approximately 70 rolls of 36 exposure film can be taken. If the Flash Unit is used for every frame, then 7 rolls of 36 exposure film can be taken. Please change both batteries to new ones of the same kind in the following cases:

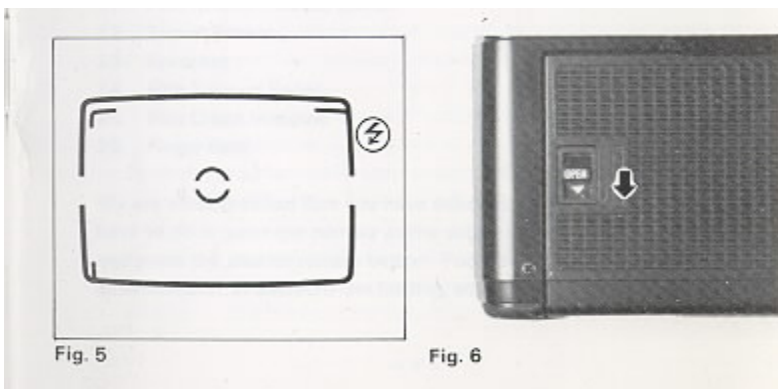

A. The red Camera Shake Warning Signal t does not blink when you have covered the Photocell with your hand and the Shutter Release Button is pressed in.

B. The shutter cannot be released (remember to remove the Lens Cap).

C. The Flash Ready Lamp takes more than 30 seconds to light up.

D. The Film Advance or Film Rewind does not operate.

E. The batteries have been in the camera for more than one year (even without using the camera, batteries will run down naturally).

· Generally, in cold conditions, the capacity of the batteries decreases, and in some cases, the camera may not operate properly. You should either warm the batteries or keep a spare set in your pocket, inserting them just before you use the camera. Incidentally, batteries that have lost their capacity in cold temperatures, will recover in normal temperatures, so do not throw them away

LOADING THE FILM

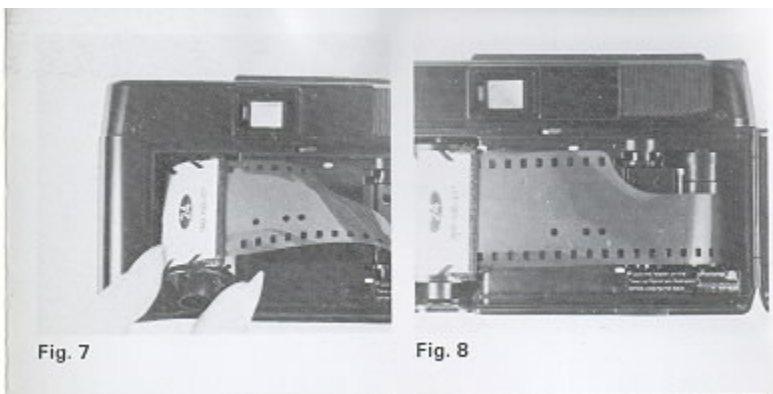

1. Push the back cover lever downwards in the direction of the arrow HI to open. (Fig.6)

2. Load the film in the Film Chamber. (Fig. 7)

3. Pull out the film leader and place it over the Film Take-up Spool. Please see that the film is within the white Film Guides. (Fig. 8) (Fig. 9) (Fig. 10)

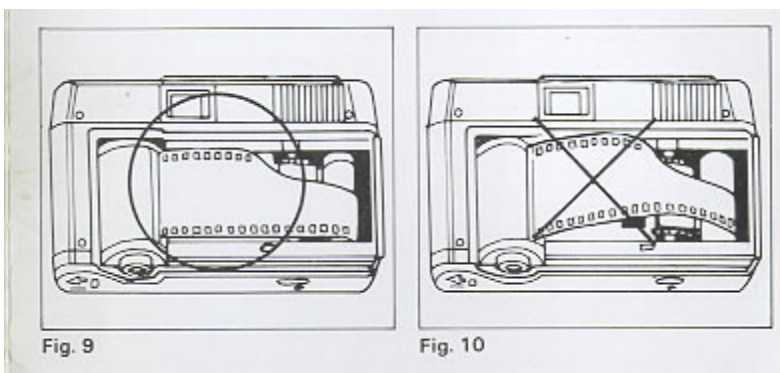

4. Push the back cover shut so that the back cover lever is back to its original position. (Fig. 11)

5. Press the Shutter Release Button to advance the film until the number '1' appears in the Exposure Counter window. If no number appears in the Exposure Counter window, the film is not loaded correctly. Please reload the film. (Fig. 12)

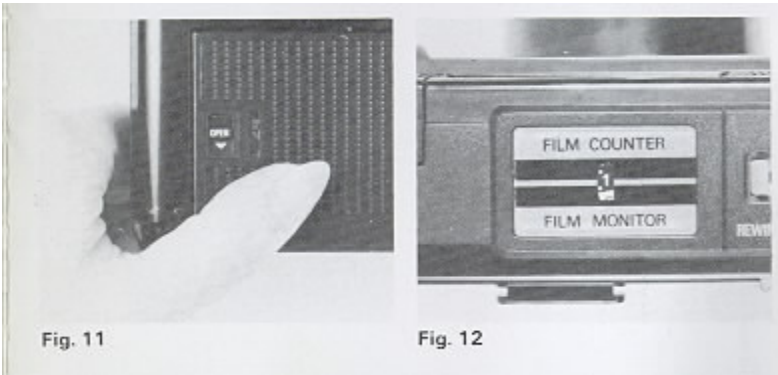

* The Film Monitor is a mechanism ensures that if the film is not advancing correctly, the Exposure Counter will not move forward.

- Always avoid direct sunlight when you load the film.
- If the film is removed from its carton and led in high temperatures or humidity before it is loaded, it may not advance to the end of the film.

SETTING THE FILM SPEED

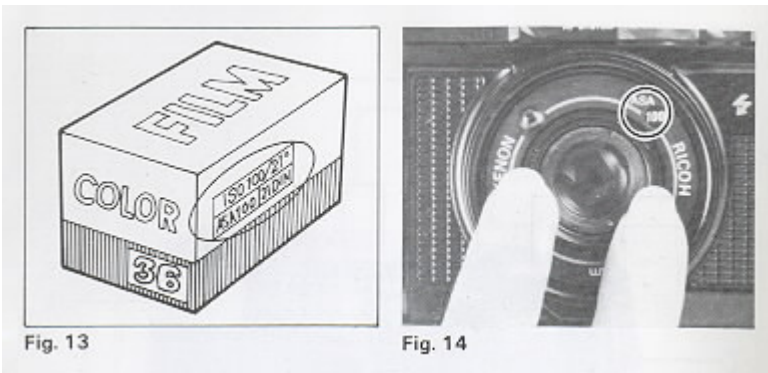

1. The film speed is indicated on the outer packaging of the film: e.g. ASA 100 (ISO 100/21) ASA 400 (ISO 400/27) (Fig. 13)

2. Turn the Film Speed Ring to set the speed of the film you are using in the center of the Film Speed window. (Fig. 14)

- Please set the Film Speed Ring to click stop positions. Do not use mid-way positions.

		<p>VIEWFINDER</p> <ol style="list-style-type: none"> 1. Field of View Frame 2. Parallax Correction Marks 3. Flash Ready Lamp 4. Auto-Focus Frame 5. Camera Shake Warning Signal (Fig. 15)
<p>Fig. 15</p>	<p>Fig. 16</p>	

1. Field of View Frame

The subject such as people or scenery that you wish to take should be set within this frame.

2. Parallax Connection Marks

When taking a picture of a subject that is between 1 ~ 1.2 m (3 - 4 A) away from the camera, it should lie within these marks. Anything outside the marks will not be included in the picture even though you can see it through the viewfinder.

3. Flash Ready Lamp

When the flash is fully charged and ready for shooting, this lamp will light up.

4. Auto-Focus Frame

The Auto-Focus Frame focuses automatically on the subject that lies within it.

5. Camera Shake Warning Signal

If this lamp blinks when the Shutter Release Button is pressed halfway, then you should change to flash photography.

SHOOTING ON AUTO-FOCUS

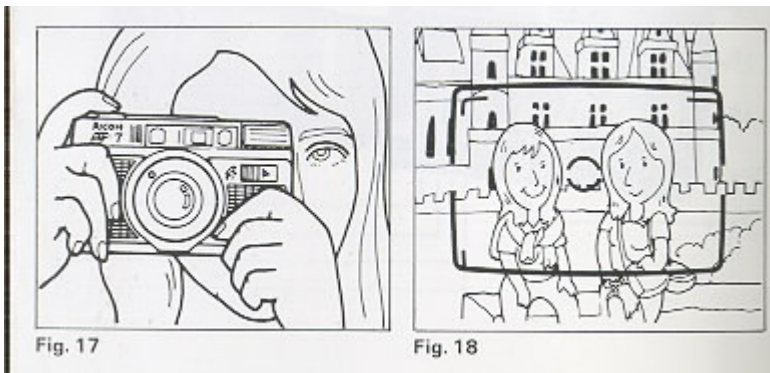

1. Set the subject you wish to take within the Auto-Focus Frame in the center of the Viewfinder. (Fig. 16)

2. If the Camera Shake Warning Signal does not light gently press the Shutter Release Button in fully to take the picture. The film will advance automatically as soon as the shutter has been released. (Fig. 1 7)

· Please be careful not to cover the Distance Measuring Window at the front of the camera accidentally, as the focusing will not be correct.

· Please keep the Distance Measuring Window clean so that the focusing is accurate. If it gets dirty, please wipe it clean with a son cloth.

· There may be rare cases where the subject cannot be properly focused.

(For instance, subjects that do not reflect light well, glossy subjects, or subjects taken through glass.)

Shooting Distance

For subjects that are less than 1 m away from the camera, it is not possible to obtain a sharp focus.

PRE-FOCUS SHOOTING

When the subject you wish to focus on is outside the Auto-Focus Frame, or if the subject is difficult to focus on, you should use the prefocus feature.

When the subjects outside the Auto-Focus Frame

1. If you want to photograph two people, there may be cases where neither of them can be set within the Auto-Focus Frame in the center of the Viewfinder. If you release the shutter, the background will be in focus, and the people which are the main subject will be out-of-focus. (Fig. 18)
2. Move the camera so that one of the people is within the Auto Focus Frame. (Fig. 19)

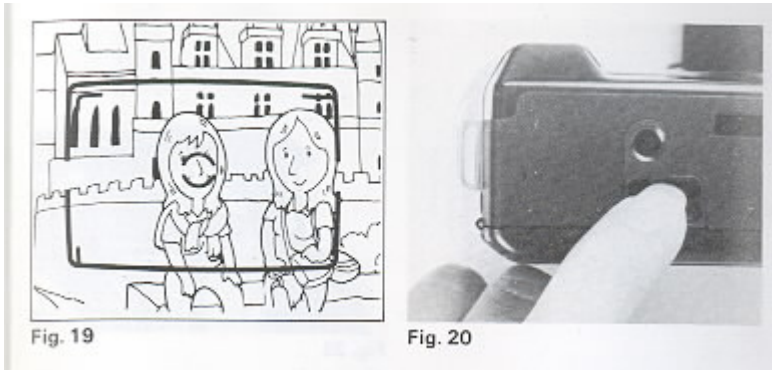

3. Press the Shutter Release Button halfway. Keep your finger pressed down on the Shutter Release Button. This will auto lock the focus on this subject.
4. Return the camera to its former position so that both people are in the Field of View Frame, then press the Shutter Release Button fully to take the picture. (Fig. 18)

When the subject is difficult to focus on

1. When you take subjects that are difficult to focus on, find another subject at about the same distance from the camera. Use that subject in the same way as described above.
- When you remove your finger from the Shutter Release Button, prefocusing will be cancelled, so you can then go on to focus again as many times as you wish.

REWINDING THE FILM

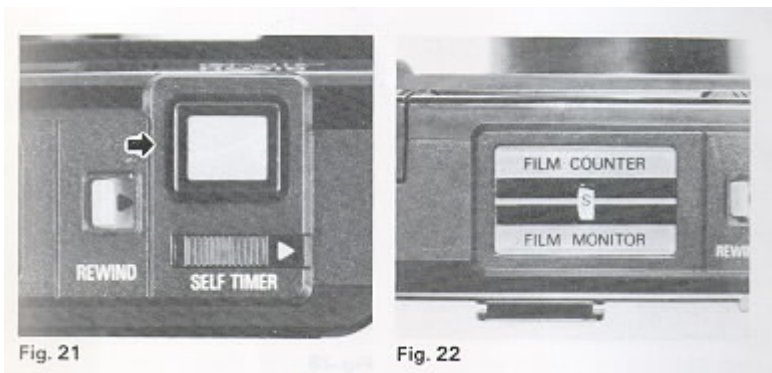

When the end of the film has been reached, an electronic sound will be emitted. Please rewind the film immediately.

1. Push the Film Rewind Release Button on the underside of the camera. (Fig. 20)
 2. Push the Film Rewind Switch on the top of the camera in the direction of the arrow. (Fig. 21)
 3. As you rewind the film, the Exposure Counter will run backwards.
 4. When the "S" appears in the Exposure Counter window, slide the Film Rewind Switch back to its former position. Film rewinding is now completed and you can unload the film. (Fig. 22)
- Do not open the back cover until the "S" has appeared in the Exposure Counter window.

FLASH PHOTOGRAPHY

Change to flash photography when the Camera Shake Warning Signal (ok) in the Viewfinder blinks when the Shutter Release Button is pressed halfway.

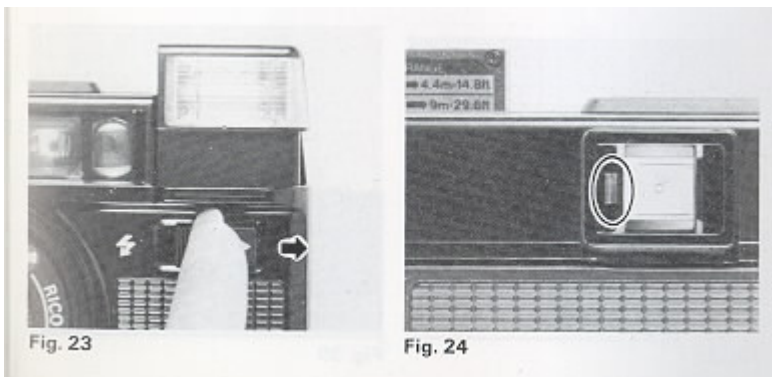

1. Push the Flash Unit Switch in the direction of the arrow ~ and the Flash Unit will pop up turning the power source on automatically. (Fig. 23)
2. Check that the Flash Ready Lamp in the Viewfinder is lit, then take the picture. (Fig. 24)

Flash photography distance

Shooting range: 1 m/3.3ft-4.3m/14.1 h(ASA100)

1 m/3.3 ft - 5.2 m/17 h (ASA400)

1.4 m/4.6 A- 5.5 m/18.2 h (ASA1000)

- Always push the Flash Unit back in when not in use. (If it is led up, the batteries will wear out faster.)
- If the Shutter Release Button is kept pressed halfway with the Flash Unit on, the Flash Unit will not be charged. Allow the flash to charge by removing your finger from the shutter release.
- Be careful not to put your finger in front of the flash window.
- If the Shutter Release Button is pressed before the Flash Ready Lamp lights up, the picture will be under-exposed.

- You can use the Flash Unit as a fill-in light for daytime photography too.

USING THE SELF-TIMER

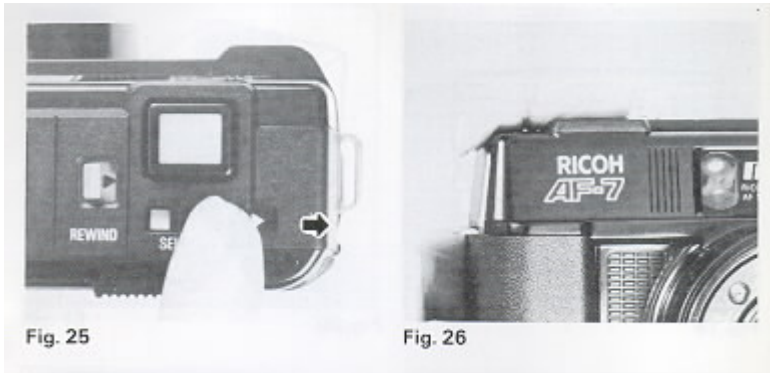

1. Slide the Self-Timer Switch fully in the direction of the arrow. (Fig. 25)
2. When the Shutter Release Button is pressed, an electronic sound will be emitted. The shutter will be released about 10 seconds later. (Fig. 26)
3. When you have finished using the Self-Timer, please slide the Self Timer Switch back to its former position. (Fig. 27)

- If you wish to cancel the Self-Timer, slide the Self-Timer Switch back to its former position.
- When using the Flash Unit together with the Self-Timer, press the Shutter Release Button only after the Flash Ready Lamp is lit.

OTHER FEATURES

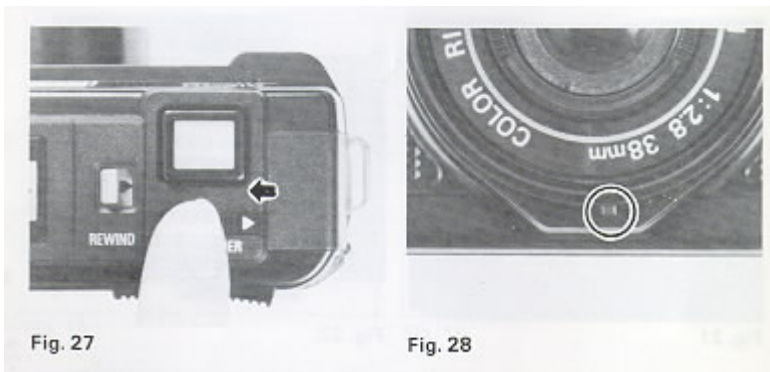

1. Shutter Release Lock
When the lens cap is put on, the shutter will be locked. This is a convenient mechanism that prevents you taking a picture with the lens cap in place, or releasing the shutter by mistake. (Fig. 28)
2. Film Check Window
You can confirm whether a film is loaded or not by looking through the Film Check Window. (Fig. 29)
3. Diopter Correction
There is a Diopter Correction Adapter to enable people who are near or far sighted to see more clearly through the viewfinder. Please use the Diopter Correction Adapter for the RICOH SLR cameras. It slides on the Viewfinder Eyepiece. (Fig. 30)

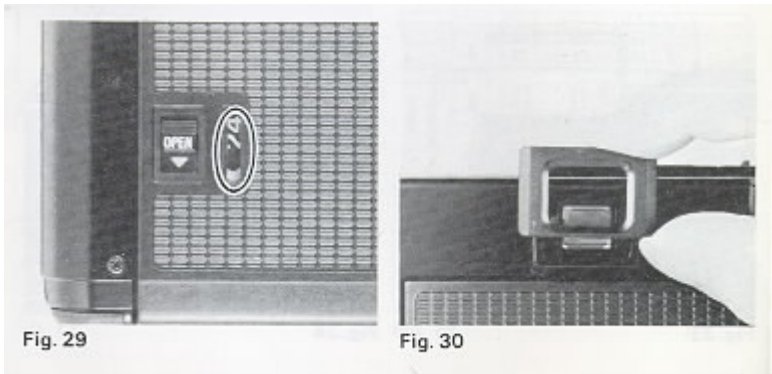

MAJOR SPECIFICATIONS

Type: 35 mm lens shutter type with automatic focusing

Lens: 38 mm F2.8 Colour Rikenon lens, 4 elements 3 groups filter diameter 46 mm

Focusing: Automatic focusing with pre-focus facility. Distance measuring (shooting) range 1 m ~ ∞

Shutter: Programmed AE type electronic shutter.

Self-timer: Built-in. Operating delay of approx. 10 secs.

Viewfinder: Albada type with bright frame viewfinder (with parallax correction marks). Magnification: 0.46 X
Field of View 83%, Diopter Correction Adapter can be attached.

Viewfinder information: Field of View Frame, Parallax Correction Marks, Auto-Focus Frame, Camera Shake
Warning Signal, Flash Ready Lamp.

Exposure Adjustment: With Cds Photocell, Exposure Coupling Range EV6 ~ EV17 (ASA 100)

Film Speed Range: ASA 25 ~ ASA 400

Film Advance/Rewind: By electric motor with Film Check Window

Film Loading: RICOH Auto-Load system

Exposure Counter: Additive, reversed when rewinding Built-in Flash:

Flash photography by turning of Flash Unit Switch Guide Number:

12 (ASA 100)m. Exposure adjustment through flash-matic system.

Interval between flashes: About 7 seconds

Number of shots possible: With new Alkaline batteries (under normal temperatures of 20 C)

Without using flash unit: more than 70 rolls of 36 exposure film.

When using the flash unit repeatedly: more than 7 rolls of 36 exposure film.

Power Source: 2 penlight Alkaline batteries or 2 penlight Manganese batteries
(Do not use Nickel Cadmium batteries)

Dimensions: 129 mm (W) x 79 mm (H) x 55 mm (D)

Weight: 330 g (without batteries)

Specifications and appearance of this camera are subject to change without notice.