

Ricoh XR-10 (KR-10X)

historical purposes, all rights reserved.

This page is copyright by mike@butkus.org, M. Butkus, NJ.

This page may not be sold or distributed without
the expressed permission of the producer
I have no connection with any camera company.

On-line camera manual library

If you find this manual useful, how about a donation of \$3 to:

M. Butkus, 29 Lake Ave., High Bridge, NJ 08829-1701

and send your e-mail address so I can thank you.

**Most other places would charge you \$7.50 for a electronic copy
or \$18.00 for a hard to read Xerox copy.**

**This will help me to continue to host this site,
buy new manuals, and pay their shipping costs.
It'll make you feel better, won't it?**

**If you use Pay Pal, use the link below.
Use the above address for a check, M.O. or cash.**



www.PayPal.me/butkus

Venmo @mike-butkus-camera

[Back to main camera manual page](#)

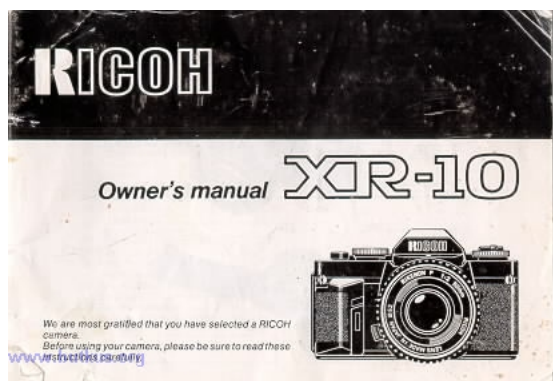

NOMENCLATURE

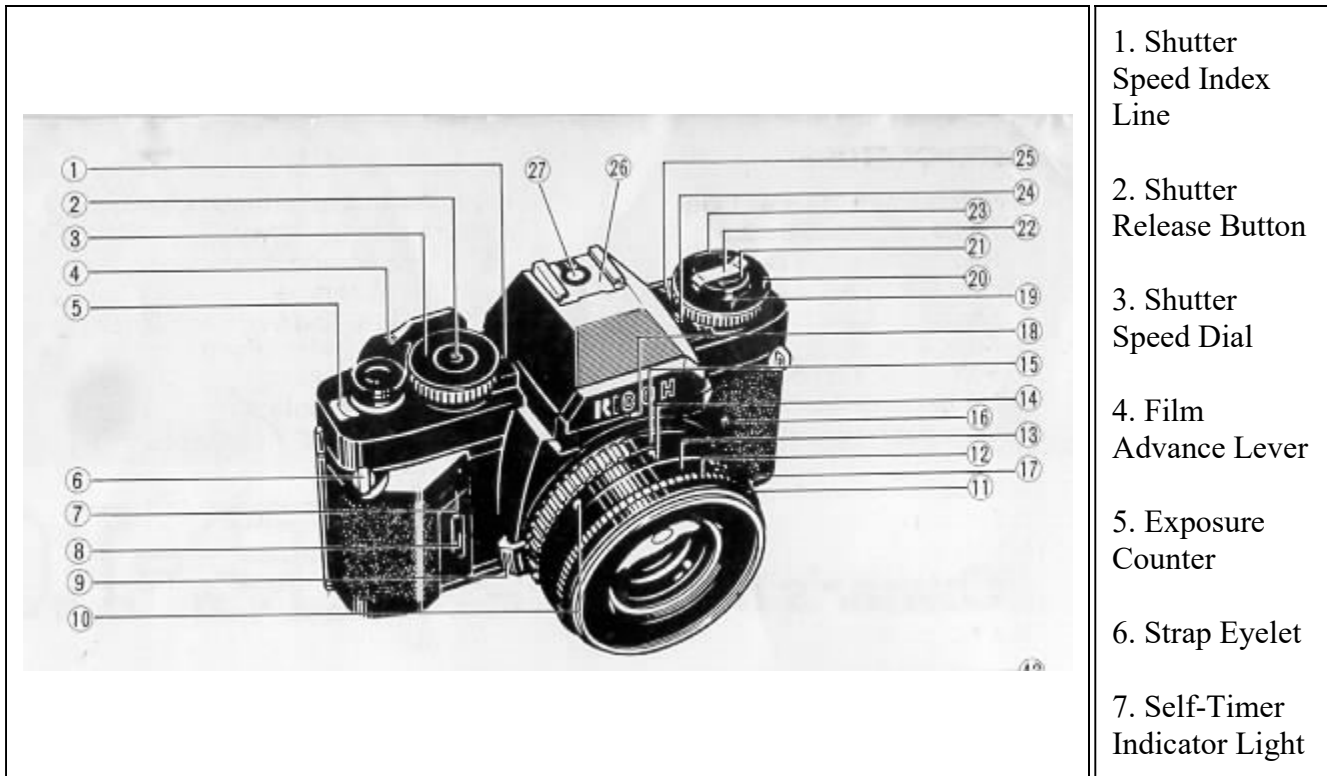

1. Shutter Speed Index Line
2. Shutter Release Button
3. Shutter Speed Dial
4. Film Advance Lever
5. Exposure Counter
6. Strap Eyelet
7. Self-Timer Indicator Light

8. Exposure Indication Switch
9. Lens Release Lever
10. Lens Locator Mounting Node
11. Flash Synchro Terminal
12. Focusing Ring
13. Distance Scale
14. Depth of Field Scale
15. F-Stop Ring

16. AE Lock Button
17. P Lock Button
18. Aperture Relay Port
19. Film Speed Index Line
20. Film Speed Dial
21. Film Rewind Knob

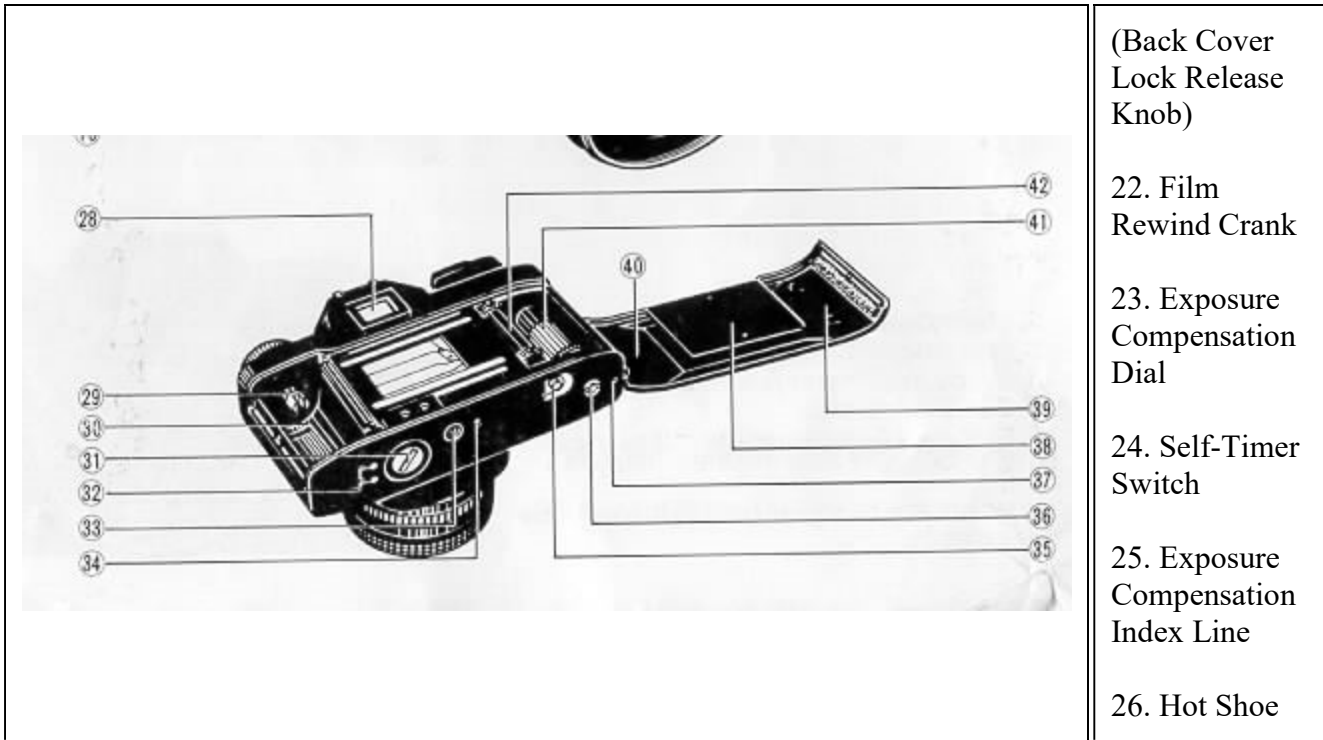

- (Back Cover Lock Release Knob)
- 22. Film Rewind Crank
- 23. Exposure Compensation Dial
- 24. Self-Timer Switch
- 25. Exposure Compensation Index Line
- 26. Hot Shoe

<ul style="list-style-type: none"> 27. Flash Ready Signal Contact 28. Viewfinder Eyepiece 29. Film Rewind Shaft 30. Film Chamber 31. Battery Compartment Cover 32. PG-4 Contact Point 33. Tripod Socket 34. Winder Contact 	<ul style="list-style-type: none"> 35. Film Rewind Release Button 36. Winder Coupler 37. Winder Positioning Hole 38. Film Pressure Plate 39. Back Cover 40. ASA/DIN Conversion Table 41. Film Take-up Spool 42. Sprocket
--	--

CONTENTS

Attaching the Viewfinder Cap and Strap 3	
Changing Lenses4	
Inserting the Batteries 5	
Inserting the Film 7	
Setting the Film Speed 9	
Exposure Indication Switch 9	
Viewfinder Information10	
AE (Automatic Exposure) Photography 12	
F-Stop Reference Table13	
Manual Photography 14	
Shutter Speed Reference Table 14	
Holding the Camera 15	
	Focusing16
	Rewinding the Film ~ 17
	AE Lock System18
	Exposure Adjustment System 19
	B (Bulb) Setting 20
	Flash Photography (1) 21
	Flash Photography (2) 22
	Self-Timer Photography and Usage of the Viewfinder Cap 23
	Depth of Field24
	Infrared Photography 25
	Special Accessories 26
	Proper Care of Your Camera 29
	Specifications 30

ATTACHING THE VIEWFINDER CAP AND STRAP

Viewfinder Cap For instructions on how to use the Viewfinder Cap, read the section on Self-Timer Photography and Usage of the Viewfinder Cap. (Fig. 1)

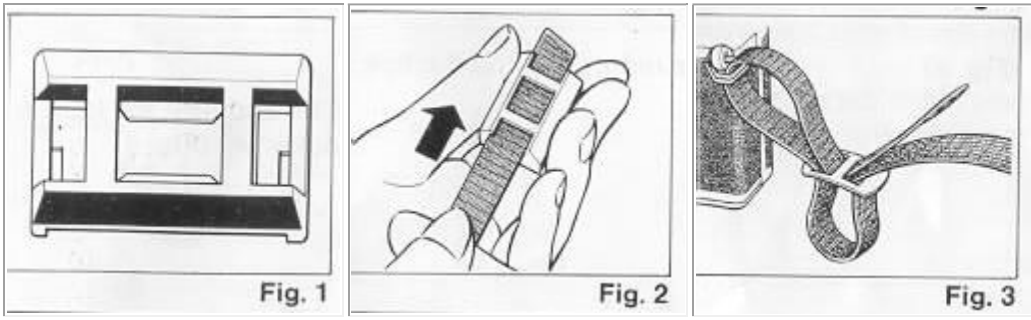

1. Slip the Viewfinder Cap on **to the Strap**. (Fig. 2)
2. Put the Strap Eyelet and adjust it to the correct length. (Fig. 3)

CHANGING LENSES

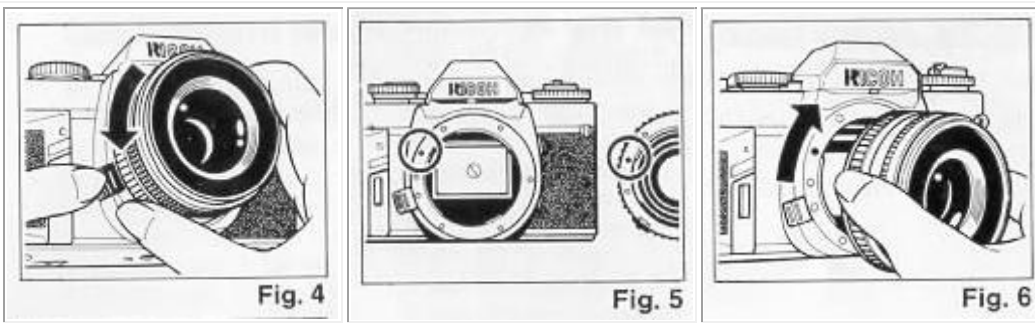

To remove the lens from the camera

1. Keep the Lens Release Lever pressed in, and turn the lens in the direction of the arrow. (counterclockwise) (Fig. 4)

To mount the lens on the camera

1. Align the red dot on the lens with the red dot on the camera. (Fig. 5)
2. When the lens has engaged, turn it in the direction of the arrow until it clicks into place. (clockwise) (Fig. 6)

* For convenience when mounting the lens in the dark, you can line up the Lens Locator Node with the Lens Release Lever.

INSERTING THE BATTERIES

The exposure meter and shutter of this camera are powered by batteries, so it is important to insert the batteries correctly for correct operation.

1. Remove the Battery Compartment Cover by turning it counterclockwise with a coin. (Fig. 7)
2. Place two batteries in the battery holder of the Battery Compartment Cover according to (+) and (-) shown outside the holder. (Fig. 8)

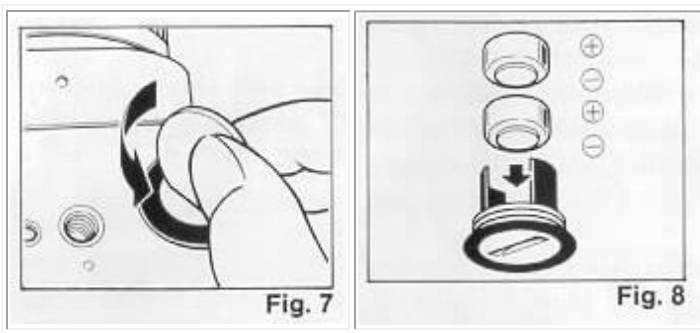

Batteries for use

Two LR-44 Alkaline batteries; life-span about 6 months under normal use.

Two SR-44 Silver Oxide batteries; life-span about 12 months under normal use. (Mallory MS76. Eveready S76 or equivalent)

One CR-1/3N 3V Lithium battery

* Since dirt or skin oils on the batteries may cause a bad contact, wipe the batteries clean with a dry cloth before inserting them.

* When your camera is not used for a long period of time, remove the batteries.

WARNING

Keep batteries out of the reach of babies and small children!

If a battery is swallowed, IMMEDIATELY contact a Doctor, as the battery material is harmful to the body!

* Generally, in cold conditions, the voltage of the batteries decreases and this will impair the functioning of the shutter and exposure meter. In these cases, either warm up the batteries or keep a spare set of batteries warm in your pocket ready to insert just before shooting.

* If no batteries are inserted, if they are incorrectly inserted, or if they are worn out, the camera will not operate. If the camera

* will not operate, check that the batteries are installed correctly. If they are, the batteries are probably dead. Replace them with new batteries.

* When the voltage of the batteries is getting low, the BAT (Battery Low Warning Signal) in the Viewfinder will blink on and off. Please change the batteries without delay.

INSERTING THE FILM

(Always avoid direct sunlight when inserting the film.)

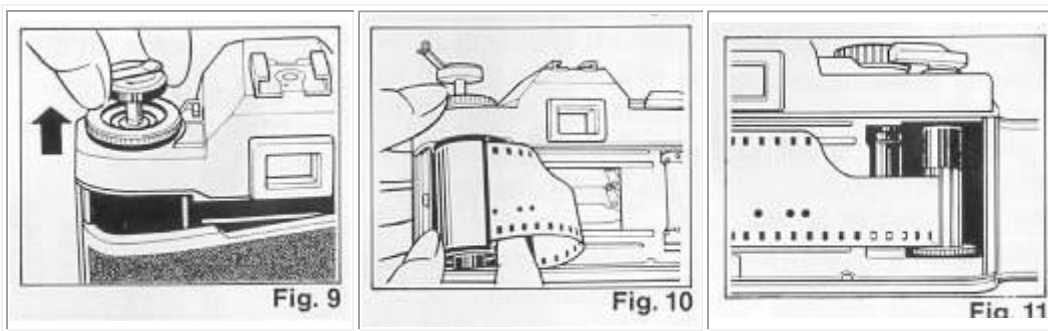

1. Pull up the Film Rewind Knob until the Back Cover snaps open. (Fig. 9)
2. Insert the film in the Film Chamber and push the Film Rewind Knob down to its former position. (Fig. 10)
You may have to rotate the knob slightly to push it down completely.
3. Insert the film leader into the slit on the Film Take-up Spool. (Fig. 11)
4. Advance the film, making sure that the sprocket holes on the film are fully engaged on the Sprocket Teeth. (Fig. 12)
5. Close and press the Back Cover firmly to lock it. Unfold the Film Rewind Crank and turn it gently in the direction of the arrow until the possible slack in the film has been taken up. (Fig. 13)
6. Advance the film and press the Shutter Release Button 2 ~ 3 times until the number "1" appears in the Exposure Counter. (Fig. 14)

As you advance the Film Advance Lever, the Film Rewind Knob rotates indicating that the film is properly advancing.

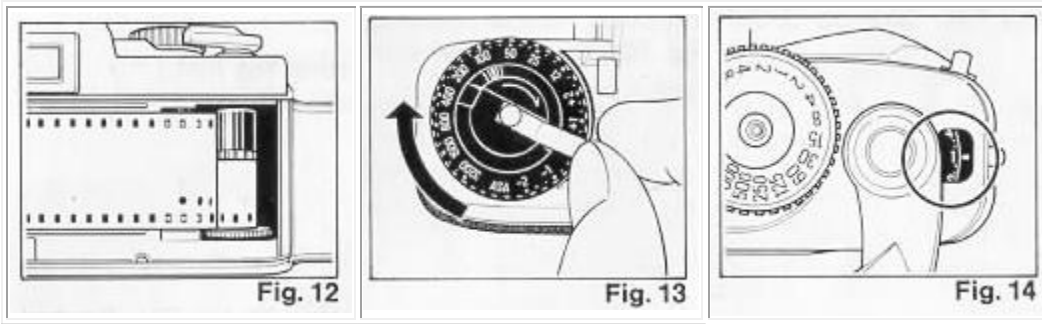

* When inserting the film, it is more convenient to set the Shutter Speed Dial to a high speed rather than A (Auto) while advancing the film to the number 1 position, to avoid a slow shutter speed (the slowest is 16 seconds). When you are ready for shooting, be sure to set the Shutter Speed Dial back to A (Auto).

* When inserting the film in cold conditions, the Film Leader may become hard and brittle. Keep the leader warm in your hand before insertion.

SETTING THE FILM SPEED

The film speed is the basic element for determining the exposure, so please be sure to set the film speed correctly. The film speed or ASA/DIN is listed on the film box.

1. Pull the Film Speed Indicator outer ring up, and set it against the film speed number you are using. (Fig. 15)

For example, if the film speed is ASA 100, set the indicator on the Film Speed Dial to 100.

EXPOSURE INDICATION SWITCH

The Liquid Crystal Display such as Shutter Speed Indicator etc. appears in the Viewfinder either by pressing Exposure Indication Switch or by releasing the shutter. After shooting, the power source will cut off automatically after 8 minutes in order to preserve the life of the batteries. (Fig. 16)

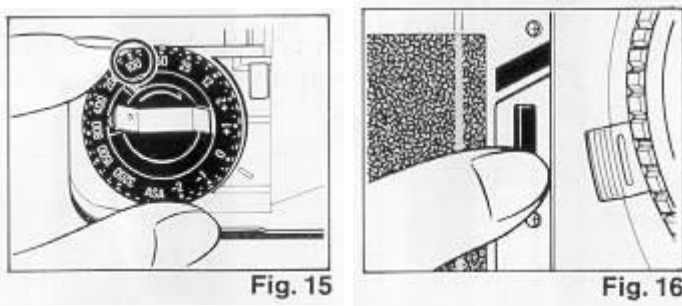

VIEWFINDER INFORMATION

1. Split-image Spot
2. F-Stop Number

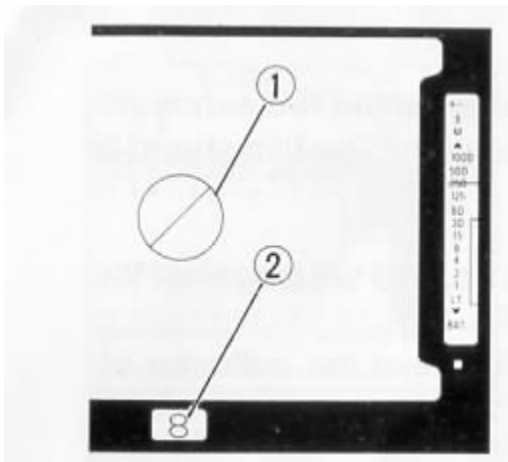

3. Shutter Speeds
4. Exposure Adjustment

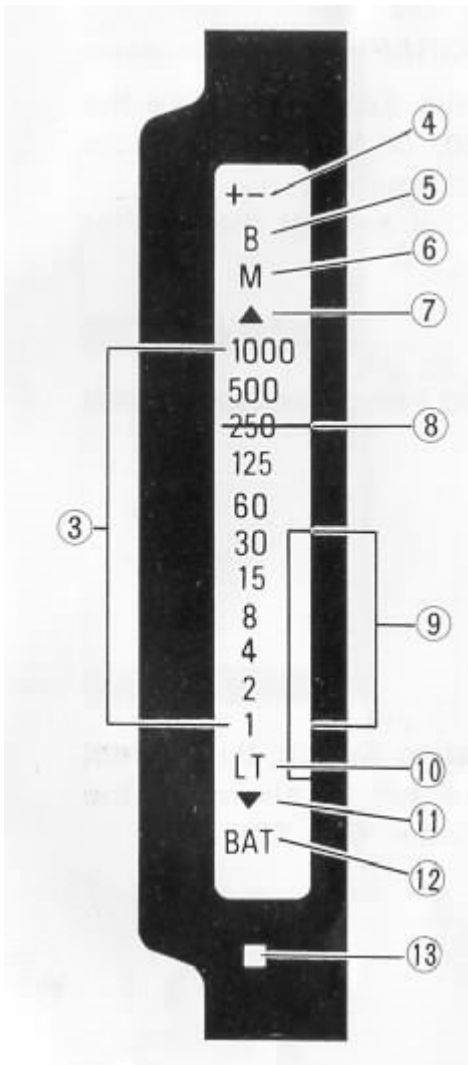

5. Bulb
6. Manual
7. Overexposure
8. Shutter Speed Indicator
9. Slow Shutter
10. Long Time Exposure
11. Underexposure
12. Battery Low Warning Signal
13. Flash Ready LED Light

The Shutter Speed, Slow Shutter and Long Time Exposure indications are always present in the Viewfinder. The information shown by the activated (Meter-ON) liquid crystal relates to exposure data for the existing lighting conditions.

* In cold conditions the response speed of the liquid crystal may get slower. This is due to the nature of the liquid crystal, and not to any camera malfunction.

* When using a polarizing filter, depending on the angle of rotation, there may be cases in which you cannot see the liquid crystal indicators.

AE (AUTOMATIC EXPOSURE) PHOTOGRAPHY

Your XR-10 enables you to use automatic exposure where the shutter speed is automatically selected, or manual exposure where you may select the shutter speed yourself. 1. Set the "A" on the Shutter Speed Dial against the Shutter Speed Index Line. (Fig. 17)

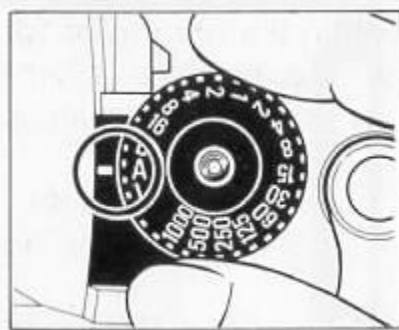

Fig. 17

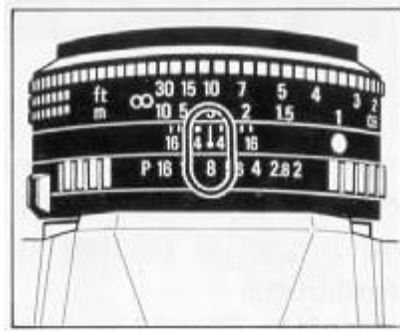

Fig. 18

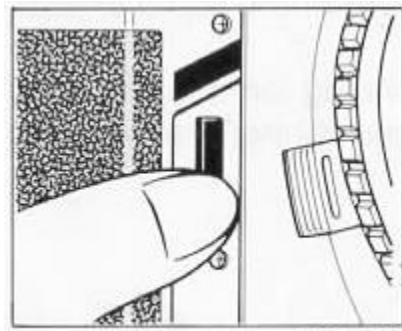

Fig. 19

2. Use the F-Stop Ring to set the desired f-stop number against the Index Line. (Fig. 18)

3. When you press the Exposure Indication Switch, the correct shutter speed for automatic exposure, will be shown by the Shutter Speed Indicator in the Viewfinder. (Fig. 19)

4. When the Shutter Speed Indicator is within the orange band, this means a slow shutter speed. You should either select a different f-stop setting, or pay particular attention to camera shake. (Fig. 20)

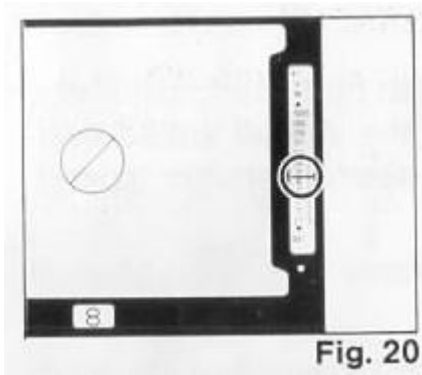

Fig. 20

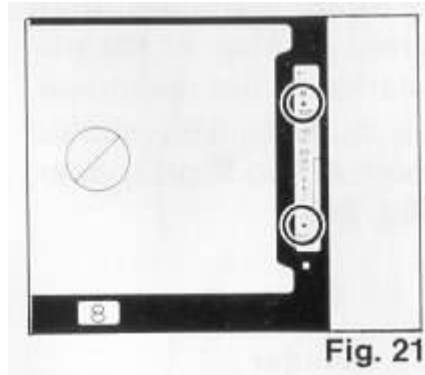

Fig. 21

5. When the ~ Overexposure mark or the ~ Underexposure mark appears, you should select another f-stop number, as the exposure is incorrect. (Fig. 21)

* You can release the shutter without pressing the Exposure Indication Switch, if you don't have to confirm the exposure information before releasing the shutter.

F-STOP REFERENCE TABLE

Lighting Conditions	F-stop Number
Indoors	f/2, 2.8
Outdoors, cloudy	f/4, 5.6
Outdoors, sunshine	f/8, 11
Beach in mid-summer and snow-scenes	f/11, 16

* With film speed ASA 100

MANUAL PHOTOGRAPHY

Manual shutter speed is precisely controlled by a quartz oscillator, the most accurate method of controlling the shutter speed ever.

1. Set the Shufler Speed Dial to the desired shutter speed. (Fig. 22)

2. The letter "M" in the Viewfinder will pulsate to indicate Manual mode. (Fig. 23)

3. If the ^ Overexposure mark or the ∨ Underexposure mark pulsates, you should select another f-stop number as the exposure is incorrect. If the ^ or the ∨ marks do not disappear, even after selecting a different f-stop number, you should select a different shutter speed. When both ^ and ∨ disappear, the exposure is correctly adjusted. (Fig. 24)

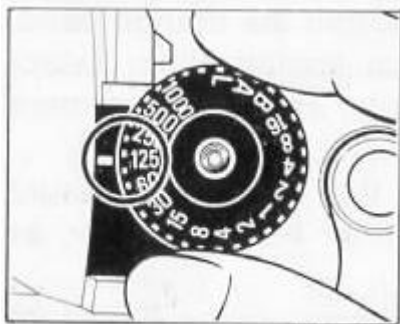

Fig. 22

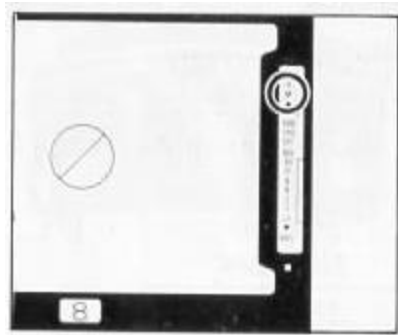

Fig. 23

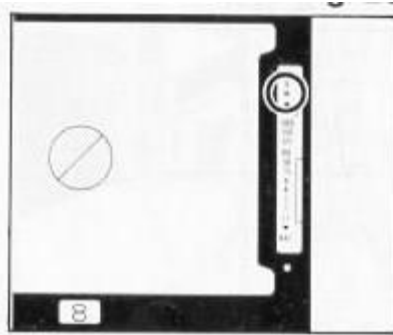

Fig. 24

SHUTTER SPEED REFERENCE TABLE

Lighting Conditions	Shutter Speed
Indoors	1 /30,1 /60
Outdoors, cloudy	1/60,1/125
Outdoors, sunshine	1 /125, 1/250
Beach In mid-summer, snow scenes	1/250, 1/1000

HOLDING THE CAMERA

Holding the camera correctly when shooting is very important. (Fig. 25)



Fig. 25

1. The camera should be positioned on the palm of your left hand so that you can use your fingers to turn the Focusing Ring of the lens easily.
2. This index finger of your right hand should rest lightly on the Shutter Release Button, while your right hand holds the camera body lightly.

3. Your right arm should be in a comfortable position.

4. Keep your left arm resting lightly against your body, and the camera should just touch your forehead when you look through the Viewfinder

* It is important to shoot with the correct body posture, to avoid blurred or tilted shots.

FOCUSING

Look through the Viewfinder to compose your picture and focus by turning the Focusing Ring. You can focus by using the center Split-image Spot. (Figs. 26, 27)

Split-image Focusing When the split image in the Split-image Spot forms a single image, the subject is in focus.

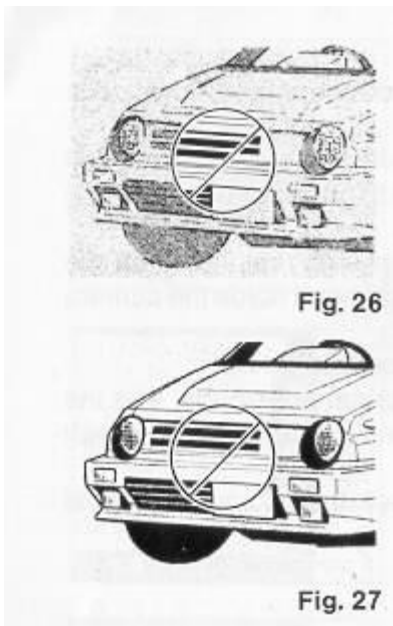

REWINDING THE FILM

(Always avoid direct sunlight when unloading the film).

After the last picture on the roll of film has been taken, rewind the film.

1. Push-in the Film Rewind Release Button on the bottom of the camera, and it will remain locked into position. (Fig. 28)

2. Unfold the Film Rewind Crank and turn it in the direction of the arrow. When the film has been completely rewound, the tension of the Film Rewind Crank is released and it will revolve freely. (Fig. 29)

3. Pull up the Film Rewind Knob to its fullest extent and the Back Cover will open. (Fig. 30) Remove the film, push the Film Rewind Knob back into position and close the Back Cover.

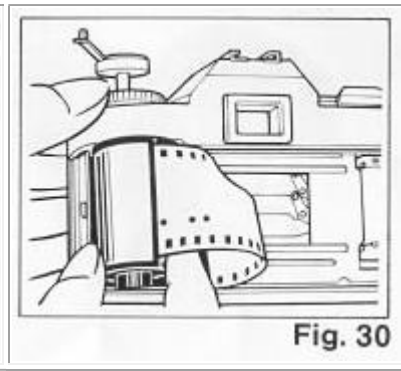
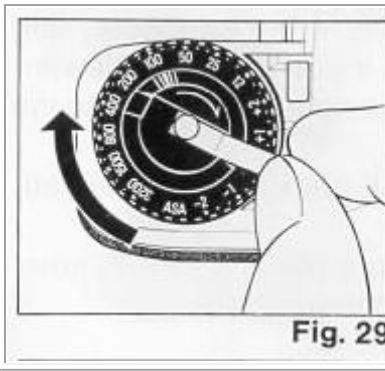
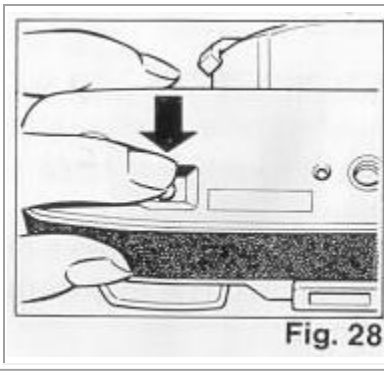

* Never open the Back Cover during rewinding, as light will get in and ruin your film.

* If you wind the film beyond the set number of frames the Film Wind Lever sometimes gets stuck midway and the Film Rewind Release Button cannot be locked in the down position. If this should happen, rewind the film by keeping the Film Rewind Release Button pressed down with your finger.

AE LOCK SYSTEM

This camera has an AE Lock system. When shooting against the light on automatic exposure, the difference in the brightness of the background and the subject means that you cannot obtain a correct exposure of the subject. In this case, you should use the AE Lock which retains the exposure of the subject regardless of the changes in the background lighting conditions. The exposure will not change until you cancel the AE Lock.

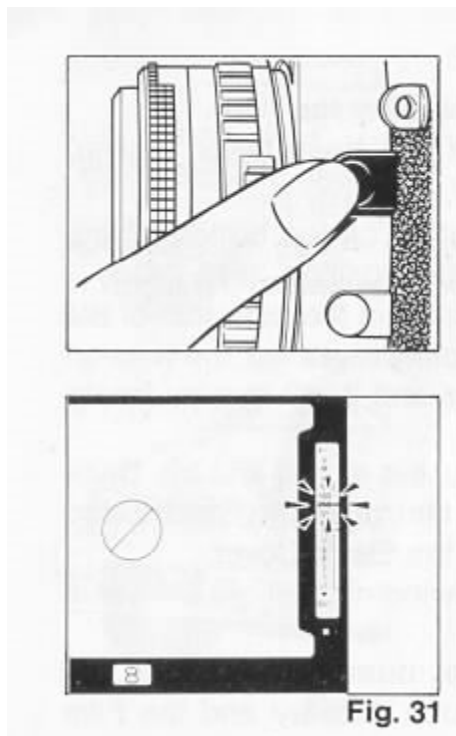

1. Move up close to the subject to measure the exposure, and press the AE Lock. The Shutter Speed Indicator in the Viewfinder will pulsate to indicate that the exposure is locked onto the object. (Fig. 31)

2. Compose the picture and shoot. The AE Lock is then automatically cancelled.

3. If you wish to cancel the AE Lock before pressing the Shutter Release Button, press the AE Lock Button again.

EXPOSURE ADJUSTMENT SYSTEM

According to shooting conditions, the camera may be affected more by the background light than the light of the subject itself. This will result in under (or over) exposed pictures. In these cases, you should use the Exposure Adjustment system. You can also use the system when you wish to create a deliberate effect of over (or under) exposure. 1. Turn the Film Exposure Compensation Dial to set the required number against the Exposure Compensation Index Line. Fig. 32)

Subject	Exposure
Scenery with a lot of sky Figure against the light	+1 to +2
Figure with a snowscape or seascape background	+1
Spot-lighted figure	-1 ~ -2



- * The Exposure Compensation Dial can be set to click stop positions (1/3 steps) between the numbers indicated.
- * Be sure to set it back to the 0 position after use.

B (BULB) SETTING

The B setting is used for shooting night scenes or long time exposures.

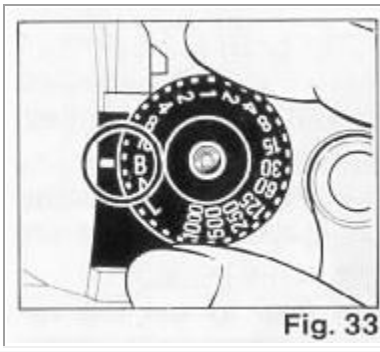

Fig. 33

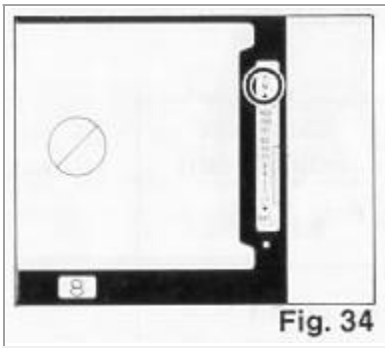

Fig. 34

1. Set the "B" against the Shutter Speed Index Line. The "B" mark in the Viewfinder will be static on display to indicate that the shutter speed is set to B (bulb). (Figs. 33, 34)

2. When you press the Shutter Release Button, the shutter will remain open as long as the button is pressed.

* For long time exposures, use a tripod and cable release to prevent camera shake.

Shutter Lock

Set "L" against the Shutter Speed Index Line to Lock the shutter when the camera is not in use. this prevents accidental shutter releasing. (Fig, 35)

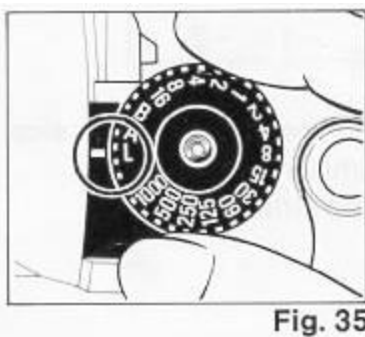

Fig. 35

FLASH PHOTOGRAPHY (1)

The RICOH SPEEDLITE 300P, 260P and 200 provide dedicated operation with the RICOH XR-10.

With these flash units, you can leave the shutter speed set on "A". Also the Flash Ready Indicator conveniently lights up in the Viewfinder, so that you don't have to take your eye away from the Viewfinder to see that the flash has recycled.

<With the SPEEDLITE 300P, 260P and 200 Flash Units

1. Attach the flash unit to the camera Hot Shoe. (Fig. 36)

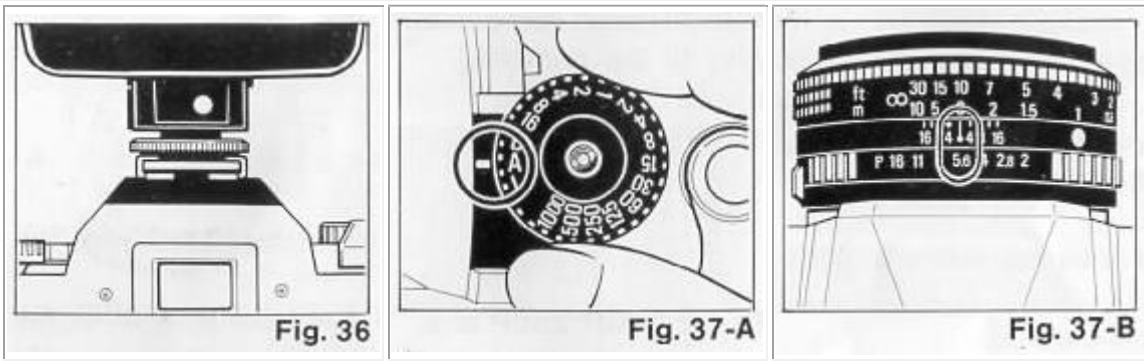

2. Set the flash unit A/M (Auto/Manual) selector to A and turn the power ON-OFF switch on.

3. Set the f-stop number to the designated exposure for automatic shooting. The flash unit will automatically control the amount of light for subjects within the distance range for automatic flash photography. (Figs. 37-A, 37-B)

4. When fully charged, the Flash Ready Indicator (RED LED) lights up in the Viewfinder, and the Shutter Speed Indicator will show 1/125 sec. (Fig. 38)

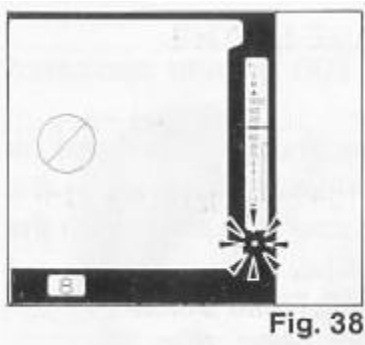

5. Now you can shoot. (If you don't see an overexposure ^ mark.)

* For further details, please refer to the instructions with the flash unit.

* Do not use other makes of flash units that have special signal pins exclusively for their cameras, as this will result in incorrect exposure and may damage the circuitry of the camera.

* If the Shutter Release Button is pressed before the Flash Ready Indicator lights up, the shutter speed will be the one indicated by the Shutter Speed Indicator.

FLASH PHOTOGRAPHY (2)

<With Flash Units Other Than the SPEEDLITE 300P, 260P and 200

1. Set the Shutter Speed Dial to the synchronizing speed of 1/125 sec. or slower shutter speeds. (Fig. 39)

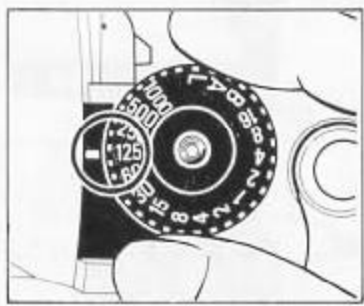

Fig. 39

* It is convenient to use the quick reference table on MANUAL flash units, which shows the recommended f-stop numbers for specific distances.

* When using other flash units, please follow the instructions with that flash units.

SELF-TIMER PHOTOGRAPHY AND USAGE OF THE VIEWFINDER CAP

The self-timer enables you to include yourself in your own photo graphs for commemorative occasions etc.

1. After advancing the film, press the Self-Timer Switch (Fig. 40)

2. The Self-Timer Indicator Light will pulsate and 10 seconds later, the shutter will be released. (Fig. 41)

3. If you wish to cancel the self-timer once it has started operating, press the Self-Timer Switch again.

* If the film has not been advanced, the self-timer will not operate.

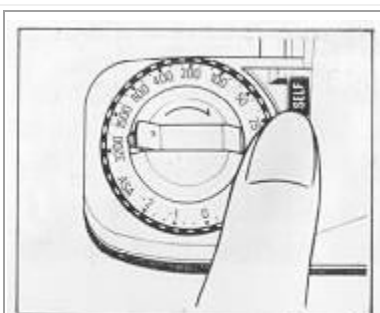

Fig. 40

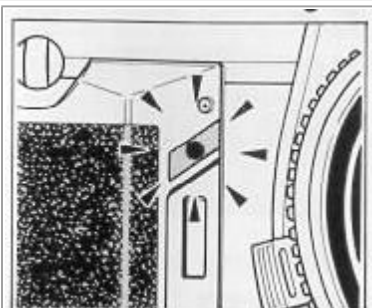

Fig. 41

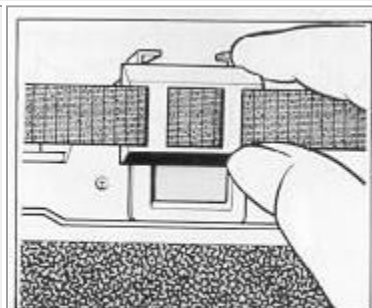

Fig. 42

Viewfinder Cap When using the self-timer with the A (Auto) setting, to prevent light from entering the Viewfinder Eyepiece and causing incorrect exposure, use the Viewfinder Cap attached to the strap to cover the Viewfinder Eyepiece. (Fig. 42)

DEPTH OF FIELD (GENERAL GUIDE LINES)

When you focus on a specific subject, often subjects in the near foreground and in the distance are also in focus. The region of good focus has some measurable depth, or "depth of field" as shown here.

1. Focus depth in the near foreground is narrow and deeper with distance.
2. Greater depth of field is obtained with smaller lens opening and a wider range of good focus is provided.
3. A lens of shorter focal length (wider angle) produces a greater depth of field. A greater depth is obtained with a wide angle lens (E.G. 28 mm) and a smaller depth is obtained with a telephoto lens (E.G. 135 mm).

The depth of field can be checked in the following way

1. A depth of field indicator is engraved on every lens. When a 50 mm standard lens is set to f-16 and focused at a distance of 3 meters, the depth of field indicator is the scale of numbers on each side of 1 mark, ranging from 16 to 16 (about 2 m to 8 m). Subjects in this distance range will be in good focus. (Fig. 43)

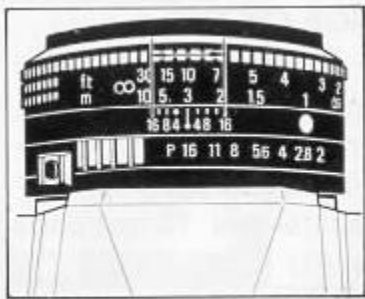

Fig. 43

INFRARED PHOTOGRAPHY

The infrared index mark is an index to correct the focusing point when you use infrared film and red filters. Since infrared light rays have a longer wave-length than visible light rays, after focusing normally on the subject, you have to adjust focus by setting that distance against the infrared index mark.

Taking Infrared Photographs

1. Attach the red filter, and focus on the subject.
2. Shift that distance to the infrared index mark. According to the instructions enclosed with the film, set the f-stop and release the shutter. (Figs. 44, 45) They still make IR film (2022). But really, there are point and shoot Digital Cameras available.

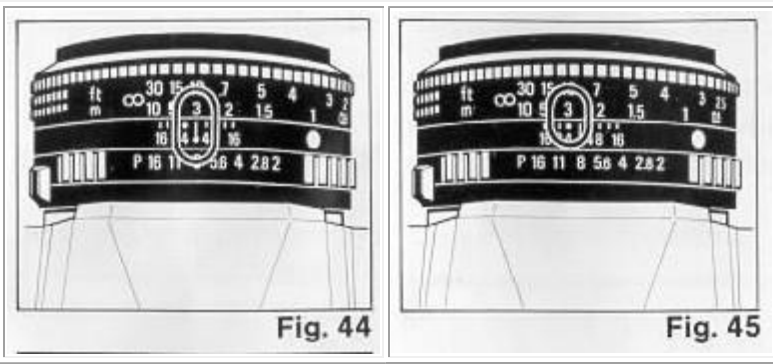

* Infrared light rays are invisible to the eye and the light meter, so please refer to the instructions with the film for setting the f-stop numbers.

SPECIAL ACCESSORIES - XR WINDER 2 (Fig. 46)

If you attach the RICOH XR WINDER 2 to this camera, the film can be advanced automatically. You can also take continuous shots at up to 2 frames per second.

* Before attaching the winder, wipe the contact points on both the camera and the winder with a dry cloth.

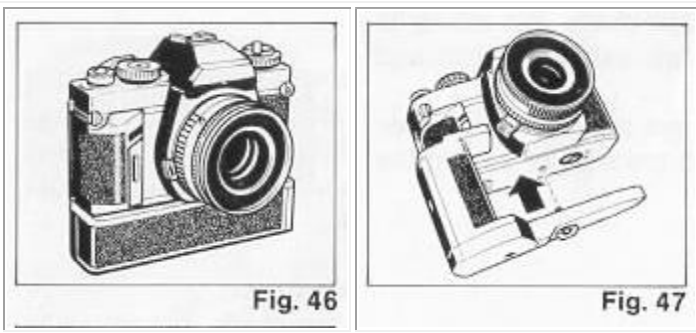

PG-4 (Power Grip) (Fig. 47)

Besides the XR Winder-2, this camera can be attached to the PG-4 power grip. With the PG-4, automatic film advance (1.4 frames/sec) is possible while taking pictures. To attach the PG-4, refer to its instruction manual.

<<< update - I have been told a Olympus eyecup will work on XR cameras >>>

XR DATA BACK II

The RICOH XR DATA BACK II enables you to take family souvenir photos, study and business record pictures, etc. together with the day, month, year or time (hours, minutes and seconds) as well as sports record films with times. Furthermore, the XR DATA BACK II can be used as a calendar or a watch through the LCD monitor. In addition, this DATA BACK II has an LSI incorporated to automatically correct for a leap year, 31-day month and month with thirty or less days up to 1999. (Fig. 48)

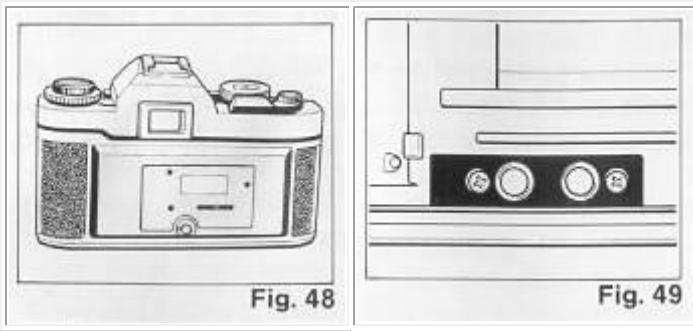

As the XR DATA BACK 11 is directly connected to the camera through the direct contact points, do not use the data cord. (Fig. 49) If the data cord is used, the film is doubly exposed.

USING A P-MOUNT ADAPTOR

If you wish to use P-mount type lenses (thread mount), use the optional P-Mount Adaptor to enable you to use many thread mount lenses. In this case, the exposure metering system will become a stopped down metering type. (Fig. 50)

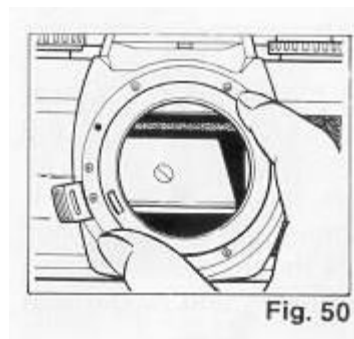

PROPER CARE OF YOUR CAMERA

- * Never touch the surface of the lens with your fingers. If the lens is dirty, either use a blower to blow the dust away or wipe it gently with a soft cloth.
- * Camera malfunction can be caused by shock, humidity, salt air, etc. After using the camera at the beach or in places that use chemicals, wipe it particularly carefully.
- * Do not use chemically-treated dusters to clean the camera.
- * Take care not to expose your camera to sudden changes in temperature, as this may cause camera malfunction.
- * Do not expose your camera for a long period of time in extremely high temperatures, such as in the back of your car or on a beach, as this may cause camera malfunction.
- * When using a tripod, do not try to force a long screw into the socket. (The screw length should be less than 5.7 mm, JIS 5.5 mm).

- * Do not place the camera near equipment that has strong magnetism such as television or radio.
- * Remove the batteries before storing the camera, and keep it in a place free of dust and humidity
- * Do not attempt to disassemble or repair your camera yourself. If service is necessary, bring it to your dealer or send it to the authorized Ricoh distributors.

SPECIFICATIONS:

Type: 35 mm SLR with automatic electronic exposure control focal plane shutter.

Film Format and Frame Size: 35 mm film, 24X36mm

Lens Mount: K Mount

Standard Lens: 50 mm RIKENON f/2.0-P

Shutter: Electronically controlled, vertically moving focal plane shutter, Automatic: 16 sec. to 1/1000 sec. Manual: 16 sec. to 1/1000 sec. (by Quartz Control) B(Bulb)

Self-Timer: Operating delay of approx. 10 seconds. During operation, red LED blinks.

Viewfinder: Field of view covers 93% horizontally and vertically. Magnification: 0.88X(with 50 mm F1.4 standard lens). Display by LCD: Exposure adjustment, Bulb, Manual, Overexposure, Underexposure, Shutter speed indicator, Battery low warning signal, F-stop number, AE lock.

LED indicator: flash ready indicator.

Focusing: Diagonal split-image spot.

Exposure Meter: TTL full open metering for center-weighted average light reading.

Exposure Coupling Range: EV 0--EV 18 (with ISO 100 film, 50 mm F1.4 lens)

Film Speed Range: ISO 12 - 3200

Flash Terminal: X synchro contact

Accessory Shoe: Hot shoe(with Flash Ready Signal Contact)

Exposure Adjustment: Exposure adjustment system (+2 ~ - 2, in 1/3 steps), AE lock system

Film Advance: Single stroke film advance lever, 135 winding angle and 35 stand-off.

Automatic Film Advance: Possible with XR Winder-2 and PG-4 (Power Grip).

Exposure Counter: Additive, automatic resetting.

Film Rewind: Film rewind crank system.

Mirror: Swing back type quick return mirror.