

Ricoh XR-X3000

This camera manual library is for reference
and historical purposes, all rights reserved.

This page is copyright by mike@butkus.org, M. Butkus, NJ.

This page may not be sold or distributed
without the expressed permission of the producer
I have no connection with any camera company.

On-line camera manual library

If you find this manual useful, how about a donation of \$3 to:

M. Butkus, 29 Lake Ave., High Bridge, NJ 08829-1701
and send your e-mail address so I can thank you.
Most other places would charge you \$7.50 for a electronic copy
or \$18.00 for a hard to read Xerox copy.

This will help me to continue to host this site,
buy new manuals, and pay their shipping costs.
It'll make you feel better, won't it?

If you use Pay Pal, use the link below.
Use the above address for a check, M.O. or cash.



www.PayPal.me/butkus

Venmo @mike-butkus-camera

[Back to main camera manual page](#)

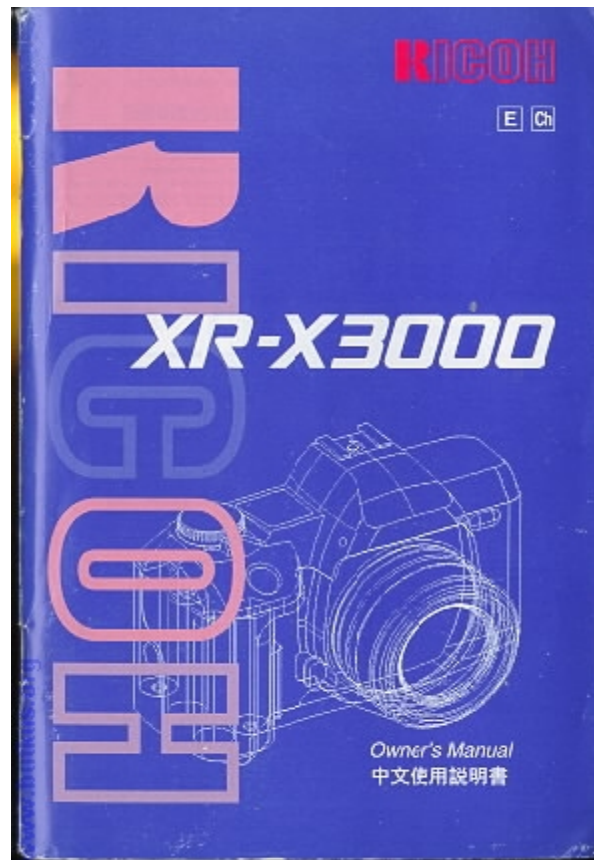

Posted on 6-20-02

I. LOCATING THE CONTROLS

When reading this manual, refer to "locating the controls" (fold out the front and back covers)

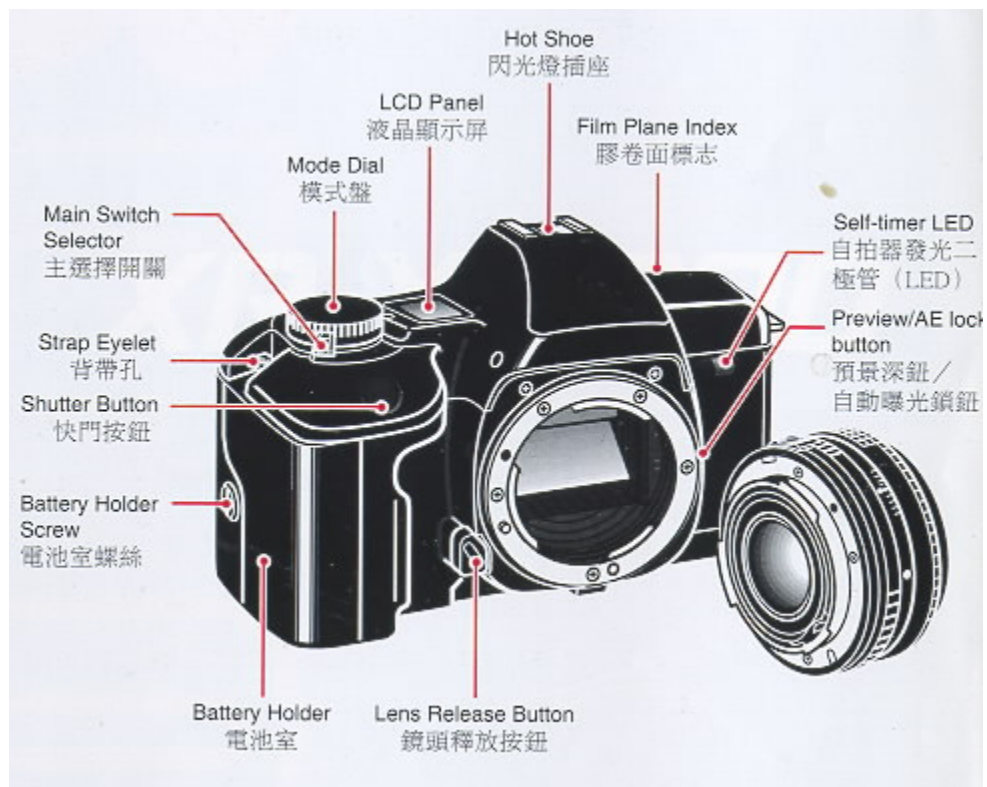

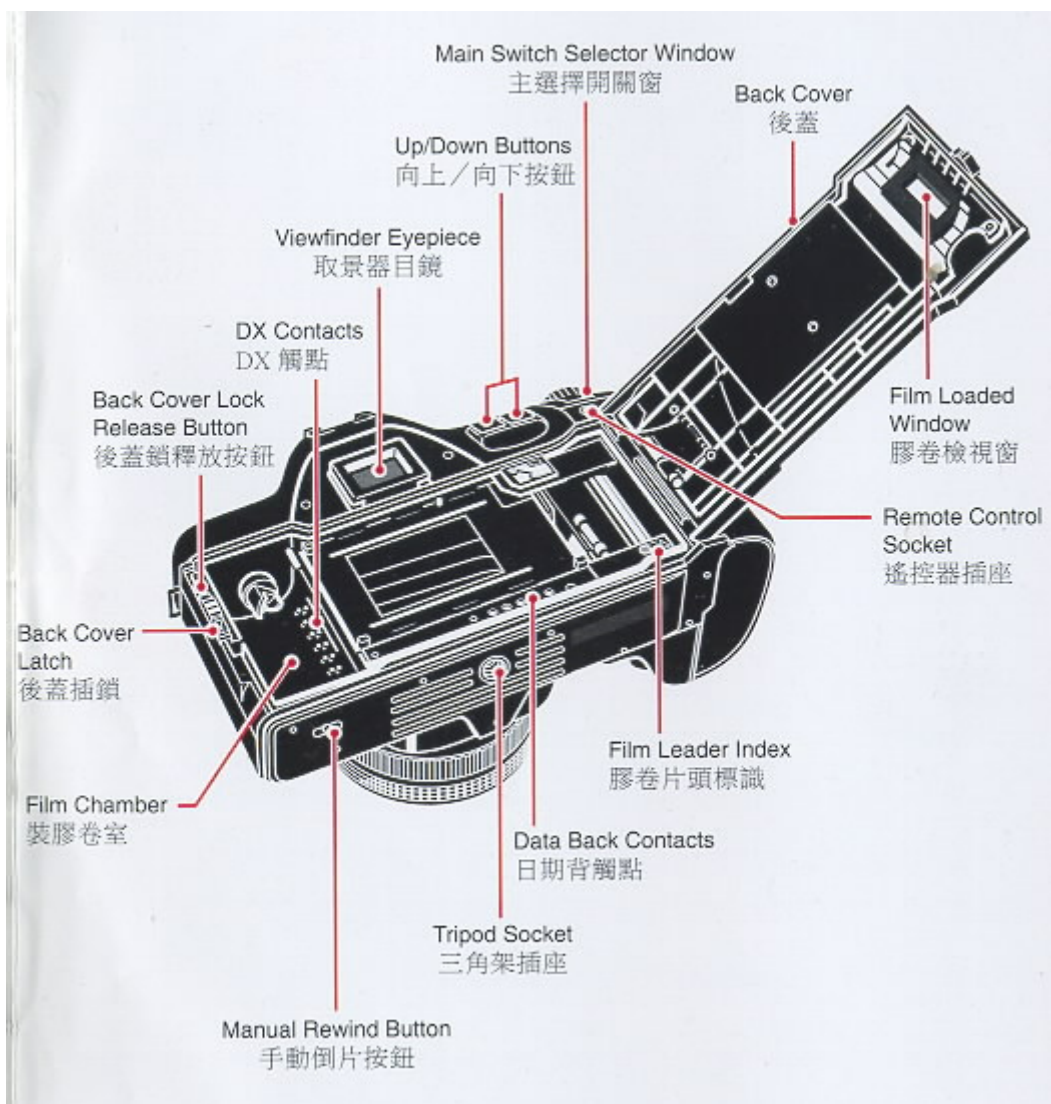

Shutter Button

When pressed halfway: The LCD panel and viewfinder display appear.
When pressed fully: The shutter is released.

Main Switch Selector

Sets the camera to L (Lock: power is turned off), A (Auto), or M (Manual) operation.

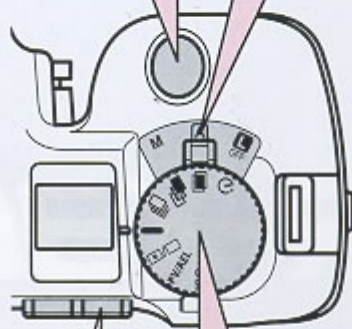
**Up/Down buttons**

Selects the following settings: Center-weighted average metering/Spot metering, Preview/AE Lock, ISO (DX setting override), Exposure compensation (in Auto operation), and Shutter speed (in Manual operation).

Mode Dial*

Selects the following modes: Self-timer, Multi Exposure, Auto Bracketing, Continuous Shooting, Normal, Exposure Metering User Setting (center-weighted average metering or spot metering), Preview/AE Lock User Setting, and ISO User Setting.

* Use the mode dial to select the desired mode, and press the up/down buttons to select the desired setting where applicable.

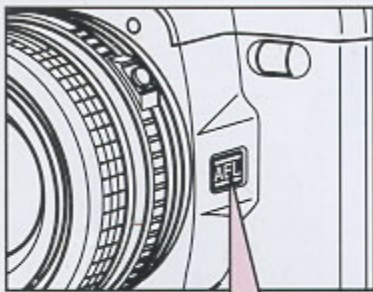
**Preview/AE lock button**

Locks the exposure value for precise exposure metering (AE Lock setting). Enables preview of the depth of field for the selected aperture (Preview setting).

L (Lock → P. 17)

Locks the operations and turns off the camera. Set to L (Lock) when the camera is not used.

A (Auto → P. 18)

Selects the optimum shutter speed automatically according to the user-selected aperture for creative control of the depth of field.

M (Manual → P. 19)

Enables manual user-selected aperture and shutter speed settings for individual creative effects or difficult lighting conditions.

**Self-timer Mode (→ P. 26)**

Enables self-timer shooting. The 10-second timer is activated when the shutter button is pressed.

**Multi Exposure Mode (→ P. 27)**

Enables multi exposure shooting. The film does not advance when the shutter button is pressed to allow taking several exposures on the same frame.

**Auto Bracketing Mode (→ P. 28)**

Enables auto bracketing exposure compensation. Three frames will be shot; an underexposed (-0.5 EV), a correctly exposed (0 EV), and an overexposed (+0.5 EV) frame.

**Continuous Shooting Mode (→ P. 28)**

Enables continuous shooting as long as the shutter button is pressed.

**Normal Mode (→ P. 29)**

Under normal conditions, set the camera to the Normal mode.

**Exposure Metering User Setting Mode (→ P. 29)**

Allows setting for center-weighted average metering or spot metering .

**Preview/AE Lock User Setting Mode (→ P. 30)**

Allows setting for the Preview mode or the AE Lock mode. The Preview mode enables the preview of the depth of field for the selected aperture. The AE Lock mode locks the exposure value for precise exposure metering.

**ISO User Setting Mode (→ P. 32)**

Allows setting for ISO manual override of the film for advanced applications. Under normal conditions, the camera automatically sets the ISO film speed for DX-coded films ranging from ISO 25 to 5000 (ISO 12 to 6400 for manual override setting).

Up/Down Buttons Operations

Main Switch Selector	L*	A**	M***
Mode Dial			
<ul style="list-style-type: none"> • Self-timer Mode • Multi Exposure Mode • Auto Bracketing Mode • Continuous Shooting Mode • Normal Mode 	Locked	Exposure Compensation	Manual Shutter Speed
• Exposure Metering User Setting Mode		<input type="checkbox"/> or <input checked="" type="checkbox"/>	
• Preview/AE Lock User Setting Mode		Preview or AE Lock	
• ISO User Setting Mode		ISO 12 to 6400	

*L: Locked. The power is turned off.

**A: Auto operation

***M: Manual operation

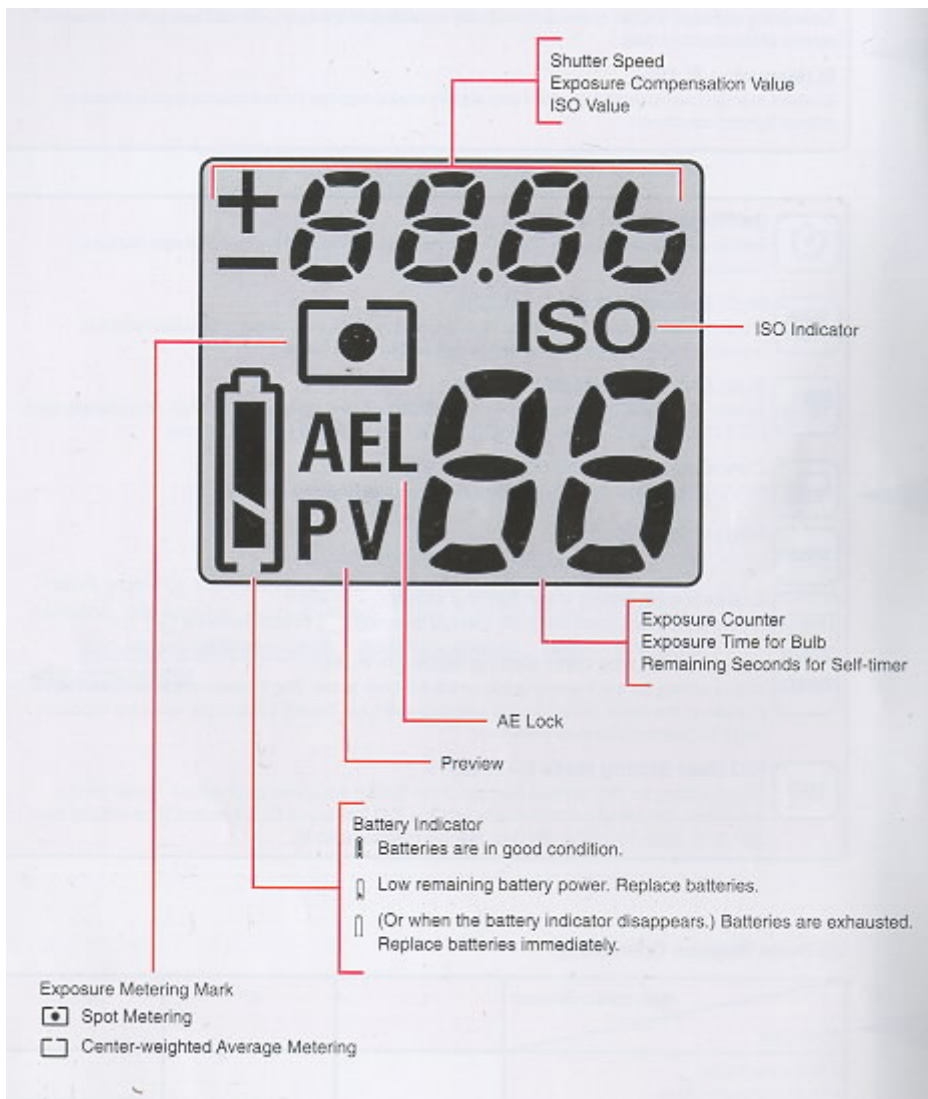

Reading the Exposure Indicator The exposure indicator is displayed in the viewfinder display and the exposure compensation value is displayed on the LCD panel in the following conditions:

- In Manual operation
- When the exposure compensation has been set.
- When the exposure compensation is being set.

In Manual operation or for exposure compensation, the exposure indicator in the viewfinder display indicates the difference between the correct exposure value (EV) and the current exposure compensation setting.

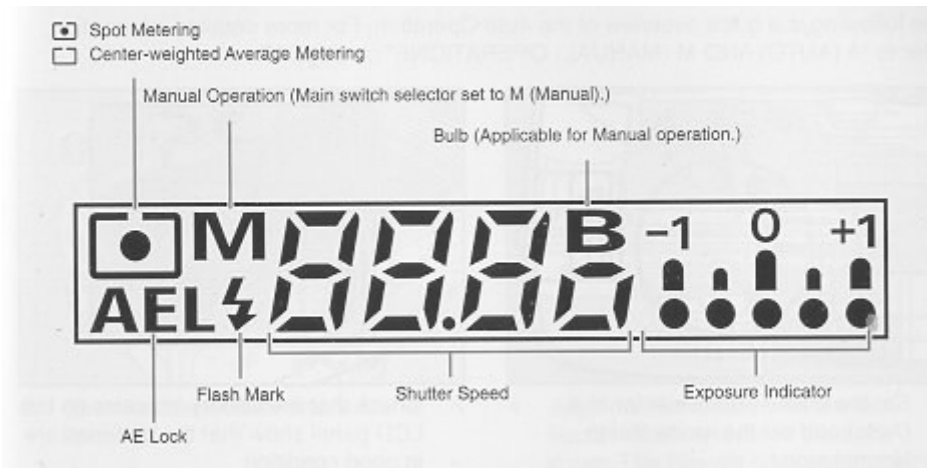

The * mark flashes when the value exceeds -1 EV or +1 EV.

Exposure compensation can be set within the range of +/- 4 EV in 0.5 EV increments. The shutter speed in the viewfinder display flashes when the current exposure setting is beyond the exposure metering range. However, the overexposure or underexposure can still be taken deliberately to capture a particular creative effect. Nevertheless, to avoid incorrect exposure, select a larger or smaller aperture, select a faster or slower shutter speed, or use a flash unit as necessary.

IV. QUICK GUIDE IN AUTO OPERATION

The following is a quick overview of the Auto Operation. For more detailed information, refer to "A (AUTO) AND M (MANUAL) OPERATIONS" on page 17.

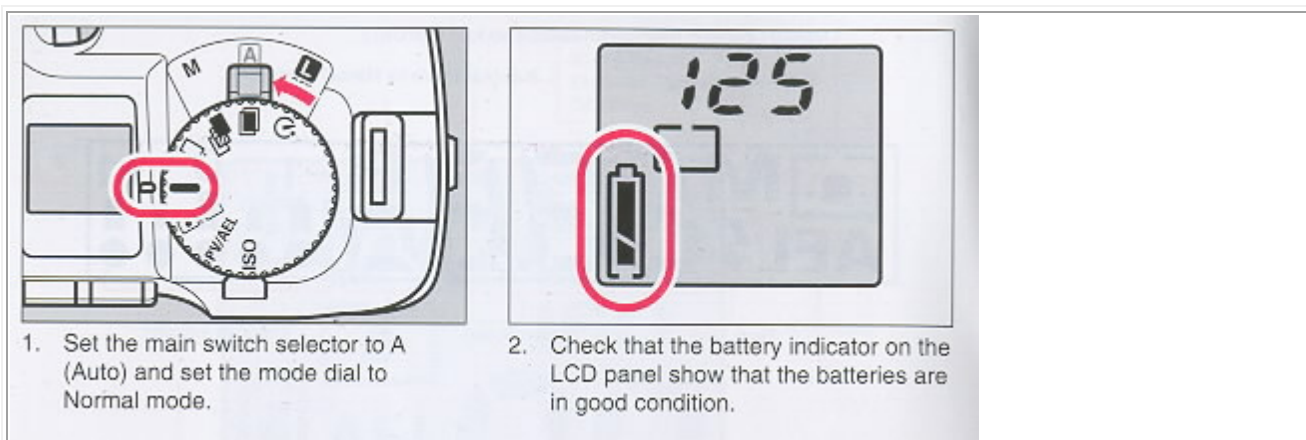

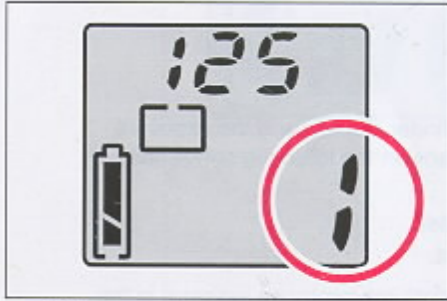

5. Make sure that the exposure counter displays "1".

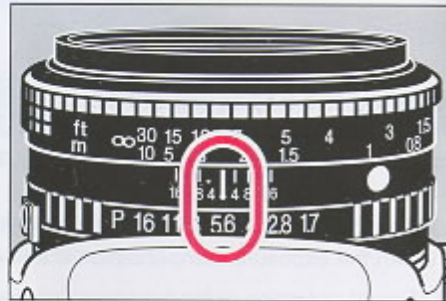

6. Set to the desired lens aperture.*

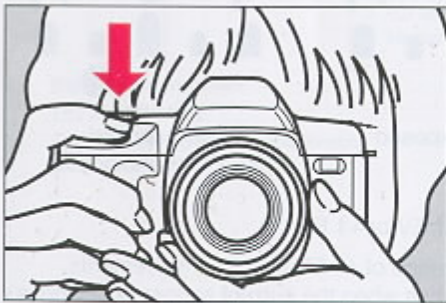

9. Press the shutter button to shoot.

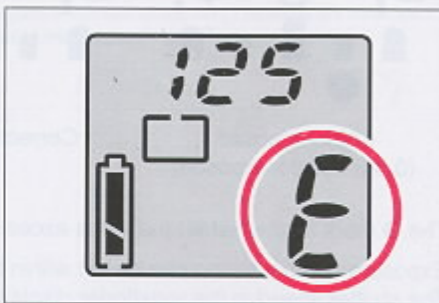

10. When the film reaches the end, the film rewinds to completion automatically and the exposure counter displays "E".

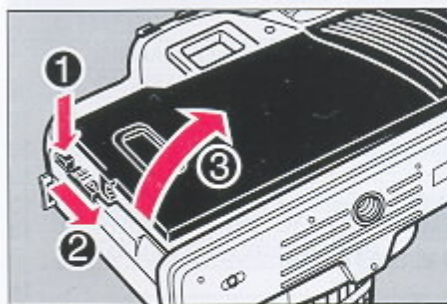

3. Open the back cover and load the film.

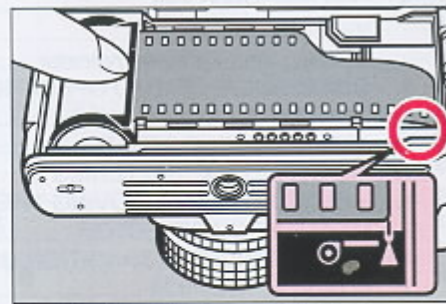

4. Align the film leader with the film leader index, and close the back cover. The film will advance to the first frame automatically.

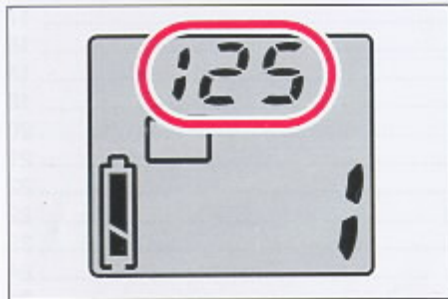

7. Check the shutter speed on the LCD panel.

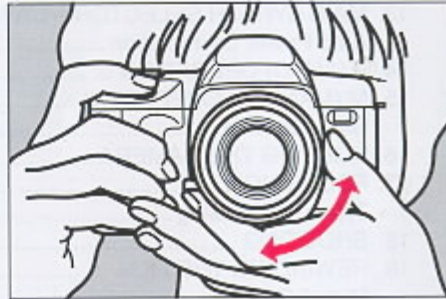

8. Hold the camera and focus on the subject.

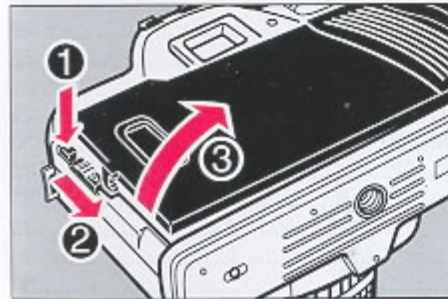

11. Open the back cover and remove the film.

* In Auto operation, the desired lens aperture is selected by the user while the camera automatically and continuously controls the corresponding shutter speed between 1/2000 and 32 seconds.

V. CONTENTS

1. LOCATING THE CONTROLS 3

2. FUNCTION MAP 4

3. LCD INFORMATION 6

Viewfinder Display 7

Reading the Exposure Indicator 7

4. QUICK GUIDE IN AUTO OPERATION 8

5. CONTENTS 10

6. ATTACHING THE STRAP 12

7. INSERTING THE BATTERIES 12

8. MOUNTING AND REMOVING THE LENS 13

9. MAIN SWITCH SELECTOR ; 14

10. MONITORING THE CONDITION OF THE BATTERIES 14

11. LOADING THE FILM	15
12. SETTING THE FILM SPEED AUTOMATICALLY	16
DX Films	16
Non-DX Films	16
A (AUTO) AND M (MANUAL) OPERATIONS	
13. MAIN SWITCH SELECTOR--UA/M	17
Auto Power Off Function	18
14. A (AUTO) OPERATION	18
15. M (MANUAL) OPERATION	19
Bulb Function	20
16. HOLDING THE CAMERA	21
17. FOCUSING	22
Types of Focusing	22
18. SHOOTING	23
19. REWINDING THE FILM	24
Midroll Rewind	24
MODES	
20. SETTING THE MODES	25
21. SELF-TIMER MODE	26
22. MULTI EXPOSURE MODE	27
23. AUTO BRACKETING MODE	28
24. CONTINUOUS SHOOTING MODE	28
25. NORMAL MODE	29
26. EXPOSURE METERING USER SETTING MODE	29
27. PREVIEW/AK LOCK USER SETTING MODE	30
28. ISO USER SETTING MODE	32

29. EXPOSURE COMPENSATION 33

Shooting in Backlit Conditions 33

Dominantly White Subjects 34

Dominantly Dark-colored Subjects 34

FLASH PHOTOGRAPHY

30. FLASH PHOTOGRAPHY WITH SL-303P, SL-403P 36

31. FLASH PHOTOGRAPHY WITH FLASH UNITS OTHER THAN RICOH 37

OTHERS

32. INFRARED FILM 38

33. DIOPTRIC LENSES 38

34. INTERCHANGEABLE VIEWFINDER SCREENS 39

35. RELEASE SWITCH 39

36. CARE OF BATTERIES 40

37. DATA BACK 7 40

38. PROPER CARE OF YOUR CAMERA 44

39. MAJOR SPECIFICATIONS 45

VI. ATTACHING THE STRAP

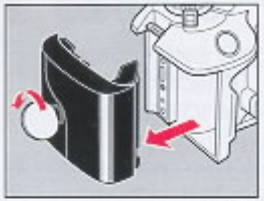

Fig. 1

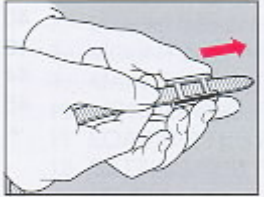

Fig. 2

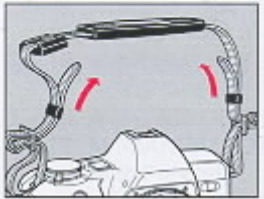

Fig. 3

1. Remove the battery holder by turning the battery holder screw counterclockwise with a coin. (Fig. 1)
2. Slip the viewfinder cap and shoulder pad onto the strap. (Fig. 2)
3. Run the strap through the strap eyelet as shown. (Fig. 3)

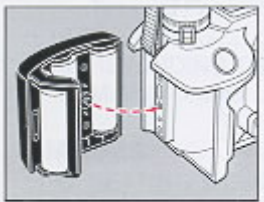

Fig. 4



Fig. 5

4. Secure the battery holder to the camera body by turning the battery holder screw clockwise with a coin. (Fig. 4)
5. Adjust the strap length as desired.

VII. INSERTING THE BATTERIES

1. Remove the battery holder.
2. Insert four new M-size alkaline batteries and make sure that the + and - on the batteries are aligned according to the polarity diagram inside the battery holder. (Fig. 5)

<<< update - I have been told a Olympus eyecup and other accessories will work on XR cameras >>>

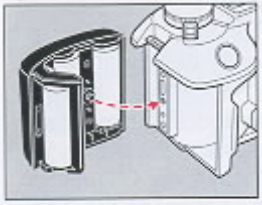

Fig. 6

3. Secure the battery holder to the camera body by turning the battery holder screw clockwise with a coin. (Fig. 6)

Notes on Batteries

- The condition of the batteries should be monitored frequently. For more information, refer to "MONITORING THE CONDITION OF THE BATTERIES" on page 14.
- Be sure to replace all four batteries at once. Replace with the same brand of batteries.
- Do not use AA-size lithium batteries.

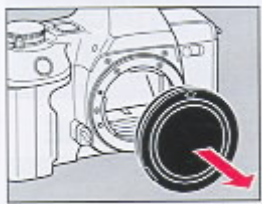

Fig. 7

VIII. MOUNTING AND REMOVING THE LENS

1. Remove the camera body cap. (Fig. 7)

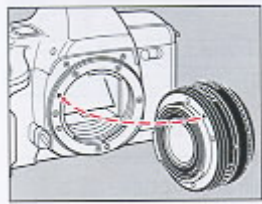

Fig. 8

2. Align the red dot on the camera with the red dot on the lens and mount the lens on the camera. (Fig. 8)

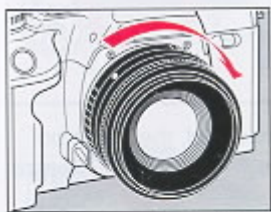

Fig. 9

3. Turn the lens in the direction shown by the arrow until it clicks into place. (Fig. 9)

- If the lens is to be removed from the camera for a certain period of time, use the camera body cap to avoid dust and foreign particles from entering your camera. Likewise, use the front and rear lens caps to protect your lens also.

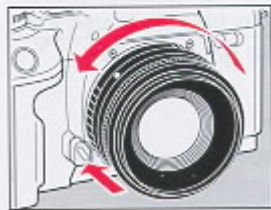

Fig. 10

4. To remove the lens, press the lens release button, then turn the lens in the direction shown by the arrow. (Fig. 10)

- For best results, use Ricoh lenses only. Optimum performance of the camera may be compromised by using other lenses.

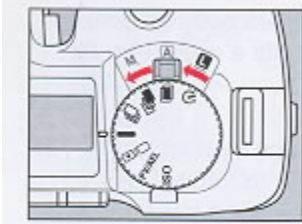

Fig. 11

VVI. MAIN SWITCH SELECTOR

1. Set the main switch selector to A (Auto) or M (Manual). (Fig. 11)

· If the camera is left unattended for about 30 seconds, the power switches off automatically and the display on the LCD panel disappears. The Auto Power Off function prevents unnecessary waste of the battery power. The current information contained in the camera memory is retained.

Lightly press the shutter button to turn on the power and update the LCD panel. For maximum battery life, always set the main switch selector to L (Lock) when the camera is not used.



Fig. 12

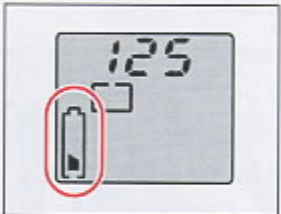

Fig. 13

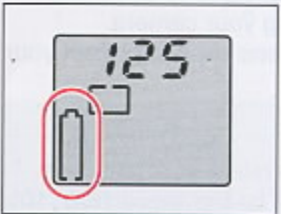

Fig. 14

X. MONITORING THE CONDITION OF THE BATTERIES

When the main switch selector is set to A (Auto) or M (Manual), the battery condition is displayed on the LCD panel.

1. Batteries are in good condition when the I symbol appears on the LCD panel. (Fig. 12)

2. When the batteries are nearly exhausted, the a symbol is displayed on the LCD panel. (Fig. 13) Replace with four new M-size alkaline batteries.

3. When the batteries are virtually exhausted, the n symbol appears on the LCD panel. Replace with four new AA-size alkaline batteries. (Fig. 14)

· In extremely cold temperatures, the n symbol may appear on the LCD panel. (In cold temperatures, the battery voltage is reduced.) You may be able to use the camera if you remove and warm up the batteries.

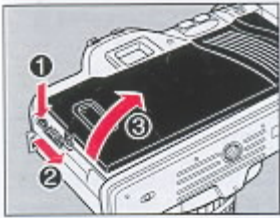

Fig. 15

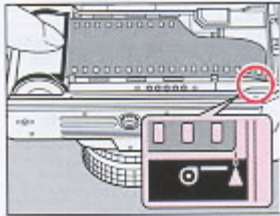

Fig. 16

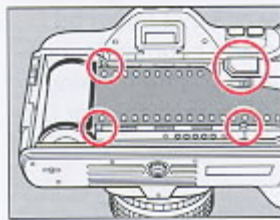

Fig. 17

XI. LOADING THE FILM

Always avoid direct sunlight when loading the film.

1. Press the back cover lock release button and slide the back cover latch down to open the back cover. (Fig. 15)

2. Load the film cassette into the film chamber and pull out the film leader so that it extends past the film leader index. (Fig. 16)

· If the film leader is pulled out more than necessary when loading, the total number of exposures may be reduced.

3. Make sure that the film stays within the film guides, and that the upper sprocket edge is under the guide plate. (Fig. 17)

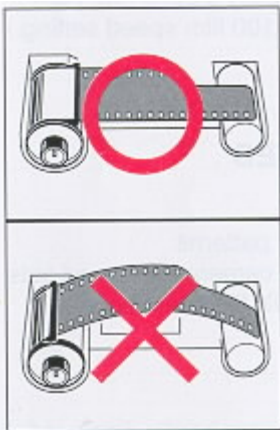

Fig. 18

The film may not load properly if the film leader does not lie flat. Make sure that the film lies flat as shown. (Fig. 18)

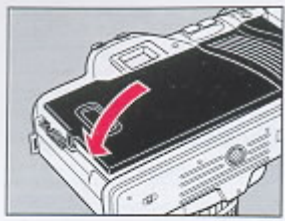

Fig. 19

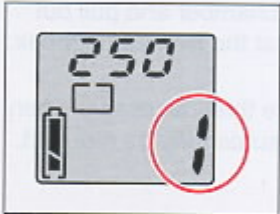

Fig. 20

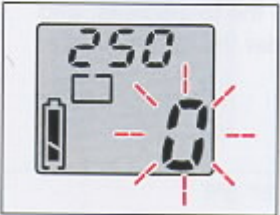

Fig. 21

4. Close the back cover so that the back cover latch snaps shut and returns to the original position. (Fig. 19) If the film has been properly loaded, the film speed appears on the LCD panel for about 2 seconds. Then, the exposure counter displays "1". (Fig. 20)

- If the display on the LCD panel disappears, lightly press the shutter button to turn on the power and update the LCD panel.

- The ISO setting on the LCD panel can be checked by looking through the film loaded window on the back cover of the camera (applicable when the Data Back is not attached). The current ISO setting can be determined also by turning the mode dial to select the ISO User Setting mode.

5. If the film has not advanced properly or is not taken up onto the film take-up spool, the exposure counter flashes "0". The shutter will lock also to prevent you from taking a picture until the film is loaded properly. (Applicable for DX coded films only.) Reload the film by repeating steps 1-4 as described above. (Fig. 21)

- If non-Ding films are loaded in this camera, no LCD warnings will appear and the shutter can be released. (The film speed must be set manually also. If not, non DX films will be set to the default 100 film speed setting.)

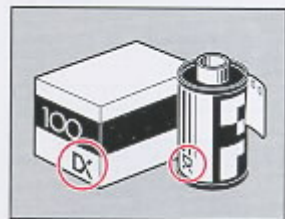

Fig. 22

XII. SETTING THE FILM SPEED AUTOMATICALLY

DX-coded films have black-and-silver patterns corresponding to film speeds that the camera reads and sets automatically. Your camera accepts DX films with speeds ranging from ISO 25-5000. (Fig. 22)

DX Films

The film speed and the "ISO" indicator are briefly displayed on the LCD panel.

For advanced applications, you may wish to raise or lower the ISO speed of a DX-coded film. You can override the automatic ISO setting manually between ISO 12 to 6400.

Refer to "ISO USER SETTING MODE" on page 32.

Non-DX Films

Non-DX films must be set manually. If not, the film will be set to the default 100 film speed setting. For more information on loading non-Ding films, refer to page 32.

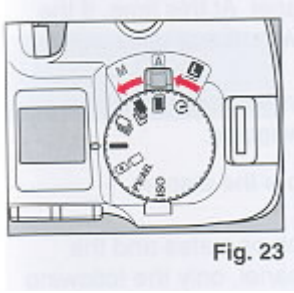

Fig. 23

A (AUTO) AND M (MANUAL) OPERATIONS

XIII. MAIN SWITCH SELECTOR--L/A/M

1. Set the main switch selector to the desired operation.
(Fig. 23)

L (Lock)

Locks the operations and turns off the camera. Set to L

(Lock) when the camera is not used.

A (Auto ~ P. 18)

Selects optimum shutter speed automatically according to the user-selected aperture for creative control of the depth of field.

M (Manual ~ P. 19)

Enables manual user-selected aperture and shutter speed settings for individual creative effects or difficult lighting conditions.

- The LCD panel and the viewfinder display operate when A (Auto) or M (Manual) is selected.
- If there is a film loaded in the camera, the film speed will be displayed for the first 2 seconds.

2. Check the batteries.

- Refer to "MONITORING THE CONDITION OF THE BATTERIES" on page 14.
- If the main switch selector is set to L (Lock), the power will be completely cut off. The LCD panel and the viewfinder display will not operate.
- The following modes will be canceled when the main switch selector is set to L (Lock).
 - AE Lock setting (in the Preview/AE Lock User Setting mode)
 - Self-timer mode
- To prevent unnecessary battery depletion, set the main switch selector to L (Lock) when you are not using the camera.

Auto Power Off Function

If the camera controls are not operated or camera operations** are not performed for about 30 seconds, the display will disappear on the LCD panel. At this time, if the shutter button is pressed lightly halfway, the display will appear again. ~ All buttons, mode dial, and main switch selector. ** Shooting, film loading, and film rewinding.

- The mode settings selected before the display disappears, will not be canceled.
- When the Auto Power Off function operates and the display disappears on the LCD panel, only the following can be operated so that the display will appear again: shutter button, manual rewind button and the main switch selector. To set or change the mode settings, press the shutter button halfway to operate the LCD panel.
- If the camera is not operated for about 10 seconds, the display inside the viewfinder will disappear. By pressing the shutter button halfway, the display will appear.

XIX. A (AUTO) OPERATION

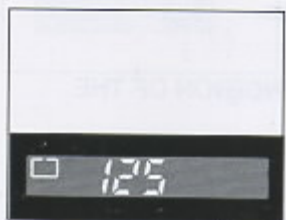

Fig. 24

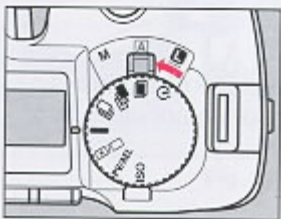

Fig. 25



Fig. 26

18

The camera is set to A (Auto) operation when the following viewfinder display appears. Note that the viewfinder display may vary slightly according to the current shutter speed and settings (i.e., AE lock, exposure metering, flash, bulb, and exposure compensation settings). (Fig. 24)

· If the LCD panel or viewfinder display is not operating, press the shutter button halfway and the display will appear.

1. Set the main switch selector to A (Auto). (Fig. 25)

Make sure that the mode dial is set to either Self-timer

Multi Exposure, Auto Bracketing, Continuous Shooting, or Normal mode.

2. Set to the desired lens aperture. (Fig. 26)

· If the aperture is set to "P" or "A", turn the aperture ring while pressing the ~ P" or "A" lock pin.

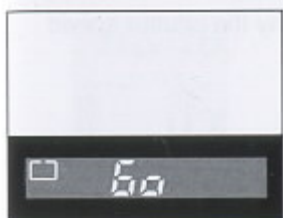

Fig. 27



Fig. 28



Fig. 29

3. Check the LCD panel and look through the viewfinder and make sure that the viewfinder display is operating. (Fig. 27)

- The shutter speed appears in the viewfinder display.
- The shutter speed flashes in the viewfinder display when the subject is underexposed or overexposed. Under certain conditions, a subject may be underexposed even when the slowest shutter speed (i.e., 32 seconds) is set. "L32" flashes in the viewfinder display. Use a flash unit, the Bulb function, or simply select a larger aperture (smaller number aperture setting) as necessary. Likewise, a subject may be overexposed even when the fastest shutter speed (i.e., 1/2000 th second) is set. "2000" flashes in the viewfinder display. Use a neutral density filter or simply select a smaller aperture (larger number aperture setting) as necessary. (Fig. 28, 29)

XV. M (MANUAL) OPERATION

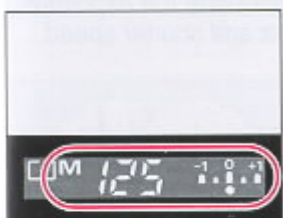

Fig. 30

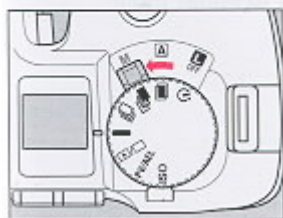

Fig. 31

The camera is set to M (Manual) operation when the following viewfinder display appears. Note that the viewfinder display may vary slightly according to the current shutter speed and settings (i.e., AE lock, exposure metering, flash, bulb, and exposure compensation settings). (Fig. 30) Make sure that "M" is displayed in the viewfinder display and that the lens aperture is not set to "P" or "A".

1. Set the main switch selector to M (Manual). (Fig. 31)

Make sure that the mode dial is set to either Self-timer,

Multi Exposure, Auto Bracketing, Continuous Shooting, or Normal mode.

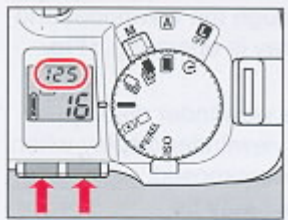

Fig. 32

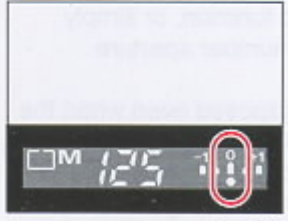

Fig. 33

2. Press the up/down buttons to display the shutter speed you wish to set. (Fig. 32)

3. Look through the viewfinder and adjust the aperture setting by turning the aperture ring. To change the shutter speed, press the up/down buttons. The exposure indicator appears in the viewfinder display. Look at the exposure indicator when setting the aperture and shutter speed. When the dot (a) of the exposure indicator is under the "0", the correct exposure is set. (Fig. 33) The subject is underexposed when the dot (O) of the exposure indicator is towards -1. Likewise, the subject is overexposed when the dot (O) of the exposure indicator is towards +1. For underexposed pictures, set a larger aperture (smaller number aperture setting) or slower shutter speed. For overexposed pictures, set a smaller aperture (large number aperture setting) or faster shutter speed.

· If the viewfinder display is not operating, press the shutter button halfway and the display will appear.

· Naturally, exposure compensation cannot be set in Manual operation because the desired compensation can be deliberately selected by looking at the exposure indicator when setting the aperture and shutter speed.

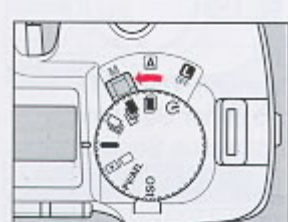

Fig. 34

Bulb Function

If the shutter speed is set to "bulb" in Manual operation, the shutter will remain open for as long as you keep the shutter button pressed. This is referred to as bulb photography. Bulb photography is used for shooting night scenes, or other images with long exposure times.

1. Set the main switch selector to M (Manual) (Fig. 34) Make sure that the mode dial is set to either Multi Exposure, or Normal mode.



Fig. 35

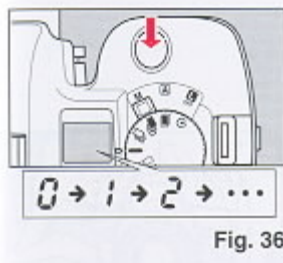

Fig. 36

2. Press the up/down buttons to display "bulb" on the LCD

Panel. (Fig. 35)

- The Self-timer and Auto Bracketing modes are not applicable when the shutter speed is set to "bulb".

- The "B" mark is also displayed in the viewfinder display.

3. Set to the desired lens aperture.

- If the aperture is set to "P" or "A", turn the aperture ring while pressing the "P" or "A" lock pin.

4. Keep the shutter button pressed for as long as you wish the shutter to remain open. (Fig. 36)

- If you remove your finger from the shutter button, the shutter will close

- The exposure counter on the LCD panel will display the time (in seconds) that the shutter has been open.

- To avoid camera shake, use a tripod and a release switch.

- If the battery runs out of power, the shutter may prematurely close.



Fig. 37



Fig. 38



XVI. HOLDING THE CAMERA

To prevent camera shake, be sure to hold the camera properly when shooting. Support the camera on the palm of your left hand so that you can turn the focusing ring with your fingers. (Fig. 37)

With your right hand lightly grasp the grip and place your index finger lightly over the shutter button. When pressing the shutter button, grasp the grip firmly. Place your elbows against your body when shooting with the camera in a horizontal position, or place your left elbow against your body when shooting with the camera in a vertical position. (Fig. 38)

Place your forehead against the camera and look through the viewfinder.

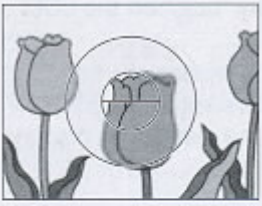
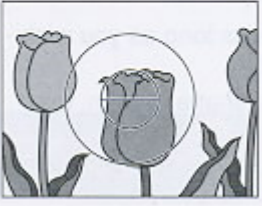
XVII. FOCUSING

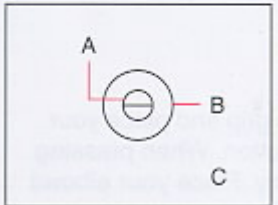
 <p>Fig. 39</p>  <p>Fig. 40</p>	<p>Focusing is achieved with the Split-image, Microprism or Matte focusing screen in the viewfinder. The viewfinder image is crucial for accurate focusing of the lens, and therefore greatly influences image sharpness. Different photographic applications often require different focusing screens. The optimum type of focusing depends on the subject and the lens being used. (Fig. 39, 40)</p>
 <p>Fig. 41</p>  <p>Fig. 42</p>	<p>While looking through the viewfinder, focus by turning the focusing ring. (Fig. 41)</p> <p>Types of Focusing</p> <p>A. Split-image The area inside the central circle is the split image. When both images in the split-image area form a single clear image, the subject is in focus. The split-image helps you focus quickly and easily on subjects with clear lines or contours. (Fig. 42)</p> <p>B. Microprism The area inside the outer circle is the microprism. When the image stops "flickering" and is sharp and clearly visible, the subject is in focus. The microprism allows fast and precise focusing on subjects without recognizable lines or contours. (Fig. 42)</p>

C. Matte screen

The area outside the microprism is the matte screen. Focusing is done by sight and requires practice as the transition from unsharp to sharp is gradual rather than abrupt. The matte screen helps you focus precisely with lenses of longer focal lengths as well as in the macro range. (Fig. 42)

· When you use a small aperture (large number aperture setting) with a lens such as a zoom lens, half of the split image becomes dark. In this case, use the matte screen to focus.

XVIII. SHOOTING

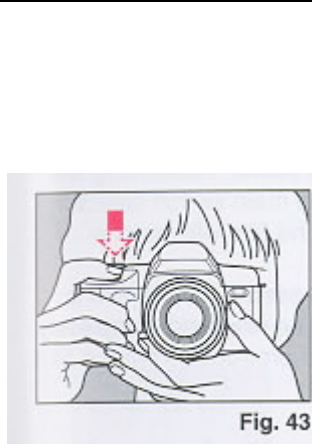

1. Press the shutter button halfway. (Fig. 43)

- The LCD panel and viewfinder display operate.
- The shutter button can be pressed in two ways. If it is pressed halfway, the LCD panel and the viewfinder display operate. If it is pressed fully, the shutter is released.
- If the camera is not operated for about 10 seconds, the display inside the viewfinder will disappear. By pressing the shutter button halfway, the display will appear.
- If the camera is not operated for about 30 seconds, the display on the LCD panel will disappear. By pressing the shutter button halfway, the display will appear.

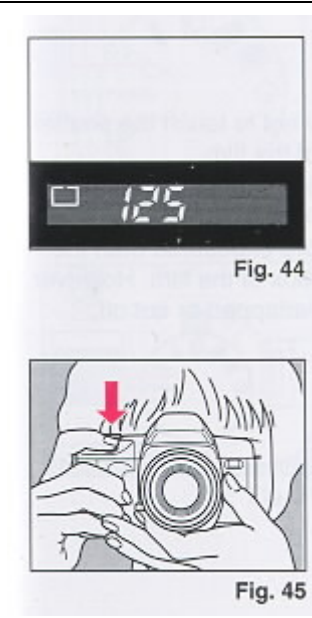

2. Confirm that the viewfinder display is operating. (Fig. 44)

Fig. 44 indicates the viewfinder display in Auto operation.

The number denotes the current shutter speed. Note that the viewfinder display may vary slightly according to the current operation (i.e., Auto or Manual) and settings (i.e., AE lock, exposure metering, flash, bulb, and exposure compensation settings).

- When a slow shutter speed has been set, use a tripod to prevent camera shake.

3. Press the shutter button. (Fig. 45)

- The film advances when the shutter is released.

XIX. REWINDING THE FILM

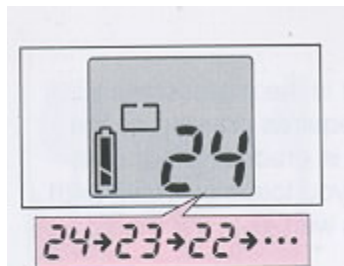

Fig. 46

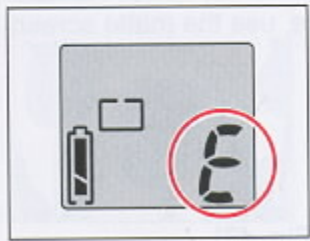

Fig. 47

1. When the film has reached the end, the film rewinds to completion automatically while the exposure counter counts down. (Fig. 46)

· When the film is completely rewound, the exposure counter displays "E". (Fig. 47)

2. While pressing the back cover lock release button, slide the back cover latch down and open the back cover.

3. Remove the film.

· When you are in a quiet location and the noise produced during film rewinding is disturbing, set the main switch selector to L (Lock) to turn off the power. Rewinding will be temporarily stopped. When the main switch selector is set to A (Auto) or M (Manual), the film will resume rewinding.

· If the manual rewind button is pressed while the film is rewinding, the film leader will not be rewound completely so that a portion of the film leader protrudes from the film cassette.

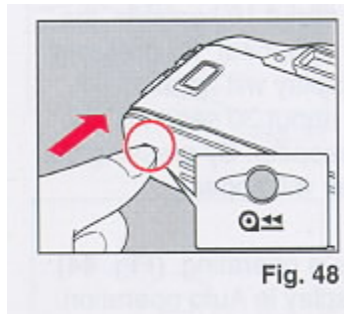

Fig. 48

Midroll Rewind

Press the manual rewind button. (Fig. 48)

· When removing the film, be careful not to touch the shutter with your fingers or with the edge of the film.

· The shutter cannot be released when "E" is displayed on the LCD panel.

· It is sometimes possible to take more exposures than the specified number indicated on the box of the film. However, these "extra" exposures may be overlapped or cut off.

MODES

XX. SETTING THE MODES



Fig. 49

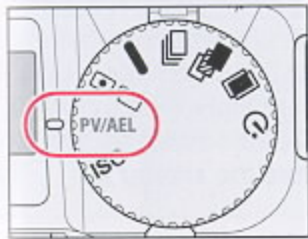

Fig. 50

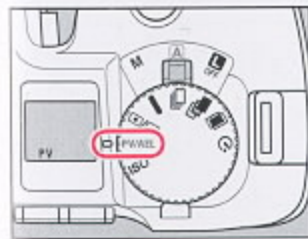

Fig. 51

Use the mode dial to select the desired mode (i.e., Self timer, Multi Exposure, Auto Bracketing, Continuous Shooting, Normal, Exposure Metering User Setting, Preview/ AE Lock User Setting, and ISO User Setting modes). Press the up/down buttons to select the desired setting (i.e., Exposure Metering User Setting, Preview/AE Lock User Setting, and ISO User Setting) and to set the shutter speed in Manual operation or exposure compensation in Auto operation. A For a brief explanation, refer to the "FUNCTION MAP" on pages 4-5.

For more information on modes and settings, refer to the appropriate sections for each mode.

The settings are displayed on the LCD panel. (Fig. 49)

· If the LCD panel or viewfinder display is not operating, press the shutter button halfway and the display will appear. The modes cannot be set when the display is not operating

1. Turn the mode dial to select the mode you wish to set. (Fig. 50)

2. Press the up/down buttons and set or adjust the value of the mode you have selected. (Fig. 51) For more information, refer to "Up/Down Buttons Operations" on page 5.

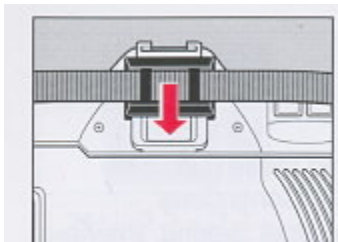

Fig. 52

XXI. SELF-TIMER MODE

1. After focusing, slip the viewfinder cap attached to the strap over the viewfinder eyepiece as necessary. (Fig. 52)

· The viewfinder cap is used to avoid incorrect exposure due to stray light which may enter the viewfinder eyepiece. This is to ensure that the metering system is not adversely affected.

· The Self-timer mode is not only useful for self-portraits but also for shake-free exposures with slow shutter speeds.

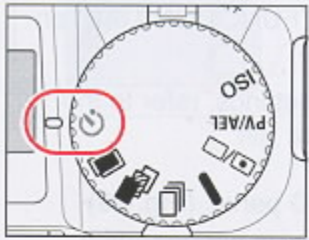

Fig. 53

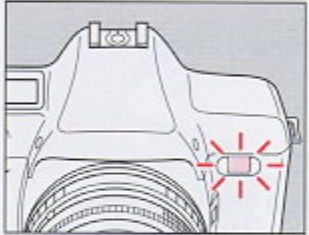

Fig. 54

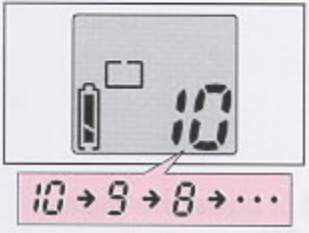

Fig. 55

2. Turn the mode dial to select A) (Self-timer mode). (Fig. 53)

3. Press the shutter button.

- When the self-timer has been activated, the self-timer LED will start flashing and about 10 seconds later, the shutter will be released. The self-timer LED remains lit for the last 2 seconds before the shutter is released. (Fig. 54)

- To cancel the Self-timer mode after pressing the shutter button, turn the mode dial to select another mode, or set the main switch selector to L (Lock) to turn off the power.

- The exposure counter on the LCD panel indicates the number of seconds remaining before the shutter is released. (Fig. 55)

- The Self-timer mode is not applicable when the shutter speed is set to "bulb".

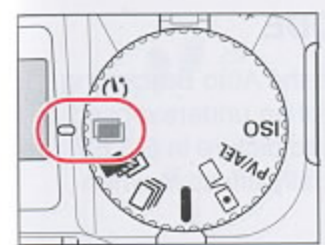

Fig. 56

XXII. MULTI EXPOSURE MODE

1. Turn the mode dial to select (Multi Exposure mode). (Fig. 56)



2. Press the shutter button as many times as necessary to take several exposures on the same frame.

- The film will not advance and the exposure counter number will remain the same.

- To cancel the Multi Exposure mode, turn the mode dial to select another mode, or set the main switch selector to L (Lock) to turn off the power.

- When developing negative films, make sure that you indicate that the film contains multi exposure shots where applicable. The multi exposed shot may be mistaken for an error and may not be printed.

XXIII. AUTO BRACKETING MODE

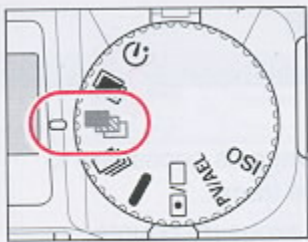

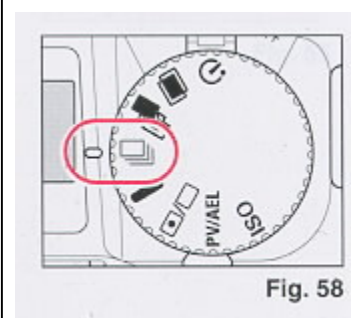



Fig. 57

When the shutter button is pressed in the Auto Bracketing mode, the camera will take 3 frames of an underexposed, a correctly exposed, and an overexposed picture in 0.5 EV increments. Auto Bracketing is especially effective when using a reversal (slide) film.

 <p>-0.5 EV</p> <p>0 EV</p> <p>+0.5 EV</p>	<ol style="list-style-type: none"> 1. Turn the mode dial to select (Auto Bracketing mode). (Fig. 57) 2. Press the shutter button. <ul style="list-style-type: none"> · The camera will take 3 frames in the following order: underexposed (-0.5 EV), correctly exposed (0 EV), and overexposed (+0.5 EV). · To cancel the Auto Bracketing mode, turn the mode dial to select another mode. · When the Auto Bracketing mode is combined with exposure compensation or AE lock, the exposure range will be based on the selected exposure compensation value or the locked exposure value respectively. For example, when exposure compensation or the locked exposure value is -1.0 EV: the exposure range will be -1.5 EV, -1.0 EV, and -0.5 EV. · The Auto Bracketing mode is applicable for Manual operation also. · The Auto Bracketing mode cannot be combined with flash photography (i.e., Ricoh flash units such as the Speedlite 303P, 323, 403P, etc.). · The Auto Bracketing mode is not applicable when the shutter speed is set to "bulb".
---	---

XXIV. CONTINUOUS SHOOTING MODE

 <p>Fig. 58</p>	<p>Continuous shooting occurs for as long as you press the shutter button in the Continuous Shooting mode.</p> <ol style="list-style-type: none"> 1. Turn the mode dial to select  (Continuous Shooting mode). (Fig. 58) 2. Press the shutter button. Continuous shooting is enabled as long as the shutter button is pressed. <ul style="list-style-type: none"> · To cancel the Continuous Shooting mode, turn the mode dial to select another mode, or set the main switch selector to L (Lock) to turn off the power.
---	---

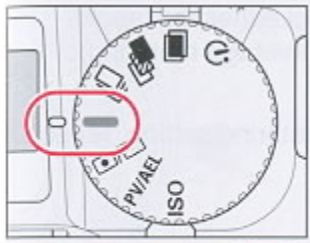

Fig. 59

XXV. NORMAL MODE

When done with using other modes, set the camera to the Normal mode. Under normal conditions, the camera should be set to the Normal mode.

1. Turn the mode dial to select -- (Normal mode). (Fig. 59)
When you do not wish to operate the Self-timer, Multi Exposure, Auto Bracketing, or Continuous Shooting mode, and do not require to change the Exposure Metering User Setting, Preview/AE Lock User Setting, or ISO User Setting mode, set the camera to the Normal mode.

2. Press the shutter button.



Fig. 60

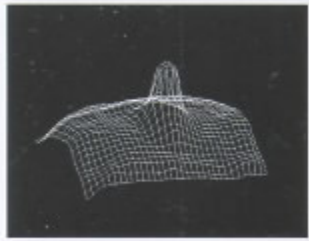

Fig. 61

XXVI. EXPOSURE METERING USER SETTING MODE

This camera has 2 types of exposure metering systems: center-weighted average metering and spot metering. Choose the appropriate metering system according to the situation or subject you are shooting.

Center-weighted average metering This system measures the viewing area, emphasizing the center portion. This metering system is ideal for general shooting and landscape shooting. (Fig. 60)

Spot metering This system only measures the central spot (inside the microprism area). This metering system is effective when there is a wide contrast between the subject and the background, or when you wish to emphasize a section of the subject (i.e., portrait shooting in backlit conditions, subjects on a stage, etc.). (Fig. 61)

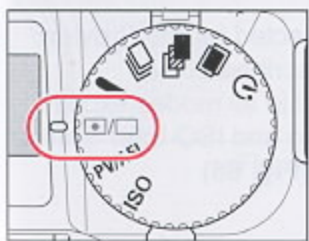

Fig. 62

1. Turn the mode dial to select  (Exposure Metering User Setting mode). (Fig. 62)

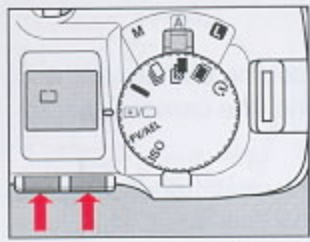

Fig. 63

2. Press the up/down buttons to select either [] (spot 1 metering) or [*] (center-weighted average metering). (Fig. 63)
3. To change the current exposure metering setting, repeat steps 1 and 2 again.

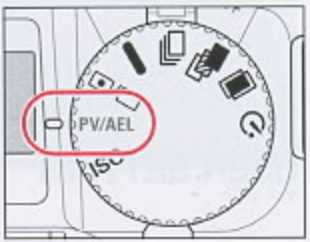

Fig. 64

XXVII. PREVIEW/AE LOCK USER SETTING MODE

The Preview/AE Lock User Setting mode allows setting for the Preview mode or the AE Lock mode. The Preview mode enables the preview of the depth of field for the selected aperture. The AE Lock mode locks the exposure value for precise exposure metering.

1. Turn the mode dial to select PV/AEL (Preview/AE Lock User Setting mode). (Fig. 64)

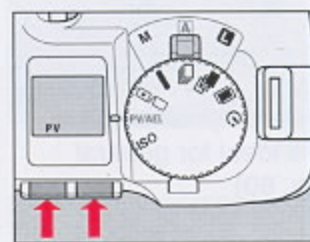

Fig. 65

2. Press the up/down buttons to select either PV (Preview) or AEL (AE Lock). (Fig. 65) To change the current Preview/AE Lock setting, repeat steps 1 and 2 again.

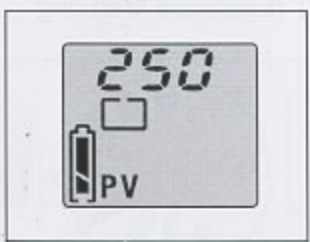

Fig. 66

Preview

Normally, the image seen through the viewfinder is an image with the aperture open. The Preview mode sets the actual aperture you have selected allowing you to confirm the depth of field of the image.

1. Make sure that PV (Preview) is selected for the Preview/ AE Lock User Setting mode as described above. "PV" is displayed on the LCD panel in all modes except the Exposure Metering User Setting and ISO User Setting modes when Preview is selected. (Fig. 66)

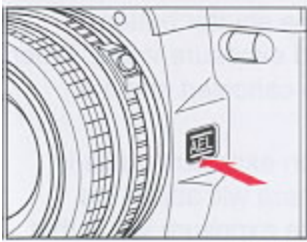

Fig. 67

2. While looking through the viewfinder, press the preview/ AE lock button. (Fig. 67)

- The aperture will be set to the aperture opening you have selected and you can confirm the areas that are focused.
- The viewfinder image will darken when the Preview/AE lock button is pressed.

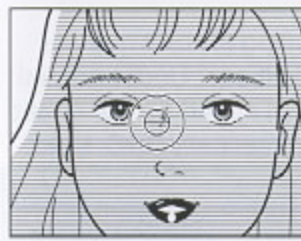

Fig. 68

AE Lock

The AE Lock mode locks the exposure value for precise exposure metering. With the AE Lock mode, you can precisely meter a subject detail that is not located in the center of the viewfinder, and cope with high-contrast subjects and backlit situations when used in combination with exposure compensation.

- If you cannot get close to the subject, it is recommended that the Exposure Metering User Setting mode be set to spot metering for optimum AE lock results.

1. Make sure that AEL (AK Lock) is selected for the Preview/ AE Lock User Setting mode as described above.. "AEL" is displayed on the LCD panel in all modes except the Exposure Metering User Setting and ISO User Setting modes when AE lock is selected.

2. Bring the camera as close to the subject as necessary so that the exposure will not be affected by the background. (Fig. 68)

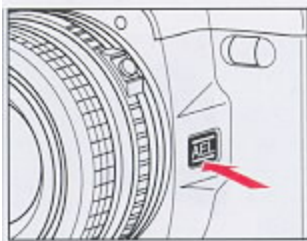

Fig. 69

- If the LCD panel is not operating, press the shutter button halfway and the display will appear. The mode cannot be set when the LCD panel is not operating.

3. Press the Preview/AE lock button. (Fig. 69) The exposure value is locked. The "AEL" mark flashes in the viewfinder display and "AEL" remains lit on the LCD panel in all modes except the Exposure Metering User Setting and ISO User Setting modes.

4. Compose your picture and press the shutter button.

The picture is taken with the locked exposure value. When the picture is taken, AE lock will be canceled and the "AEL" mark will disappear.

- If the aperture is changed while an exposure value is locked in Auto operation, the camera will adjust the shutter speed to correspond to the exposure value that is locked.

· To cancel AE lock before releasing the shutter, press the preview/AE lock button again or set the main switch selector to L (Lock) to turn off the power.

· If the preview/AE lock button is kept pressed while shooting, it is possible to shoot repeatedly with the locked exposure value.

XXVIII. ISO USER SETTING MODE

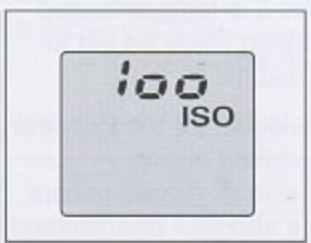
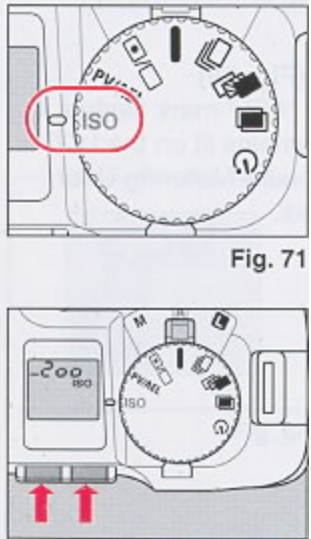
 <p>Fig. 70</p>	<p>The ISO User Setting mode is set when "ISO" is displayed on the LCD panel. (Fig. 70)</p> <p>The ISO User Setting mode allows setting for ISO manual override of the film for advanced applications. Under normal conditions, the camera sets the ISO film speed for DX-coded films ranging from ISO 25 to 5000 automatically (ISO 12 to 6400 for manual override setting).</p> <p>The manual ISO setting has priority over the automatic DX coded setting.</p> <p>This mode is used to set the film speed for non-Ding films, or to set a different film speed than that specified for DX-coded films.</p>
 <p>Fig. 71</p> <p>Fig. 72</p>	<ol style="list-style-type: none">1. Turn the mode dial to select ISO (ISO User Setting mode). (Fig. 71)2. Press the up/down buttons to set the desired film speed. (Fig. 72) <ul style="list-style-type: none">· The exposure difference between the automatic DXcoded setting and the manual override film speed setting is indicated by the "+" and "-".· The film speed you have set will be displayed for about 2 seconds when the main switch selector is set to A (Auto) or M (Manual), and when the film is loaded.· Non-DX films must be set manually. If not, the film will be set to the default 100 film speed setting.

XXIX. EXPOSURE COMPENSATION



Exposure compensation is applicable for the Self-timer mode, Multi Exposure mode, Auto Bracketing mode, Continuous Shooting mode and Normal mode in Auto operation only. For more information, refer to "Up/Down Buttons Operations" on page 5. When there is excessive contrast between the subject and the background, the subject may be underexposed (dark) or overexposed (light). When this occurs, or when you cannot bring the camera close to the subject, exposure compensation can be used. (Use the AE lock when you can bring the camera close to the subject. Refer to page 31.) Also, an image may come out gray when white or black is dominant. The light and dark colors of your picture can be shot correctly by using this mode. You can also shoot underexposed or overexposed pictures intentionally. Exposure compensation can be set within the range of ± 4.0 EV in 0.5 EV increments

- Naturally, exposure compensation cannot be set in Manual operation because the desired compensation can be deliberately selected by looking at the exposure indicator when setting the aperture and shutter speed.

Shooting in Backlit Conditions In backlit conditions the subject will be underexposed because of the very bright background. Set the exposure compensation to a plus (+) value depending on the lighting conditions.



Dominantly White Subjects

If a dominantly white subject is photographed, it will be underexposed and appear dark. In addition, white areas will turn out gray. Set the exposure compensation to a plus (+) value depending on the lighting conditions.



- 1.0 EV

Dominantly Dark-colored Subjects

If a dominantly dark-colored subject is shot, the whole image will be overexposed, making the subject light (white) and dark-colored areas will come out gray. Set the exposure compensation to a minus (-) value depending on the lighting conditions.

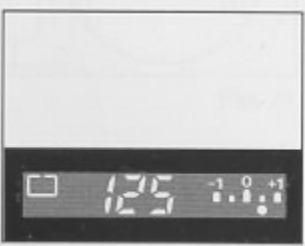

Fig. 73

· When the exposure indicator is displayed in the viewfinder display as shown in the illustration, the exposure compensation is set. The exposure indicator displays the selected exposure compensation value. (Fig. 73) The LCD panel displays the exposure compensation value also. Press the shutter button halfway and press the up/down button to display the exposure indicator in the viewfinder display and the exposure compensation value on the LCD panel.

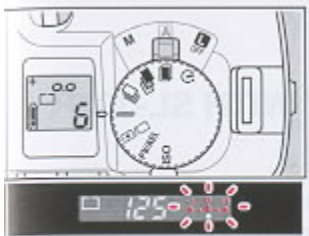

Fig. 74

1. Press the up/down buttons until the exposure indicator is displayed. (Fig. 74) The exposure indicator is displayed in the viewfinder display. The exposure compensation value is displayed on the LCD panel also.

· The exposure indicator appears flashing in the viewfinder display. This allows you to set the exposure compensation while looking through the viewfinder.

· If you do not make any changes (i.e., exposure compensation remains set to 0 EV) within 5 seconds after pressing the up/down buttons, the exposure indicator in the viewfinder display will disappear. If you are adjusting a previous exposure compensation value, the exposure indicator will remain in the viewfinder display.

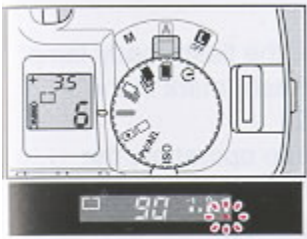

Fig. 75

2. Press the up/down buttons to set the desired exposure compensation value. Each time the up or down button is pressed, the exposure compensation value increases or decreases in 0.5 EV increments. Press and hold down the up or down button to increase or decrease the exposure compensation value continuously within the range of +4 EV in 0.5 EV increments.

- The dot (A) of the exposure indicator flashes when the exposure compensation exceeds +1 EV or -1 EV. (Fig. 75)
- When you have finished shooting with exposure compensation, be sure to restore the exposure compensation value to 0 EV.

FLASH PHOTOGRAPHY

XXX. FLASH PHOTOGRAPHY WITH SL-303P, SL-403P

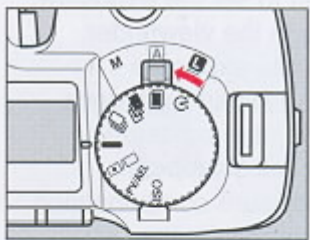

Fig. 76

When you use any of the above Ricoh dedicated flash systems, you can enjoy flash photography.*

1. Set the flash unit to "A" and set the main switch selector to A (Auto). (Fig. 76)

2. Set the lens aperture to the aperture value designated by the flash unit according to the ISO setting of your camera

- Be sure to stay within the recommended flash range for the speed of the film you are using. If you are too close to the subject, your pictures may look too light; if you are beyond the maximum distance, your pictures may look too dark

3. When the flash unit is fully charged, the flash-ready lamp on the flash unit lights and the ~ (Flash) mark in the viewfinder display appears. (Fig. 77)

When the flash unit is charged in Auto operation, the shutter speed is set to 1/100 automatically.

- The subject may be overexposed when "100" flashes in the viewfinder display.

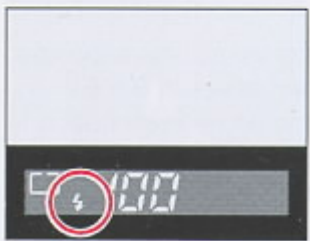

Fig. 77

4. Press the shutter button.

· Make sure that the camera is not perpendicular to reflective backgrounds such as mirrors or other shiny surfaces. The flash will be reflected back to the camera and cause a bright glare spot in your picture. The reflected glare may also cause underexposure. Take pictures at an angle to shiny surfaces to minimize flash reflections.

· For manual flash photography, slide the switch lever of the flash unit to "M", and set the shutter speed between L32 to 90. (If the shutter speed is set between 1/125 - 1/2000, the shutter speed will be set to 1/100 automatically.) The user-selected shutter speed flashes on the LCD panel, and "100" appears in the viewfinder display. The dot (A) of the exposure indicator below +1 flashes in the viewfinder display for manual flash photography.

For Ricoh SL-323, follow the instructions for "FLASH PHOTOGRAPHY WITH FLASH UNITS OTHER THAN RICOH".

XXXI. FLASH PHOTOGRAPHY WITH FLASH UNITS OTHER THAN RICOH

1. Set the flash unit to Auto mode and set the shutter speed below 1/90.
2. Set the lens aperture to the aperture value designated by the flash unit according to the ISO setting of your camera.

OTHERS

XXXII. INFRARED FILM (as of 2022 there is new IR film. But there are Digital IR cameras as a better choice.

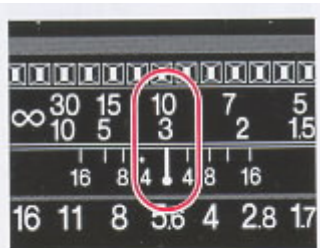

Fig. 78

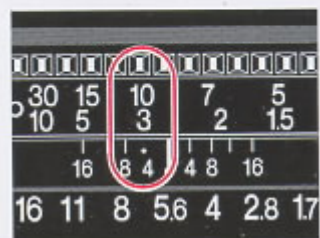

Fig. 79

Always readjust your focus to the infrared focusing mark when using infrared films and infrared filters. This is necessary because the infrared rays have longer wave lengths than the visible light rays you see and focus with, and the camera lens focuses them slightly further back inside the camera. Therefore visual focusing cannot be accurate without adjustment.

1. Attach the infrared filter and focus on the subject. Read the indicated distance off the lens barrel. (Fig. 78)
2. Shift that distance setting over to the red infrared index mark. Set the exposure in accordance with the instructions for the film. (Fig. 79)

(webmaster: If you want IR images, go digital. There are many options available.

XXXIII. DIOPTRIC LENSES

The viewfinder eyepiece has a built-in -1 correction lens (suitable for most normal vision). If a dioptic lens is fitted, you would not have to wear eyeglasses when taking pictures. Slip the lens in the groove of the viewfinder eyepiece. Dioptic lenses are available in 7 types: -4, -3, -2, -1, +1, +2 and +3.

· Some forms of astigmatism, etc., may make dioptic eyepiece correction not possible. Please check with your optician for a recommendation based on your prescription.

XXXIII. INTERCHANGEABLE VIEWFINDER SCREENS

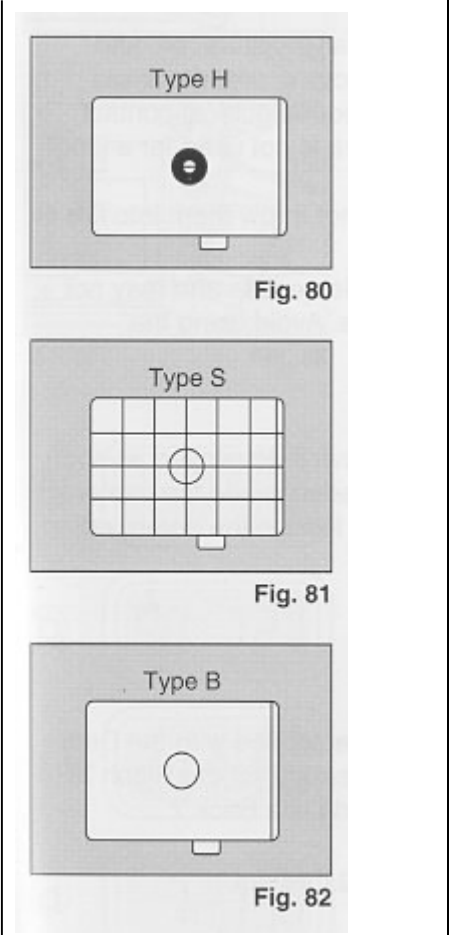
 <p>Type H Fig. 80</p> <p>Type S Fig. 81</p> <p>Type B Fig. 82</p>	<p>Ricoh offers a choice of 3 viewfinder screens to suit your needs or preference. Each features Ricoh's Acu-Bright mat for optimum brightness and easier focusing in dim light.</p> <p><u>Horizontal Split Type Screen (MH type)</u> This screen is normally installed. Recommended for general shooting. (Fig. 80)</p> <p><u>Grid Matte Type Screen (MS type)</u> A matte screen with horizontal and vertical lines. This screen facilitates composition of your photograph. (Fig. 81)</p> <p><u>All Matte Type Screen (MB type)</u> For general shooting and close-up photography. Also recommended when focusing is difficult with a split image. (Fig. 82)</p>
---	---

XXXV. RELEASE SWITCH

By using the separately sold release switch, the shutter can be released from a distance.

1. Set the main switch selector to L (Lock) to turn off the power.

· The shutter may release if the release cable is connected to the camera when the power is on.

2. Connect the release switch to the remote control socket of the camera.

3. Set the main switch selector to A (Auto) or M (Manual).

4. Press the release switch to shoot.

XXXVI. CARE OF BATTERIES

- This camera is equipped with precision electronic parts. To ensure optimum performance, use high quality alkaline batteries.
- The capacity of the batteries depends on the brand and type of batteries used.
- Before installing, be sure to clean all moisture, oil, and grease off all battery contact surfaces in order to avoid future problems of corrosion and poor electrical contact.
- Remove batteries when the camera is not used for a long period of time.
- Dispose of batteries properly. Do not throw them into fire or expose to high temperature.
- In cold conditions, battery power decreases and may not be sufficient to operate the camera. Avoid using the camera in low temperatures.

Notes on Film

- Use a loaded film promptly and have it developed as soon as it is removed. Leaving a film loaded inside the camera for an extended period of time will lead to the deterioration of the film, etc.

XXXVII. DATA BACK 7

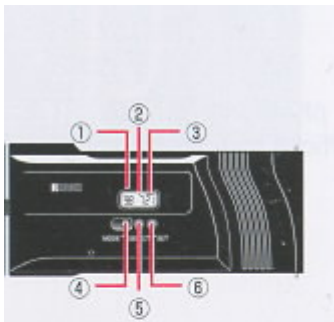

Fig. 83

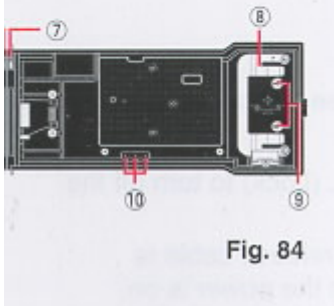

Fig. 84

The Ricoh XR-X3000D is standard equipped with the Data Back 7. To use the date imprinting feature for the Ricoh XR-X3000, purchase the separately sold Data Back 7.

Nomenclature of the Date Imprinting Feature

(Fig. 83, 84)

- (1) Display Panel
- (2) Month Indication (M)
- (3) imprint Mark (_)
- (4) Mode Button
- (5) Select Button
- (6) Set Button
- (7) Locating Pin (Connecting pin)
- (8) Battery Cover
- (9) Battery Cover Retaining Screws
- (10) Data Back Contacts

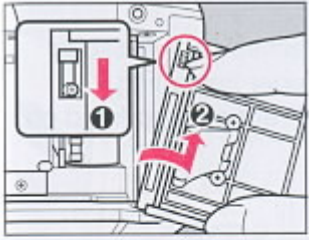

Fig. 85

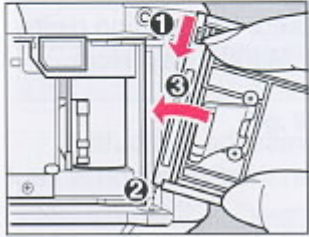
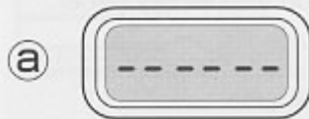

Fig. 86

Attaching the Data Back 7

1. Open the back cover and push down the release pin on the back cover to remove. (Fig. 85)
 2. Attach the Data Back 7 to the camera while pushing down the release pin on the Data Back 7. (Fig. 86)
- To remove the Data Back 7, follow the same instruction in step 1.



Selecting the Imprinting Mode

Each time the Mode button is pressed, the display changes as shown below.

<Examples of Date Imprinting>

Date imprinting can be divided into five types: date, time, and no imprinting.

(a) No imprinting

(b) Date (Year/Month/Day)
1998 July 21st

(c) Time (Day/Hour/Minute)
21st 15:59

(d) Date (Month/Day/Year)
July 21st, 1998

(e) Date (Day/Month/Year)
21 st July, 1998



Fig. 87

Date Imprinting Location

Date imprinting appears on the lower right hand corner of the photograph. (Fig. 87)

Checking Imprinting

After shooting, the imprint mark -- flashes on the display panel for a few seconds to confirm proper imprinting. The imprint mark -- and the letter "M" are not imprinted on the photograph.

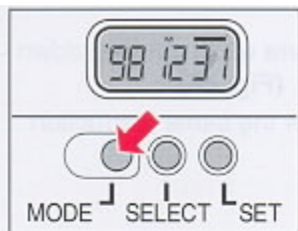

Fig. 88

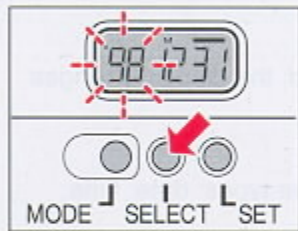

Fig. 89

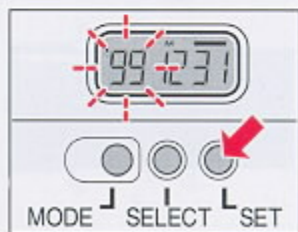

Fig. 90

Resetting the Date and Time (Fig. 88, 89, 90)

1. Each time the Select button is pressed, the flashing digits change in the following order: Year, Month, Day, Hour, Minute and Colon (:).
2. When the digits to be reset flash, press the Set button until the desired digits appear. When the Set button is kept pressed, the digits change rapidly.
3. Imprinting is not possible while the Data Back is being reset. When resetting is complete, press the Mode button until the imprint mark _ appears on the display panel.

Accurately Setting the Seconds

1. Press the Mode button to display the time (Day/Hour/ Minute).
2. Press the Select button so that the colon (:) flashes.
3. Press the Set button accordingly to set the seconds to 0.
4. Press the Mode button.

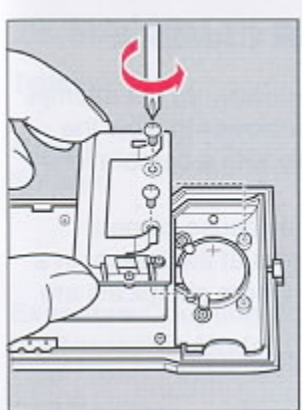

Fig. 91

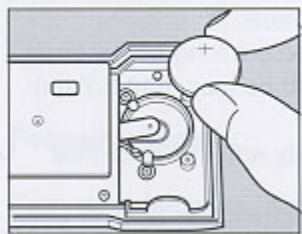

Fig. 92

Battery Replacement

1. Open the back cover.
2. Remove the battery cover retaining screws from the Data Back battery cover with a small (+) or (-) screwdriver.

Remove the battery cover. (Fig. 91)

3. Remove the battery.
4. Load the new battery with the side marked (+) facing upwards. Then, close the battery cover using the (+) or (-) screwdriver. (Use lithium battery CR2025. The service life is about 3 years.) (Fig. 92)

- When the battery is exhausted, the imprinted digits become faint. At that time, replace the battery.

- Do not open the battery cover except when replacing the battery.

- Keep the battery out of reach of children. If a child swallows the battery, contact your doctor immediately.

Notes on Date Imprinting Feature

- At temperatures below 0°C (32° F), the battery performance deteriorates. The date imprinting feature may not function correctly and imprinting may become impossible.

- When the battery is replaced, the display panel sometimes shows the wrong digits. Reset the digits for correct indication.

- The date is sometimes illegible if it is imprinted on the following objects.

(1) "Warm" colored objects, such as red, yellow, orange, etc.

(2) Objects with details similar in size to the imprinted date (gravel, leaves, etc.)

(3) Objects of high luminance (sky, white wall, etc.)

- Imprinting is not possible in the following modes. (1) Print Off mode (2) Reset mode

XXXVIII. PROPER CARE OF YOUR CAMERA

- If there is dirt on the lens or mirror surface, do not attempt to remove it with your fingers. Use a blower to blow the dust away, or wipe the surface gently with a camera lens tissue or a soft cloth.
- Excessive shock, humidity or salt may cause camera malfunction. When you use the camera at the beach, in a corrosive atmosphere, or in a place where chemicals are used, wipe it off carefully.
- Do not expose the camera and film to extreme temperatures.
- Do not leave your camera in your car at the beach, in the desert, or in other extremely high temperature conditions to prevent possible damage to the camera.
- When using a tripod, do not try to force a long screw into the socket. (The screw length should be less than 5.7 mm (1 / 4).
- Store the camera away from humidity and in a dust-free place.
- This camera is not waterproof. If it comes into contact with any kind of liquid (i.e., water, rain, drink, etc.), the electrical and metal parts will rust and cause damage to the camera. Contact a Ricoh Camera Service Center if your camera has been exposed to any liquid.
- Take care not to expose the camera to sudden changes in temperature, as this may cause condensation on the lens, film, or inside the camera which may lead to the malfunction of the camera.
- Do not place the camera near equipment that has strong magnetic fields such as a television or radio.

XXXIX. MAJOR SPECIFICATIONS .

Type: 35mm SLR camera with focal plane shutter, Automatic and Manual exposure controls

Mount: Ricoh system K mount

Shutter: Electronically controlled, vertically moving focal plane shutter;

Automatic: 1/2000 sec.-32 sec.

Manual: 1/2000 sec.-32 sec., Bulb

Exposure Coupling Range: EV 0-18 (ISO 100 with standard F1.4 lens)

Photographic Modes: Aperture-priority automatic exposure mode Manual exposure mode

Self-timer: Electronically operated 10 sec. delay with LED indicator

Viewfinder: Field of view: 91% horizontally and vertically Magnification: 0.80x (with 50mm standard lens)

Finder display: AE lock, exposure indicator, flash mark, exposure metering modes, shutter speed, bulb, and Manual operation

Focusing Screen: Interchangeable type, horizontal split-image spot in microprism band surrounded by mat.

Exposure Metering System: Two selectable TTL full open metering systems

(1) Center-weighted average metering (LV 0-LV 18.0: F1.4 lens)

(2) Spot metering (LV 4.0-LV 18.0: F1.4 lens)

Sync Speed: 1/100 sec.

Exposure Compensation: +4 EV

Flash Contact: Hot shoe

Film Loading: Ricoh Auto-load system, automatic 1 st frame setting

Film Advance: Automatic with a built-in motor, two selectable modes:

Normal (single) and Continuous Shooting (approx. 0.7 sec./frame)

Film Rewind: Automatic rewind at the end of film, manual rewind possible, film can be rewound so that a portion of the film leader protrudes from the film cassette

ISO Setting: ISO 25-5000 DX-coded,

ISO 12-6400 Manual (Manual override possible)

Preview: - Electronic preview button

Remote Control: Remote control socket

Automatic Bracket Mode: +0.5 EV

Back Cover: Removable (Data Back 7 or Data Back 3 for date imprinting)

LCD Display: Exposure counter, ISO, battery indicator, shutter speed, center-weighted average/spot metering mark, time for bulb, remaining seconds for self-timer, AEL (AK Lock), PV (Preview), exposure compensation value (+4.0 EV in 0.5 EV steps)

Main Switch Selector:

(1) L (Lock)

(2) A (Auto)

(3) M (Manual)

Mode Dial: (1) Self-timer

(2) Multi Exposure

(3) Auto Bracketing

(4) Continuous Shooting

(5) Normal

(6) Exposure Metering User Setting

(7) Preview/AE Lock User Setting

(8) ISO User Setting

Power Source: Four alkaline batteries

Dimensions: Approx. 151 x 94.5 x 62 mm/ 5.9 x 3.7 x 2.4 inches (WxHxD)

Mass Weight: Approx. 480 g/17 oz. without batteries