

Kiev-4M & 4AM

posted 3-7-'04

This camera manual library is for reference and historical purposes, all rights reserved.

This page is copyright© by mike@butkus.org, M. Butkus, NJ.

This page may not be sold or distributed without the expressed permission of the producer
I have no connection with any camera company

On-line camera manual library

This is the full text and images from the manual.

If you find this manual useful, how about a donation of \$3 to:

M. Butkus, 29 Lake Ave., High Bridge, NJ 08829-1701

and send your e-mail address so I can thank you.

**Most other places would charge you \$7.50 for a electronic copy
or \$18.00 for a hard to read Xerox copy.**

This will help me to continue to host this site, buy new manuals, and pay their shipping costs.

It'll make you feel better, won't it?

If you use Pay Pal, use the link below. Use the above address for a check, M.O. or cash.

Venmo is @mike-butkus-camera



www.PayPal.me/butkus

[Back to main camera manual page](#)



INTRODUCTION

Cameras "KIEV" have been produced since 1947 at Arsenal plant (the city of Kiev, Soviet Union). It was just a copies of Zeiss Contax cameras. High reliability, excellent optics, capability to shoot at low temperature (it can work in Russian winters!), presence of exchangeable lens - these are the conditions defined the usage of these cameras for professional shooting during the past 40 years.

The cameras with index "M" is slightly improved in comparison with old models: Easier using the head for changing shutter speeds, a standard "hot shoe" for use with normal flash connections, film rewind head with a crank, the lens "Helios-104" 1.8:50mm with better resolution than old Jupiter-8M 2.0:50mm.

1. SPECIFICATIONS

Type of Camera

Mechanical rangefinder camera. Designed for amateur photography, but can be used for scientific and technical photography as well. Picture Format 24 x 36 mm. The camera accepts standard 35mm film. Loading the camera with a 1.6 metre length of film will yield 36 exposures.

Shutter

The Kiev camera has an originally designed metal focal plane shutter with vertical traverse. Shutter Speeds Automatically timed shutter speeds 1/2, 1/5, 1/10, 1/25, 1/50, 1/125, 1/250, 1/500, and 1/1000, plus "B" for manually-timed long exposures.

Lens

"Helios-103" (or "Jupiter-8M"). High quality anastigmat with high resolution. The lenses are finished with an anti-reflection coating. Focal length = 50mm with maximum opening of 1:1.8 (or 1:2 for Jupiter-8M). Supplied as the standard lens for the camera.

Lens Mount

Bayonet mount, similar to Contax rangefinder bayonet mount.

Viewfinder

Built-in optical viewfinder gives the field for the standard 50mm lens. Magnification, 0.8X life size. When using other lenses of different focal lengths, the use of an auxiliary finder (i.e, "universal viewfinder") is necessary due to the fact the image will be enlarged on the negative but not in the viewfinder.

Focusing

The camera is equipped with a long base optical rangefinder, working from 0.9 m to infinity. The long base rangefinder provides high focusing accuracy, essential with large aperture or long focal length lenses. Focusing is also possible with the use of the distance scale.

Self-timer

Mechanically controlled, 9-15 second exposure delay.

Exposure Metering

Built-in selenium cell exposure meter (for Kiev4M only). Reading angle is 65 to 70 degrees. Acceptable brightness range is 4 to 16000 cd/m². Kiev-4AM do not have a built-in exposure meter. Only manually selected film-speed indication only.

Filters

Threaded, 40.5 x 0.7 mm.

Tripod

1/4" threaded socket.

Flash Synchronisation

1/25 or slower with electronic or bulb flash.

2. NOMENCLATURE

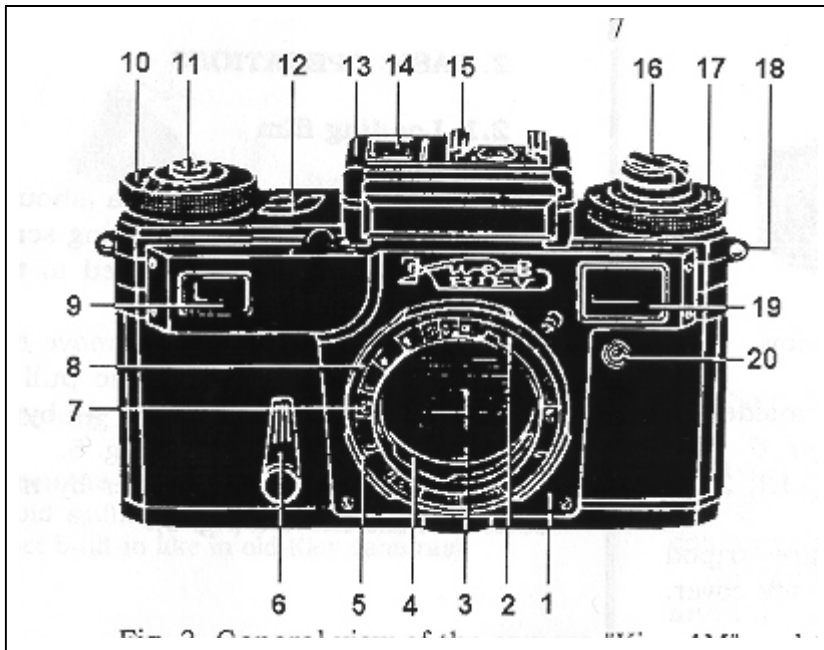

The basic components of the camera (fig.3) are: shutter, lens, rangefinder, viewfinder, self-timer mechanism mounted on the body, and removable back cover. Shutter cocking is by turning the winding knob 10. The shutter speed scale is engraved on the winding knob. The scale has numbers 2, 5, 10, up to 1000, which stands for 1/2, 1/5, 1 / 10, 1 / 1000 sec., respectively. The shutter mechanism is linked to the film transport and frame counter mechanisms.

By turning the winding knob 10, the shutter is simultaneously cocked, with the frame advance and the of the disc counter moves up by one division. With this design, double exposures are prevented.

The shutter is released by the release button 11 or by activating the self timer release 49. The shutter release button has a threaded hole to accommodate a shutter release cable.

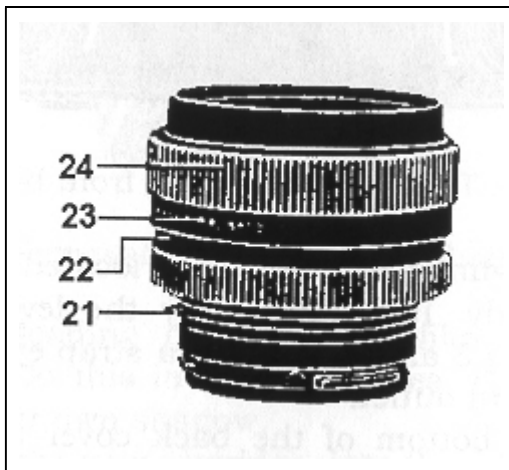

Focusing consists of coinciding the second image from right window 9 and left window 19 into one, which is made possible by an optical compensator in the rangefinder mechanism.

The rangefinder mechanism is connected to the lens focusing mechanism, and thus, when the rangefinder images coincide, the lens is focused correctly. The compensator turns by rotating the gear wheel 34.

A distance scale 7 is engraved on the lens focusing mount, graded from 0.9 to infinity (fig. 4). All numbers represent distances in meters.

The lens mount is locked (and consequently, the lens) by lever 2.

The depth-of-field scale 8 is engraved on the fixed portion of the lens focus mount. This scale shows the areas of sharpness depending on distance and chosen aperture.

Note: With the Kiev, distances are measured from the film plane to the subject.

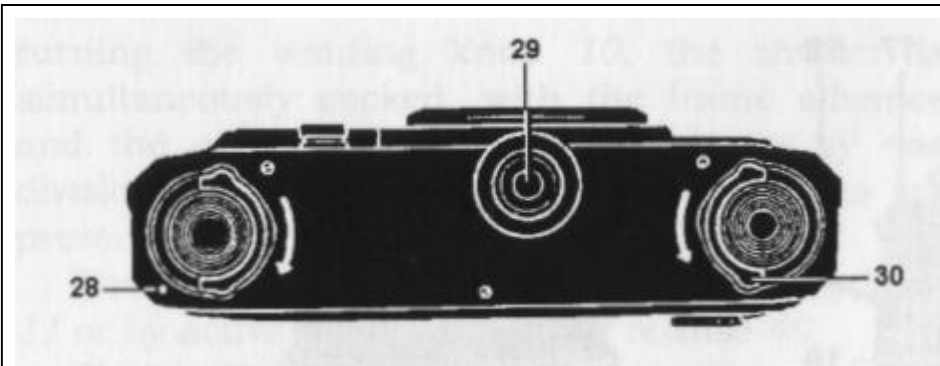

Fig. 4. The camera as seen from below.

The rewind knob **16** is for rewinding exposed film back to its cassette.

The self-timer mechanism is located inside the camera body. It is started by the lever **6**. Also shown in fig 3 are: **18**- camera strap eyelet; **20** - flash PC cord outlet.

On the bottom of the back cover are: tripod socket **29**, lock keys **28** for locking the back cover, and film rewind index **30** (fig. 4).

2. BASIC OPERATIONS

2.1. Loading film

Before loading, the camera should be taken from its case. Unscrew the locking screw found on the bottom of the case, fastened to tripod socket **29** (fig.4).

To open the camera and remove the cartridge, turn the camera bottom up and pull out the lock keys **28** and twist them (fig. 4) by half a turn against the stop as shown in fig. 5.

Then remove a back cover by moving it to a bottom of the camera (fig. 6).

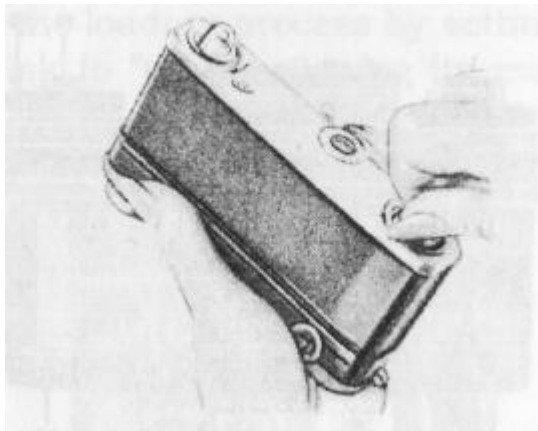

Fig. 5. Opening the locks on the back cover.



Fig.6. Removal and closing of a back cover.

Note: Don't open the camera back with the camera lens side up to avoid spilling the film cartridge and take-up spool (if it is not built-in like in old Kiev cameras).

Avoid loading or unloading film in bright sunlight. Do this in a shaded area, or under the cast of your own shadow.

Install the new cartridge into the left chamber, and the take-up spool in the right chamber.

Fix the tip of the film leader into the take-up spool. The film perforations should engage into the sprocket teeth of the transport drum (fig. 7).

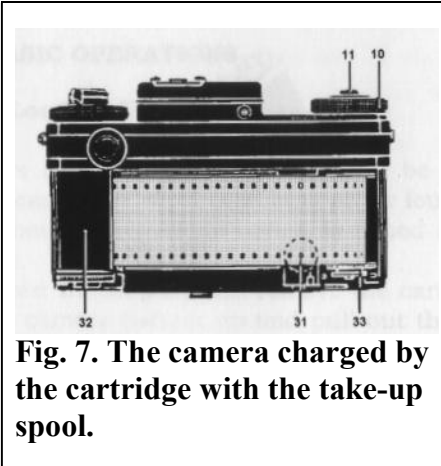

Fig. 7. The camera charged by the cartridge with the take-up spool.

Close the camera back. This has to be made in reverse of the opening sequence. Replace the back cover so that its edges engage with the grooves of the camera body. Hold the edges of the film, push the back cover in, and turn the locking keys against the stop and fold them back.

Make 2 blank exposures (the first two frames are on the exposed end of the film). Turn the rewind knob **16** to the direction of its engraved arrow to make the film taut.

If the camera is loaded properly, turning the advance knob **10** will cause the rewind knob **16** to turn in the direction opposite its engraved arrow.

A stationary rewind knob will indicate either an improperly loaded film or a loosely wound film in the cartridge or the take-up spool.

Finish the loading process by setting the frame counter disk to "0" by turning its moveable part **34** (fig. 8).

2.2. Basic shooting

The process of shooting consists of the following operations:

1. Determination of appropriate aperture and shutter speed;
1. Shutter cocking;
2. Selection of shutter speed;
3. Selection of aperture;
4. Focusing;
5. Composing;
6. Release of shutter.

2.2.1. Determination of appropriate shutter speed and aperture

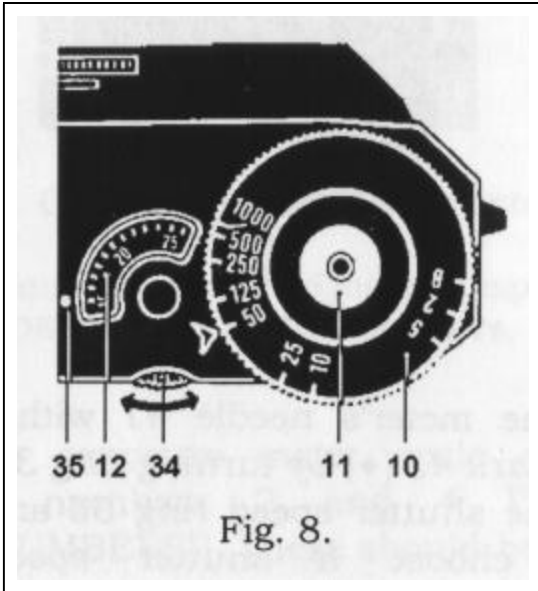

With the Kiev-4M, the appropriate shutter speed and aperture for correct exposure can be determined through its built-in exposure meter.

Turn film speed ring **37** so that the speed value (ROCR) of the film in use aligns with index marker (38, figure 9). The ROCR Soviet standard is almost the same as ISO/ASA. If the film in use has an exposure index not given on the scale, the index can be set between two specified numbers (e.g., ISO 100 can be set between ROCT 65 and 130).

Aim the camera towards the subject and open the exposure meter cover **40** by pressing button **39** (fig. 10).

Note: Red numbers on ring 36 indicate exposure time in FULL SECONDS, and black numbers, fractions of seconds.



Align the meter's needle 41 with the black diamond mark 43 (,) by turning ring 36.

From the shutter speed ring 36 and aperture ring 37, choose a shutter speed/aperture combination appropriate for the exposure.

Fig. 10. Opening the exposure meter cover.

On the exposure meter scale **42** are the multiplier numbers 2 and 4 ["EXPOSURE FACTOR NUMBERS". These should be used if the needle **41** is not able to reach the index • even after a complete turn of ring **36** (in low light shooting situations). The ring **36** should then be turned so that needle **41** will point to the nearest multiplier number mark. The correct shutter speed is obtained by multiplying the shutter speed value read off the scale **36** with the multiplier number. (For example: A combination of 1/60 @ f:2 is read off the scale, and the meter needle points at "2". The shutter speed should be multiplied by 2, and the correct shutter speed for proper exposure should be 125 [$1/60 \times 2 = 1/125$].

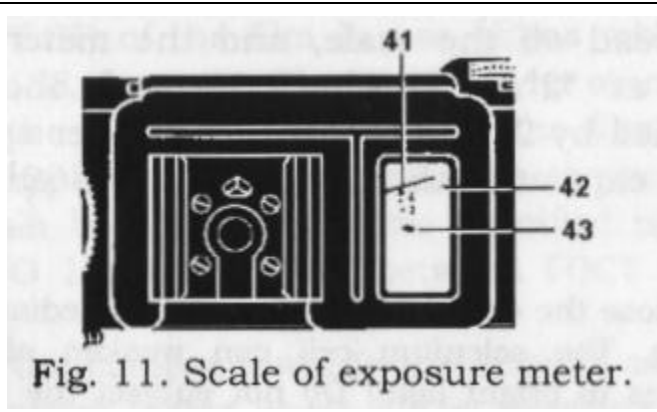
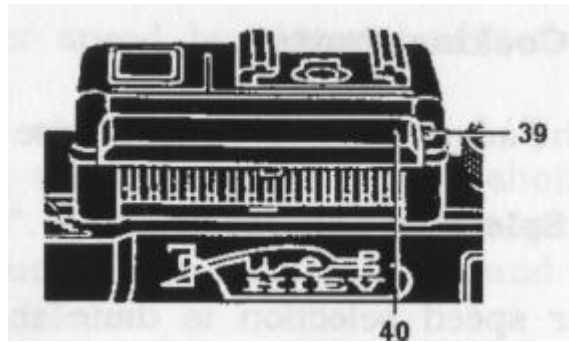

Note: Close the exposure meter cover immediately after metering. The selenium cell can weaken after long exposures to bright light! Do not subject the meter to shock.

For the meterless Kiev-4A, appropriate exposures can be determined by several methods: The best way is through a separate exposure meter. Exposure calculators or tables (as found in film boxes) can also be used. Visual judgement based on one's photographic experience is also useful.

2.2.2. Cocking shutter

Turn the advance knob 10 clockwise (fig. 3)

2.2.3. Selecting shutter speed

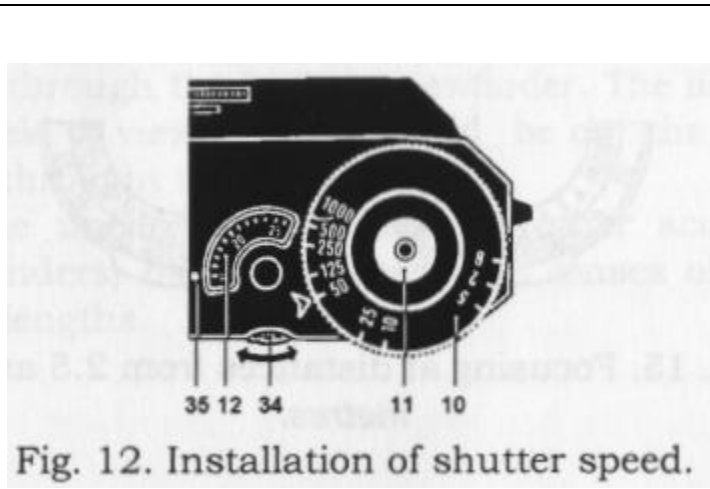

Shutter speed selection is done through the knob **10** as follows:

Raise the knob **10** by the edges (fig. 13), and turn it so that the black dot on the top plate points to the number of the chosen shutter speed, and lower the knob back. The advance knob should be turned clockwise before changing shutter speeds. In this state, the shutter speed can be set more correctly. The shutter speed can be set with the shutter either cocked or fired. However, it is recommended that the shutter speed be changed with the shutter cocked.

If an exposure longer than 1/2 second is necessary, the knob's black point should be set against "B". The shutter will remain open as long as the shutter button is pressed, and will close only upon release.

2.2.4. Setting the aperture

The aperture can be selected by turning ring **23** (fig. 3) and aligning the chosen aperture number against the index mark. The setting should be done before focusing the lens.

2.2.5. Focusing

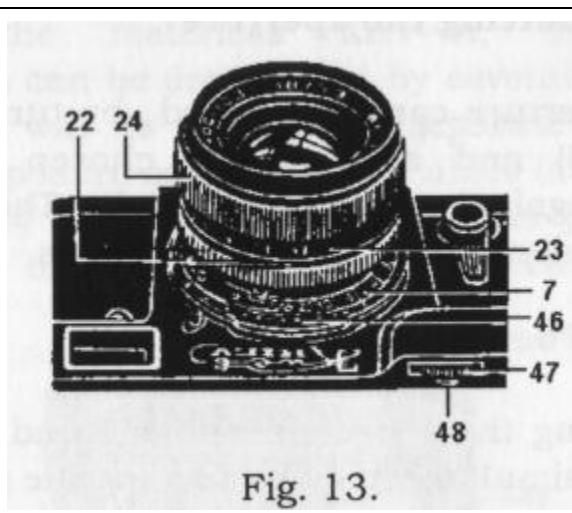

Adjusting the rangefinder image and focusing are made simultaneously by turning the moveable part of the gear focus wheel **48** (fig. 3 & 13)

It is recommended (especially when shooting at short distances) to coincide the two images seen through the rangefinder window, on the centre of the focus field patch, rather than the edges. It will ensure more precise focusing (fig. 14).

In situations when the use of the rangefinder is impractical (e.g., fast-moving objects, objects without sharp contours, or dim light shooting), focusing can be done by using the distance scale **20** (fig. 13 & 15).

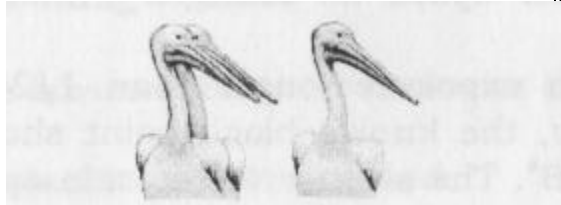

Fig. 14. Coincident Images.



Fig. 15. Focusing at distances from 2.5 and 4 metres.

Shooting without the rangefinder (visual estimation of distances) can be done successfully only at small apertures, i.e., when focus errors are compensated by depth of field.

2.2.6. Composing

Composing the image with a 50mm lens is done through the built-in viewfinder. The limits of the field of view as what would be on the film is seen through the eyepiece.

The universal viewfinder (or other accessory viewfinders) has to be used with lenses of other focal lengths.

2.2.7. Shutter release

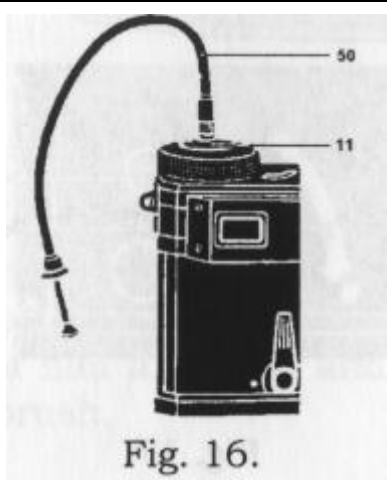

Fig. 16.

The shutter is fired by pressing the shutter release button **11** (fig.3 & 16).

It is necessary to press the button smoothly and gently, so as not to jerk the camera during exposure.

To prevent blurred pictures, the camera must be used with a tripod (or any suitable support) and a cable release **50** for exposures longer than 1/25 sec.

Using the Self timer

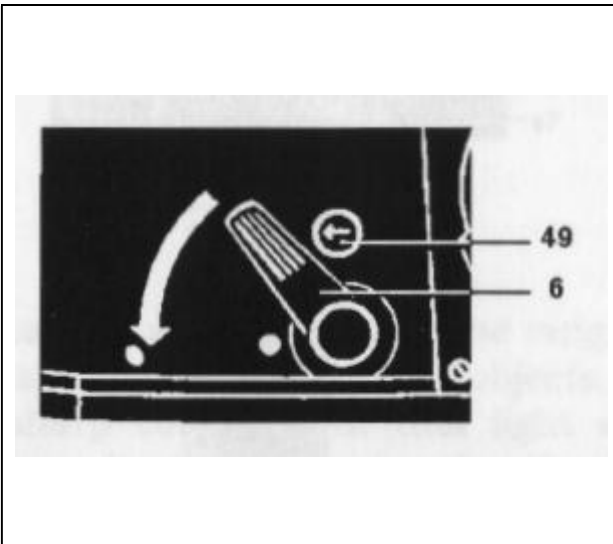

Turn the lever **6** counter clockwise against the stop (fig. 17).

Note: Do not, by any means, turn the self-timer lever further than the pin. When turning, do not press it against the camera body to prevent deformation of the lever and block the pin. When twisted to the left, the self-timer will appear to have a short start and shutter will not fire.

The self-timer delay is between 9 to 15 seconds. It is recommended to first set the shutter speed, and then the self-timer. During the self timer's run, do not change shutter speeds. This can damage the shutter.

2.3. Rewinding film

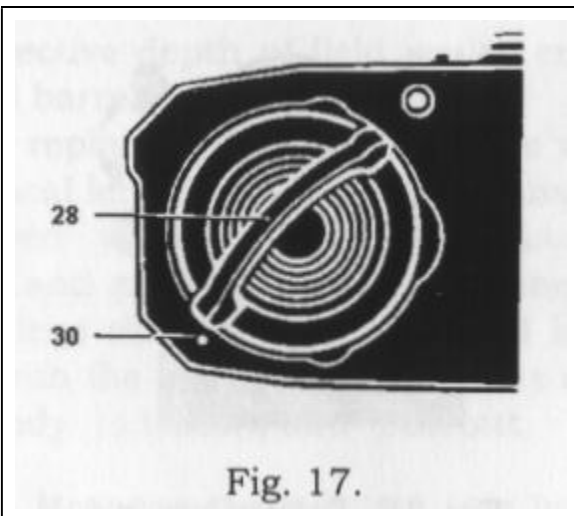

When the frame counter reads "36", it means that the film has reached its end. Stop further shooting and unload the camera (for cartridge to cartridge film loading).

Note: With film lengths shorter than 1.6 metres, the film end is indicated by an increased resistance in winding with the winding knob **10** (fig. 3)



Fig. 18. Return rewind.

Hold the camera with the left hand, cap the lens, turn the lock of back cover **28** and install it opposite red index **30** (fig. 18), and turn the rewind knob **16** (fig. 3) to the direction of its engraved arrow (fig. 18).

Turn the rewind knob until a slight resistance is felt, and finally gone, indicating that the film has been pulled back in to its cartridge.

Then, remove the back cover to take out the cartridge. Before closing the camera, it is recommended to examine its interiors, and check for dust, bits of film and dirt, and remove these with a blower brush.

4. FLASH PHOTOGRAPHY

The camera has a mechanism to synchronise its shutter with flash. Before using flash with the camera, it is recommended to study carefully these instructions.

For mounting flash directly on the camera, there is an accessory shoe 15 and a PC plug outlet 20 (fig. 3). For mounting the flash on the body of the camera there is a accessory shoe 15 and a plug socket 20 (fig. 3). It can be used the flash units with PC cord connector or with "hot shoe" cordless connection.

Flash exposures should only be done at shutter speeds from 1/25 to 1/2 second. The contacts of the synchronization circuit are closed with a fired shutter ("connected"), and when the shutter is cocked, the circuit is open ("off"). It is important to turn the flash on (if connected to the camera) only AFTER cocking the camera, or the flash will fire spontaneously. Cock the shutter immediately or turn off the flash after shooting.

Note: Connect the flash only with the flash switched off, or a cocked shutter.

5. INTERCHANGEABLE LENSES

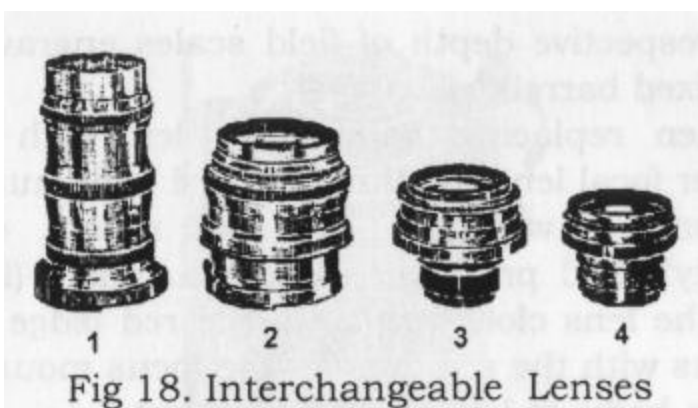

Fig 18. Interchangeable Lenses

The camera is designed to take in other lenses with [Kiev] bayonet mounts (lens specifications are given in the table). The standard lens supplied with the camera is mostly "Helios-103", F=50mm, 1:1.8, but may be replaced with "Jupiter-3", F=50mm 1:1.5, or "Jupiter-8", F=50mm, 1:2. These standard lenses are mounted on the internal ring of the focusing mechanism. All the other lenses mount on the external bayonet, with their respective depth of field scales engraved on their fixed barrels.



Fig. 19. Removing a lens $F = 5 \text{ sm}$.

When replacing the standard lens with lenses of other focal lengths, the standard lens must first be removed with the focusing mount set at "infinity", and press the spring fastener (fig.19). Turn the lens clockwise until the red ledge below it aligns with the red dots on the focus mount and camera body to loosen, and pull out.

Note: Mounting the standard lens the reverse sequence.

Each lens, except the "Jupiter-3" and "Jupiter8" has its own focusing mechanism, distance, and depth of field scales. All lenses focus through the aid of the camera's rangefinder.

Before mounting a lens, remove its rear cap. Both the camera's focusing mount and the lens have to be set at infinity. Put the lens on the bayonet so that the red dot on the lens barrel and the red dot on the camera body coincide. Push in lens and turn counter clockwise until the latch engages and the locks the lens.

Lens is mounted correctly if focusing wheel 47 (fig. 3) turns when lens is turned for focusing.

The lens is removed in a reverse sequence. Set the lens to infinity first, press the lens lock release found near the lens barrel's mount, and turn lens counter clockwise until it disengages with the camera body.

With lenses other than the standard 50 mm, the shot should be composed through the aid of the universal or an auxiliary finder 54. The finder can be mounted on the accessory shoe 15 (fig. 20).

# of item at fig. 18	Lens name	Focal length in sm.
1	Jupiter - 1	13.5
2	Jupiter - 9	8.5
3	Jupiter - 12	3.5
4	Jupiter - 3	5.0
-	Helios-103	5.0
Relative aperture		Resolution in lines in mm, center/edge of frame
1:4		?
1: 2		30/18

1: 2.8	36/ 18
1: 1.5	30/14
1:1.8	55/28

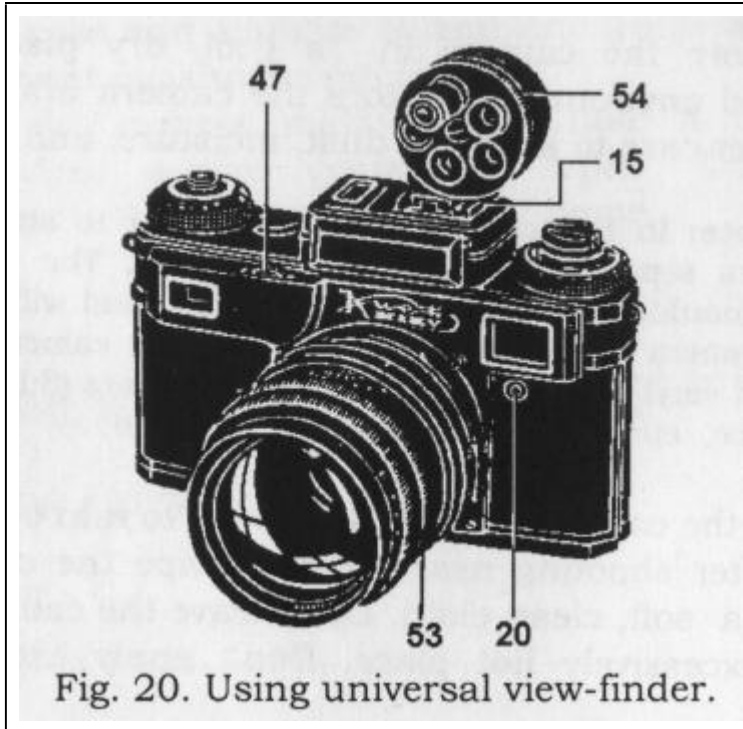

Non-standard lenses are focused by turning their respective front focusing barrels, NOT the focus wheel 47 on the body (fig. 3)

6. CAMERA & LENSES CARE TIPS

Store the camera in a cool, dry place. In humid environments, store the camera inside its leather case to keep out dust, moisture, and salt.

Note: In tropical climates, it is better to store the camera separately from its leather case. The leather case molds quickly in tropical climates, and will cause the camera to mould as well. Storing the camera in a sealed vinyl plastic bag with some desiccants (Silica gel, dry rice, etc) will give it more protection.

If the camera had been exposed to rain or mist, or after shooting near the sea, wipe the camera with a soft, clean cloth. Don't leave the camera in an excessively hot place. Don't apply excessive force during operation. Do not subject the camera to strong shock or impact (especially the Kiev-4).

As mentioned earlier, the lenses have antireflection coated surfaces. Because of its extreme thinness, this coating can be easily abraded with improper wiping or cleaning. To protect the antireflection coatings, the lens surface has to be protected from contamination so that cleaning is less often. Attaching a colorless "Skylight" 1A or UV filter on the lens can give it ample protection. Being colorless, these filters can be permanently left on the lens. The filter will absorb the brunt of contamination, and are easier to clean. Easier and cheaper to replace too, if damaged. Protect the lens from, and do not store it in, a damp environment. Dampness can cause spotting and molding, which will damage the coating.