

Slant/Fin

★ LIBERTY®

OIL-FIRED WATER AND STEAM BOILERS/NO. 2 OIL

INSTALLATION AND OPERATING INSTRUCTIONS

SAFETY WARNING:

KEEP BOILER AREA CLEAR AND FREE FROM COMBUSTIBLE MATERIALS, GASOLINE AND OTHER FLAMMABLE VAPORS AND LIQUIDS. FAILURE TO ADHERE TO ABOVE SAFETY WARNING, MAY RESULT IN PERSONAL INJURY OR DEATH AND PROPERTY DAMAGE.

CONTENTS..... PAGE

Ratings and Dimensions.....	2
Installation Requirements:	
Boiler Location.....	3
Clearances.....	3
Chimney Requirements.....	3
Air Supply and Venting.....	3
Controls and Accessories.....	4
Piping for Steam Boilers.....	4
Blowing Off a Steam Boiler.....	4
Cleaning Piping System.....	5
Piping for Water Units.....	5
Piping for Tankless Heater.....	6
Installing Burner.....	6
Oil Supply Piping.....	6
Wiring the Boiler.....	6
Vent Piping and Draft Regulator.....	6
Operating Instructions:	
Precautions Before Starting.....	6
Start up.....	6
Cleaning and Filling New Water Boiler.....	7
Cleaning and Filling New Steam Boiler.....	7
Low Water Cut-off check-out.....	7
Pressure Control check-out.....	8
Replacement of Steam Boiler.....	8
Wiring Diagrams.....	9-10
Burner Data.....	11-15
Care and Maintenance:	
Extended Shutdown.....	16
Freezing Protection.....	16
Oil Burner.....	16
General Maintenance.....	16

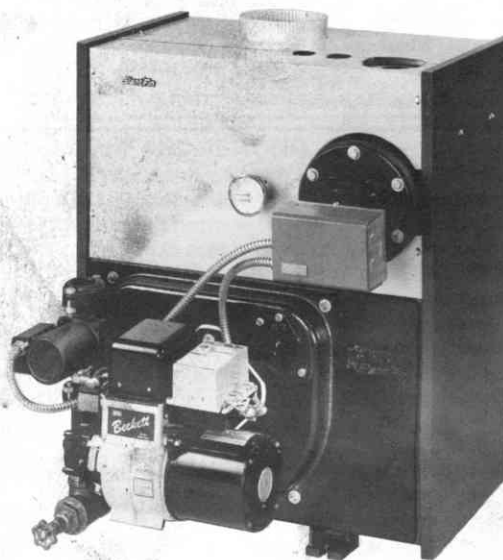

IMPORTANT: The installation of this equipment must conform to the requirements of the authority having jurisdiction or, in the absence of such requirements, to the Installation of Oil Burning Equipment, ANSI/NFPA 31, latest edition, and to the National Electrical Code ANSI/NFPA 70, latest edition. The installation must also conform to the additional requirements in this Slant/Fin Instruction Manual. Where there is any difference, the more stringent requirement shall govern.

In addition, where required by the authority having jurisdiction, the installation must conform to American Society of Mechanical Engineers Safety Code for Controls and Safety Devices for Automatically Fired Boilers, No. CSD-1, latest edition.

THIS MANUAL MUST BE LEFT WITH OWNER AND SHOULD BE HUNG ON OR ADJACENT TO THE BOILER FOR REFERENCE.

IMPORTANT: This boiler must be installed by a trained, experienced, service technician, licensed for the installation and servicing of oil burning equipment or otherwise qualified by the authorities having jurisdiction over the installation.

TAPPINGS AND OPENINGS

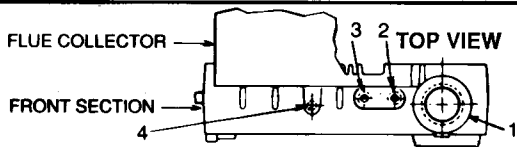

FRONT VIEW WATER

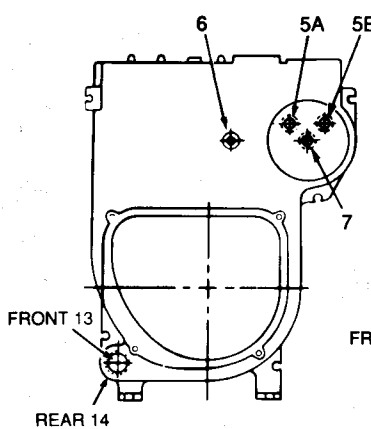

FRONT VIEW STEAM

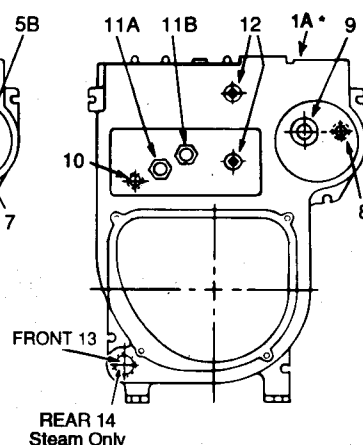

Tapping Loc.	Steam Boiler
1	3" supply
1A	2" supply on rear section *
3	3/4" steam safety valve
4	1/4" siphon, pressure gauge & pressure cut-out
8	3/4" alternate electronic low water cut-off
9	1-1/2" skimmer tapping
10	1/2" low limit for tankless
11A	1/2" tankless inlet
11B	1/2" tankless outlet
12	1/2" steam gauge glass & 67 LWCO
13	1-1/2" bushed to 3/4" for drain cock
14	1-1/2" condensate return

Tapping Loc.	Water Boiler
1	1-1/2" supply
2	3/4" air vent or expansion tank
3	3/4" water relief valve
5A	1/2" tankless inlet
5B	1/2" tankless outlet
6	1/4" pressure temp. gauge
7	1/2" high limit, hi/lo or combination control
13	1-1/2" return & 3/4" drain cock
14	1-1/2" alternate return

Figure 1

* Rear section L-50, L-60, L-70 steam boilers only.

DIMENSIONS

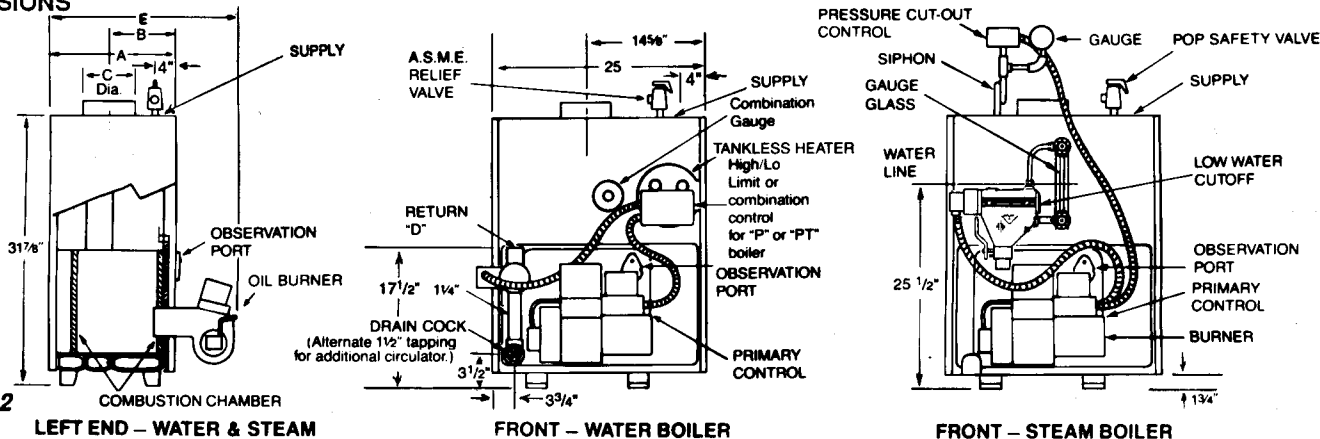

Figure 2

RATINGS

Boiler Model No.*	I=B=R Burner Capacity Oil Input		D.O.E. Heating Capacity MBH		I=B=R Net Ratings			I=B=R Chimney Size		A.F.U.E. %		Dimensions (Inches)					Tankless Heater GPM**		
	GPH †	BTUH	Water	Steam	Water MBH †	Steam MBH †	Steam Sq. Ft.	Nom. Rect. x Height § (in x in x ft)	I.D. Round x Height (in x ft)	Water	Steam	Boiler Length "A"	Front to Flue "B"	Flue Dia. "C"	Return Circulator Flange "D"	Overall Length "E"	Boiler Sect.	Water	Steam
L-20	0.75	105,000	90	—	79	—	—	8 x 8 x 15	5 x 15	83.50	—	11 1/2	8 9/32	5 □	1 1/4	24 1/4	2	2.20	—
L-20BK	0.95	133,000	110	—	96	—	—	8 x 8 x 15	5 x 15	81.76	—	11 1/2	8 9/32	5 □	1 1/4	24 1/4	2	2.40	—
L-30H	1.00	140,000	121	—	105	—	—	8 x 8 x 15	6 x 15	86.00	—	14 7/8	10 1/32	6	1 1/4	27 5/8	3	3.10	—
L-30†	1.10	154,000	134	134	117	101	421	8 x 8 x 15	6 x 15	84.85	84.15	14 7/8	10 1/32	6	1 1/4	27 5/8	3	3.20	3.00
	1.25	175,000	151	—	131	—	—	8 x 8 x 15	6 x 15	83.50	—	14 7/8	10 1/32	6	1 1/4	27 5/8	3	3.40	—
L-40H	1.50	210,000	182	179	158	134	558	8 x 8 x 15	7 x 15	86.00	84.00	18 1/4	11 23/32	7	1 1/4	31	4	3.80	3.40
L-40†	1.60	224,000	195	195	170	146	608	8 x 8 x 15	7 x 15	84.45	83.80	18 1/4	11 23/32	7	1 1/4	31	4	3.90	3.50
	1.80	252,000	218	—	190	—	—	8 x 8 x 15	7 x 15	83.33	—	18 1/4	11 23/32	7	1 1/4	31	4	4.15	—
L-50H	2.00	280,000	243	239	211	179	746	8 x 8 x 15	8 x 15	86.00	84.00	21 5/8	13 13/32	8	1 1/2	34 3/8	5	4.30	3.90
L-50†	2.10	294,000	256	255	223	191	796	8 x 8 x 15	8 x 15	84.06	83.45	21 5/8	13 13/32	8	1 1/2	34 3/8	5	4.40	4.00
	2.35	329,000	272 ‡	—	237	—	—	8 x 12 x 15	8 x 15	—	—	21 5/8	13 13/32	8	1 1/2	34 3/8	5	4.70	—
L-60†	2.60	364,000	298 ‡	298 ‡	259	224	933	8 x 12 x 15	10 x 15	—	—	25	15 3/32	8	1 1/2	37 3/4	6	4.90	4.50
	2.85	399,000	327 ‡	—	284	—	—	8 x 12 x 15	10 x 15	—	—	25	15 3/32	8	1 1/2	37 3/4	6	5.20	—
L-70†	3.10	434,000	352 ‡	354 ‡	306	266	1108	8 x 12 x 15	10 x 15	—	—	28 3/8	16 25/32	9	—	41 1/8	7	5.45	5.00
	3.35	469,000	381 ‡	—	331	—	—	8 x 12 x 15	10 x 15	—	—	28 3/8	16 25/32	9	—	41 1/8	7	5.70	—

Standard working pressure 30 PSI water, 15 PSI steam. All boilers hydrostatically tested — A.S.M.E.

* For forced hot water heating systems where the boiler and all piping are located within the area to be heated, the boiler may be selected on the basis of gross D.O.E. capacity output. The net I=B=R output ratings shown are based on an allowance for piping and pickup of 1.15 (water) or 1.33 (steam). D.O.E. capacity gross output is divided by the allowance to obtain net rating. The manufacturer should be consulted before selecting a boiler for unusual piping and pickup requirements such as intermittent system operation, extensive piping, etc.

† Ratings apply to the use of light oil at 140,000 Btu per gallon, and apply only when burner models listed on pages 11-13 of this manual are used, and are properly adjusted to produce 13% CO₂.

§ Nominal clay tile liner dimensions.

** Tankless heater rating based on intermittent draw.

†† Water boiler models L-30 and larger have two firing rates. The boiler is factory shipped at the lower firing rate. To obtain the higher firing rate, refer to the Liberty boiler installation instructions for the appropriate field adjustments.

‡ I.B.R. gross output

□ Oval

NOTE: All boilers under 300,000 Btu/h input are tested and rated for capacity under the U.S. Department of Energy (D.O.E.) test procedures for boilers.

BOILER LOCATION

Provide a level, solid foundation for the boiler. Location should be near the chimney so that the Flue Pipe Connector or Breeching to the chimney is short and direct.

A. The foundation must be capable of supporting the weight of the boiler when filled with water:

Boiler Size	Approximate Total Weight of Boiler Assembly, filled with water
L-20	440
L-30	550
L-40	660
L-50	785
L-60	895
L-70	1000

B. The Liberty Boiler has full wet base sections which surround fire-box for maximum heat absorption of burning fuel, and low floor temperature.

C. If boiler is to be located over buried conduit containing electric wires or telephone cables, consult local codes or the National Board of Fire Underwriters for specific requirements.

MINIMUM CLEARANCE

Provide accessibility clearance of 24" from surfaces requiring servicing (top and front) and 18" on any side requiring passage. The boiler shall be installed with the following MINIMUM clearances from combustible materials:

A. CHIMNEY CONNECTOR-18"

B. BACK AND SIDES- 6" EXCEPT as limited by 18" clearance from chimney connector

NOTE: Except in closets and alcoves, clearances above in (A) and (B) may be reduced by providing forms of protection as specified in NFPA 31, latest edition.

CHIMNEY REQUIREMENTS

A. The chimney must be constructed in accordance with all local applicable codes and the National Board of Fire Underwriters. See boiler models and rating table shown on page 2 for chimney sizes.

B. Check chimney condition.

Existing chimneys and stacks may have deteriorated; without repairs their use would be hazardous. Before connecting to an old chimney or stack:

1. Clean it.
 2. Inspect it thoroughly.
 3. Remove obstructions.
 4. Replace worn sections of metal stacks.
 5. Seal bad masonry joints.
 6. Repair damaged linings.
- C. Where more than one appliance vents into a common chimney, the area of the common breeching should at least equal the area of the largest appliance flue plus 50% of the additional flue areas.
- D. Breeching area must not be reduced at connection into chimney. Breeching must be inserted into, but not beyond, inside of chimney liner.
- E. Chimney height shall extend at least 3 feet above where it passes through the roof of the building, and at least 2 feet above any ridge within 10 feet of the chimney.
- F. The use of a vent cap, where permitted by code, gives additional protection against adverse wind conditions and precipitation.
- G. Flue Connection: Connect flue pipe between top of boiler and chimney. Horizontal sections of flue pipe must be pitched upward to the chimney at least 1/4" per foot. Flue must be inserted into, but not extend beyond, the inside wall of the chimney flue. Install draft regulator in flue pipe, as shown in figure 3.

AIR SUPPLY AND VENTING

Sufficient air for combustion and ventilation in the boiler room must be provided. Failure to do this will result in poor combustion, heavy sooting and health hazards. Any oil-fired boiler must have a steady draft* and an ample supply of combustion air at all times during firing. If air supply or chimney draft* is unreliable, CO₂ and overfire draft* will change unpredictably.

DO NOT vent this boiler to the same chimney flue used by a fireplace or coal or wood burning furnace or boiler. The draft* produced by solid fueled devices varies tremendously between high fire and low fire:

In modern, weatherstripped, energy-saving buildings, natural infiltration may not supply enough air for combustion, particularly if other fuel-burning appliances, exhaust fans or draft inducers are competing for the same air supply. Fireplaces and other solid fuel burning appliances consume great quantities of air while at high fire; if air supply is not ample, such an appliance will create a down-draft in the oil fired boiler flue: DO NOT operate this boiler and a solid fuel burning appliance at the same time, unless the solid fuel burner is provided with its own outside air supply.

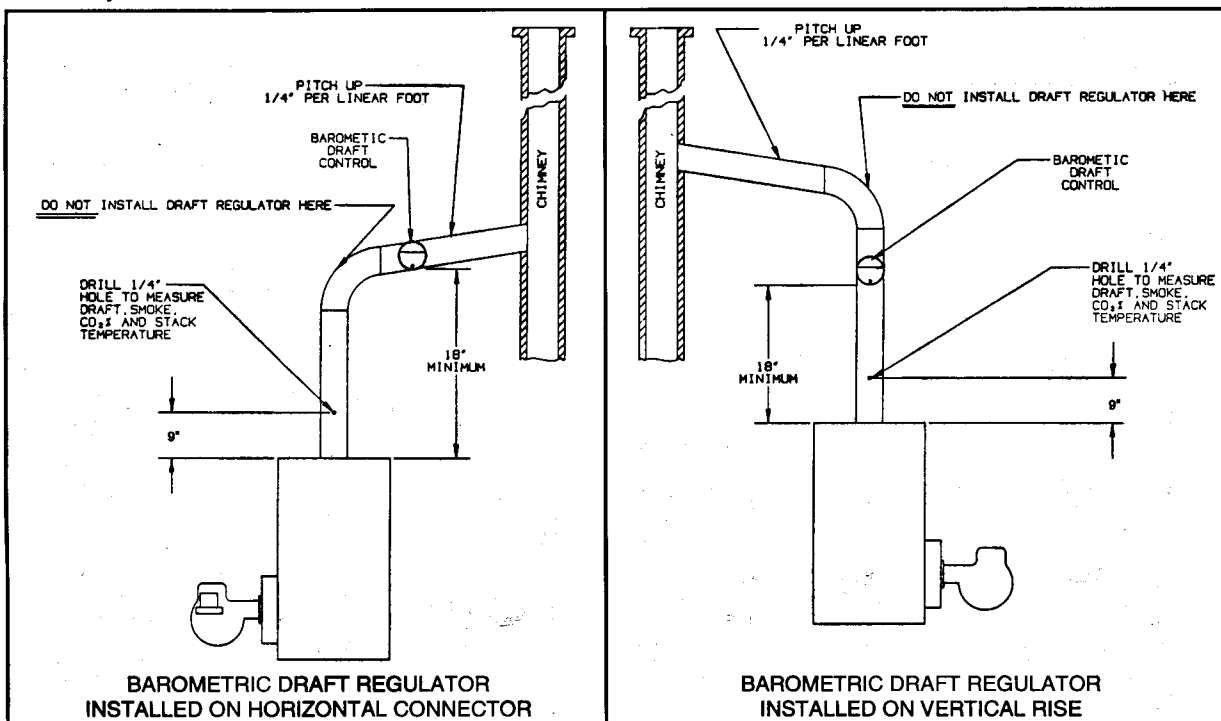

Figure 3. Barometric Draft Regulator

FOR THIS BOILER ONLY, a grilled opening within 12" of the floor near the boiler, direct to or ducted to outside, sized to 140 sq. inch per GPH nozzle size, is recommended for air supply. If such a direct outside air supply is not provided, CO₂ and overfire draft must be checked (refer to STARTUP) after closing all doors and windows that will be closed on the coldest day, and operating all fuel burning appliances including this boiler for at least 30 minutes of continuous operation.

If fly screen must be used over air supply openings, areas calculated should be doubled; the screen should be inspected and cleaned frequently to maintain free air flow.

Protect air openings against closure by snow, debris, etc. Openings such as doors or windows, if used, must be locked open.

The opening size recommendation just given is for guidance only. It is an installation responsibility to provide air for combustion and ventilation to all appliances, under all operating conditions, for each installation.

*Draft is negative or suction pressure.

INSTALLING CONTROLS AND ACCESSORIES ON BOILER UNITS

Notes: Jacket must be installed on boiler units prior to installation of trim.

- I. STEAM BOILER TRIM, see page 2 for tapping locations, and figure 4 for illustration of steam boiler.
 - A. Steam pressure gauge and pressure cut-out, install in tapping no. 4, figure 4.
 - B. Gauge glass set — use tapping no. 12.
 - C. Pop safety valve — use tapping no. 3, piped full size to boiler; or pipe full size into a valveless steam header.

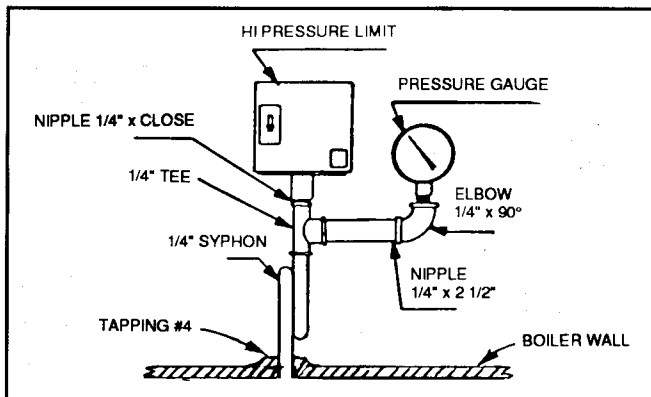

Figure 4.

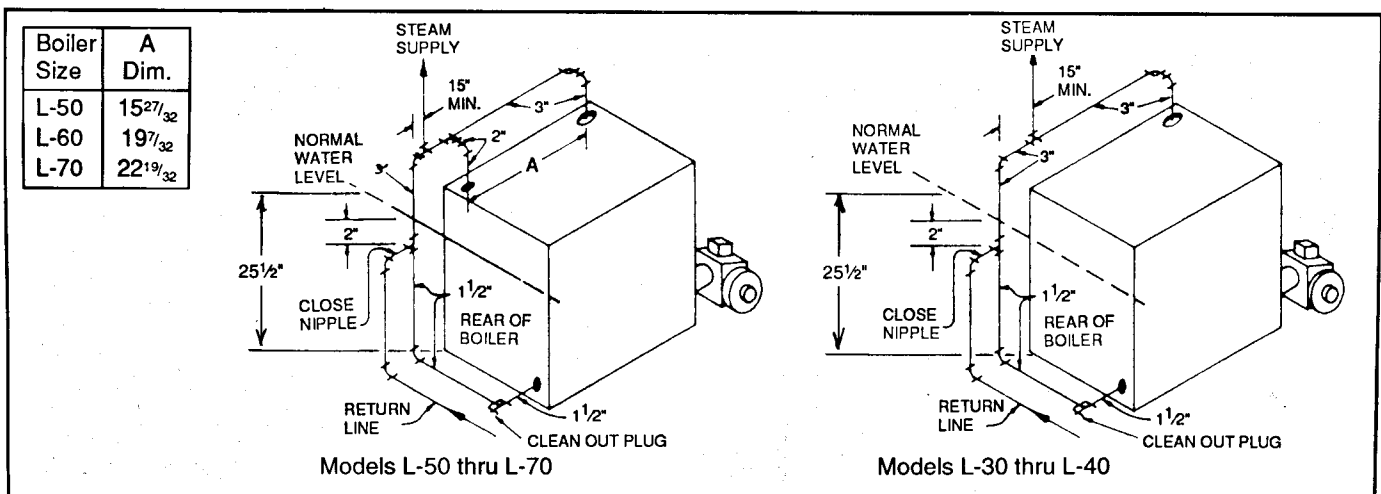

Figure 5. Recommended Steam Piping at Boiler

- D. Combustion safety control — mounted on burner.
- II. WATER BOILER TRIM, see page 2 for tapping locations, and figures 1 and 2 for illustration of water boiler.
 - A. Pressure-temperature - Altitude gauge — use tapping no. 6.
 - B. High temperature limit — use tapping no. 7.
 - C. Operating control (if used) — use tapping no. 7.
 - D. Water relief valve — use tapping no. 3, piped full size to boiler.
 - E. Automatic air vent or compression tank tappings — if used, install in tapping no. 2.
 - F. Combustion safety control — mounted on burner.

PIPING FOR STEAM BOILERS

Provide Header and Hartford Loop as suggested. See figures 4 and 5. Local codes apply.

CLEANING PIPING SYSTEM

- A. To clean piping system, open all valves at the heating elements. After getting up a good head of steam, shut the boiler down and allow the condensate to return to the boiler. The condensate will carry the oil film with it. Again blow-off the boiler. On extremely fouled systems, it may require several visits over a few days to clean the system.
- B. When steam only (no water) is released through the hand valve, the boiler will not surge or flood.

PIPING FOR WATER UNITS

NOTE: On knock down boiler only, jacket may be installed after supply and return piping connection, but must be installed prior to adding trim.

I. CIRCULATING SYSTEM

- A. FORCED CIRCULATION hot water heating system: Use the top tapping as supply tapping, and use the front or rear bottom tappings for the return.
- B. A FLOW CONTROL VALVE (See figure 6) will prevent gravity circulation and usually is required when tankless heater is installed.

II. AIR CONTROL SYSTEMS

- A. DIAPHRAGM-TYPE COMPRESSION TANKS are used to control system pressure in an AIR ELIMINATING SYSTEM: an automatic air vent is used to REMOVE air from the system water. See figure 6. If system pressure needs further control, add an additional tank or install a larger capacity tank. The automatic air vent should be installed in the top of the boiler, as in figure 6.
- B. CONVENTIONAL COMPRESSION TANKS (non-diaphragm type) are used to control system pressure in an AIR COLLECTING SYSTEM. Within the system, after initial start-up and venting, air is collected in the tank and acts in contact with the water to control pressure. Air is not vented from this system. If system pressure needs further control, add another tank in

parallel with the original tank or install a large capacity tank. Locate the tank at the inlet end of the pump near the boiler. (See figure 7)

- C. **HOT WATER RADIATION VENTING** - Manual air vents should be installed at the top of all "drops" (where piping goes downward). Air must be vented or purged from all zone lines to permit proper system heating.
- D. **PUMP LOCATION** - Locating low-head pump(s) on return to boiler is acceptable for smaller boiler sizes in residences of one or two stories. (See figure 6) The pump location shown in figure 7 is required in large, multi-story building installations, especially when high-head pumps are used.
- E. A conventional compression tank may be connected to the 3/4" tapping as shown in figure 7.

IMPORTANT: Hot water heating systems containing high water volume, such as would occur with cast iron radiation, require special care with air elimination.

The circulator pump should be located on the boiler supply pipe and the expansion tank and air scoop should be located near the pump suction. (See Figure 6, Alternate Pump Location.)

PIPING TANKLESS HEATER (if used)

- I. Heater capacities are listed on Page 2.
- II. Pipe the built-in tankless heater using the inlet and outlet tapings indicated on the heater (figure 8).
 - A. Tempering valve (illustrated, but not furnished) is suggested to provide more volume of temperate water to kitchen and bath.
 - B. High temperature water, for dishwasher and laundry, may be piped direct.
 - C. A flow control valve should be used to control the rate of flow of water through the coil, otherwise the heating capacity of the coil will be exceeded. To insure sufficient hot water, the flow rate through the coil should be limited to a maximum shown for intermittent draw in the ratings table on page 2.

INSTALLING THE BURNER

See Burner Data, pages 11-15, and Burner Manual supplied with burner. If burner is not mounted as received, mount to boiler, placing flange over mounting studs. Use gasket between flange and boiler. Distance between flange and nose of burner must be as shown on pages 11-15. Check to see that nozzle and settings are as given in burner data tables, pages 11-15.

OIL SUPPLY PIPING

Install the oil tank or tanks and piping from tank to burner. Follow local codes and practices, NFPA No. 31, INSTALLATION OF OIL BURNING EQUIPMENT and the instruction sheet attached to the oil burner pump. A one-pipe system should be used for gravity fed fuel systems and for lift systems, where the total lift is less than 8 feet. Where the total lift is greater than 8 feet, a two-pipe system must be used. In some instances, local codes may require a two-pipe system for below grade fuel oil tanks. Be sure to set-up the fuel oil pump for the piping system used; follow the instructions attached to the pump. Be sure to include a good quality, low pressure drop fuel oil filter in the supply line from the tank. This is necessary, especially at low fuel oil flow rates (small nozzle sizes), to prevent nozzle plugging. See Slant/Fin publication on one-pipe and two-pipe fuel oil systems.

WIRING THE BOILER

- A. The wiring diagrams for the burner and boiler may be found on pages 9 & 10.
- B. 24 volt control wiring should be approved Safety Circuit wire, protected as needed.
- C. Power supply wiring to the burner must be 14 gauge or heavier, as required, and should have a properly fused disconnect switch. 120 volt wiring to pumps and safety controls must also be 14 gauge or heavier. Wire must be enclosed in approved conduit.
- D. All wiring must be installed in compliance with the National Electric Code, or any local or insurance codes having jurisdiction.

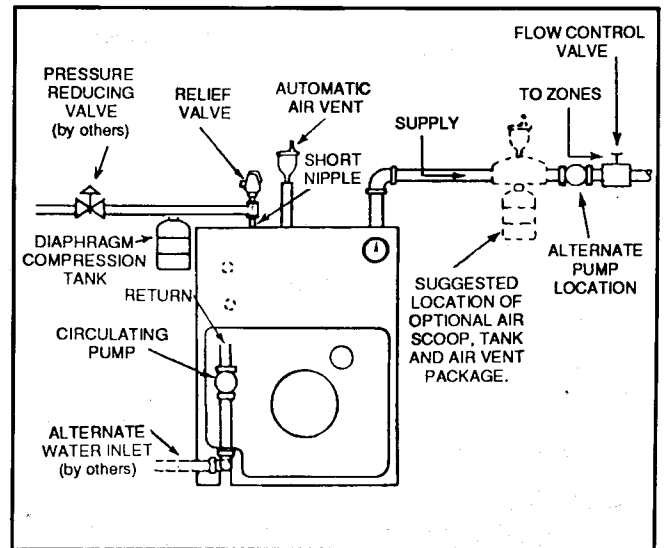

Figure 6. Air Eliminating System

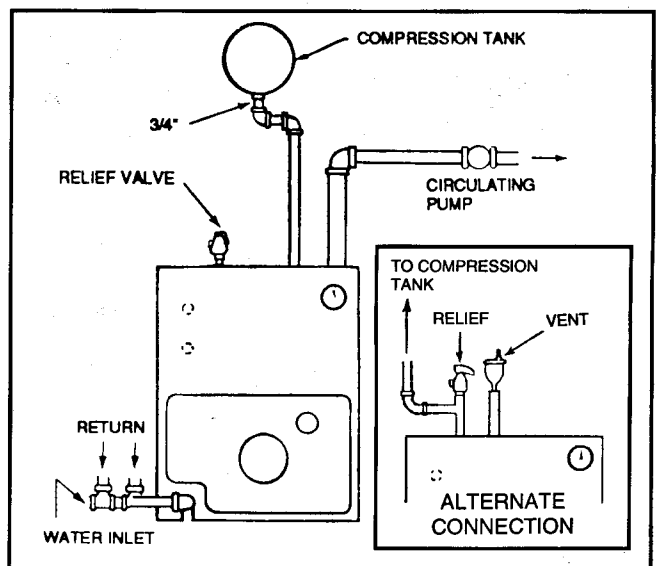

Figure 7. Air Collecting System

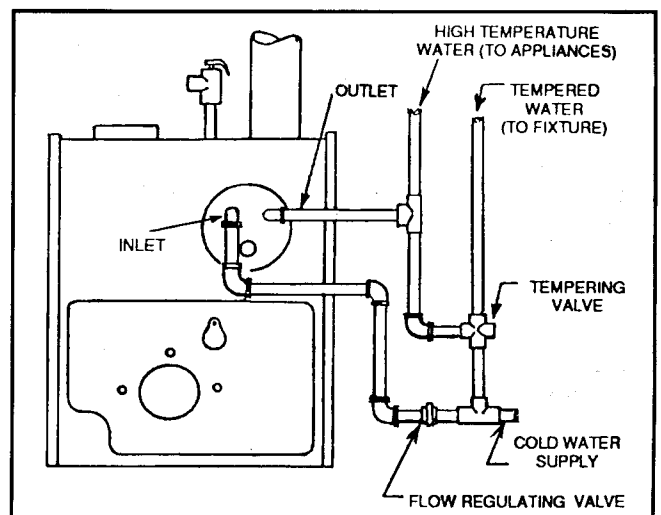

Figure 8. Recommended Piping to Tankless Heater

VENT PIPING AND DRAFT REGULATOR

- A. Vent pipes must be installed having the same diameter as the boiler outlet. (See page 2.)
- B. Vent pipes and breeching must be pitched upward a minimum of 1/4" per foot.
- C. Connect vent pipe to the chimney using as few elbows as possible.
- D. Horizontal vent connector into the chimney should not be inserted beyond the inside wall of the chimney.
- E. Install barometric draft regulator on horizontal breeching, near chimney, with hinge horizontal and face vertical. See manufacturer's instructions packed in carton with barometric draft regulator.
- F. If two or more appliances are used on the same chimney, see CHIMNEY, page 3.
- G. Make up all joints with minimum air leaks, secure with sheet metal screws.

PRECAUTIONS BEFORE STARTING OIL BURNER

Make a positive check of A through F before starting burner:

- A. Boiler and system are full of water. All air is vented from system. See below.
- B. All wiring is completed. See pages 9 & 10.
- C. Oil supply is connected to the burner; nozzle is installed correctly; oil valve is open at tank.
- D. Smokepipe is connected to chimney.
- E. All combustible materials are cleared away.
- F. Combustion air supply is provided. See page 3.
- G. Burner settings are adjusted as per pages 11-15 and as shown on boiler jacket.

WARNING: NEVER OPERATE any natural draft* boiler (Liberty boiler is a natural draft boiler) with zero draft or overfire pressure: early failure of the burner, nozzle and chamber is inevitable if you do. Use a draft gauge, and make sure that overfire draft* is .02", minimum, during all operating conditions.

* Draft is negative or suction pressure.

STARTUP (COMBUSTION TEST INSTRUMENTS MUST BE USED)

- A. Make sure the boiler is installed and wired properly and is full of water.
- B. Open the observation door (on the front, above the burner).
- C. Start the oil burner (see burner instructions for bleeding air from oil, etc.). IMMEDIATELY, set burner air bands to obtain a bright fire without smoke or oil stain. Set the DRAFT REGULATOR to obtain .02" overfire draft*. Take draft reading through slot in observation door.
- D. Close the observation door. Allow the burner to fire for at least one hour total firing time, to bake out the volatile binders in the combustion chamber before taking final combustion readings.
- E. By alternate adjustment of the barometric draft regulator, the burner air regulation and head regulation devices (whichever apply), set for a trace of smoke and as close to 13% CO₂ as you can. Then open the air bands or shutter (whichever apply) an additional 1/8". This should result in zero smoke with NO raw oil on the smoke paper and a smooth light-off. DO NOT ATTEMPT TO SET FIRE BY EYE. Flame retention burners may appear efficient and smoke free from an inefficient 7% up to an overly high 14% CO₂. However, a very low CO₂ can also result in poor ignition and raw (unburned) oil entering the fire box. At very high CO₂, any slight decrease in air flow for any reason will cause incomplete combustion, with high smoke and dry soot formation in the fire box.
- F. If smoke reading is satisfactory, but CO₂ can not be increased to a satisfactory level (12% or better) or overfire draft of 0.02" W.C. can not be obtained, check for proper sealing between sections, between burner mounting plate and front section, around burner blast tube and around flue collector and collar. If seal is not satisfactory, reseal with furnace putty or silicone with a temperature rating of at least 400° F. (All safety precautions indicated on material package must be followed.)
- G. Once burner and draft have been set-up, then smoke, CO₂ and

stack temperature should be checked and recorded. If smoke is greater than trace, review the burner instructions; replace the nozzle if necessary. Normal smoke to be expected at approximately 13% CO₂ is zero to a trace.

CLEANING AND FILLING A NEW WATER BOILER

I. BEFORE FILLING WATER BOILER.

- A. Check burner to be certain it is ready for firing. DO NOT FIRE into an empty boiler.
- B. Be prepared to heat raw water to at least 180°F. as soon as it is introduced into the boiler. This procedure will remove dissolved, corrosive gases.
- C. Provide drain line, with valve, from boiler. Use a bottom tapping. Line and drain must be suitable for handling caustic solution.

II. CLEANING WATER BOILER SYSTEM

- A. Prepare a boil-out solution of *sodium hydroxide* (caustic soda) or *tri-sodium phosphate*.

NOTE: Use caution in handling chemicals. Caustic soda is harmful to skin, eyes and clothing.

1. Proportions: 1 lb. of either chemical per 50 gallons of system water.
2. Stir chemical in water until dissolved and pour into the boiler through a top tapping. Replace plug.
- B. Fill the entire system with water.
- C. Start the burner, using the start-up procedure.
- D. Circulate the water through the entire system.
- E. Vent the system, including the radiation.
- F. Allow boiler water to reach operating temperature, if possible.
- G. Continue to circulate the water for a few hours.
- H. Shut off the burner.
- I. With CAUTION, drain the boiler solution to a safe location. DO NOT LEAVE SOLUTION SITTING IN SYSTEM OVER 2 HOURS.
- J. Wash the water-side of the boiler thoroughly using a high pressure water stream. Fill and drain the boiler several times.

III. TREATING WATER FOR CORROSION CONTROL

(This is not Scale Control)

- A. Prepare a solution of *sodium chromate*. Proportions: 6 oz. per 50 gallons of system water.
- B. Stir chemical into water until dissolved and pour into the boiler through a top tapping. Replace plug.

IV. FILLING AND VENTING THE WATER BOILER.

- A. Refill the system with fresh water.
- B. Bring water temperature to at least 180° F promptly.

WATER CONTENT OF BOILER (GALLONS)

	L-20	L-30	L-40	L-50	L-60	L-70
Water Boiler	8.3	10.7	13.1	15.5	17.8	22.6
Steam Boiler	—	6.9	8.8	10.7	12.6	14.5

VOLUME OF WATER IN STANDARD PIPE OR TUBE

Nominal Pipe Size Inches	Standard Steel Pipe			Type L Copper Tube	
	Schedule No.	Inside Diameter Inches	Gallons per Lin. Ft.	Inside Dia. Inches	Gallons per Lin. ft..
3/8	—	—	—	0.430	0.0075
1/2	40	0.622	0.0157	0.545	0.0121
5/8	—	—	—	0.666	0.0181
3/4	40	0.824	0.0277	0.785	0.0251
1	40	1.049	0.0449	1.025	0.0429
1 1/4	40	1.380	0.0779	1.265	0.0653
1 1/2	40	1.610	0.106	1.505	0.0924
2	40	2.067	0.174	1.985	0.161
2 1/2	40	2.469	0.249	2.465	0.248
3	40	3.068	0.384	2.945	0.354

- C. Circulate water through entire system.
- D. Vent the system, including the radiation.
- E. The boiler is now ready to be put into service or on standby.
- F. If brand-name air-control devices are used, venting instructions furnished with the devices should be followed.

V. SAFETY CHECK FOR CONTROL SYSTEM

High limit control test: Set thermostat high enough for boiler water temperature to reach high limit control setting. When this temperature is reached, the high limit switch should open, and the burner should shut off automatically. If the high limit does not operate to shut off the burner, the high limit or the wiring is faulty. Repair or replace immediately.

CLEANING AND FILLING A NEW STEAM BOILER

I. BEFORE USING STEAM BOILER.

- A. Check burner to be certain it is ready for firing. **DO NOT FIRE** into an empty boiler.
- B. Be prepared to heat raw water to at least 180°F as soon as it is introduced into the boiler. This procedure will remove dissolved, corrosive gases.
- C. Provide drain line, with valve, from boiler. Use a bottom tapping. Line and drain must be suitable for handling caustic solution.
- D. Check for low water cut-off operation, see section below for check out.

II. CLEAN STEAM BOILER SYSTEM.

- A. Fill the boiler to water line indicated on the boiler.
- B. Follow start-up procedure for burner and operate the boiler with steam in the entire system for 2 or 3 days to bring oil and dirt from the system to the boiler. While system is in operation, maintain the proper water level in the boiler by slowly adding water to the boiler.
- C. Shut down burner, cool down boiler and drain system.
- D. Procedure to dissolve oil and grease in boiler:
 1. Fill boiler to proper water line.
 2. Prepare a boil-out solution of *sodium hydroxide* (caustic soda) and *tri-sodium phosphate*.
NOTE: Use caution in handling chemicals. Caustic soda is harmful to skin, eyes and clothing.
(a) Proportions: 1 lb. of each chemical per 50 gallons of system water.
(b) Stir chemicals into water until dissolved and pour into the boiler through a top tapping. Replace plug.
 3. Start the burner; boil the water for at least 5 hours; shut off the burner.
- E. With CAUTION, drain the boiler solution to a safe location. **DO NOT LEAVE SOLUTION SITTING IN SYSTEM OVER 2 HOURS.**
- F. Wash the water side of the boiler thoroughly using a high pressure water stream. Fill and drain the boiler several times.

III. TREATING WATER FOR CORROSION CONTROL

(This is not scale control).

- A. Prepare a solution of *sodium chromate*.
Proportions: 1 lb. per 50 gallons of boiler water.
- B. Stir chemical in water until dissolved and pour into boiler through a top tapping. Replace plug.

IV. FILLING AND VENTING THE STEAM BOILER.

- A. Refill the boiler to the indicated water line.
- B. Bring water to boiling temperature, promptly.
- C. The boiler is now ready to be put into service or on standby.

BLOWING OFF A LOW PRESSURE STEAM BOILER

- A. A 1-1/2" NPT tapping is provided in the front of the boiler (tapping no. 9, figure 1) for use as a surface blow down to provide rapid skimming of oil and grease which accumulate on the surface of the water. The boiler should be blown down as outlined below.
- B. Turn off electrical power supply to boiler. Allow boiler to cool down and steam pressure to reduce to zero before removing skimmer tapping plug. Check for steam pressure by testing the pop safety valve. Keep your hands and all parts of your body away from the discharge end of the safety valve. Drain boiler

down one to two inches below skimmer tapping. The water might be hot. Remove skimmer plug slowly and carefully install a 150 psi malleable iron 1-1/2" NPT street elbow, a 1-1/2" NPT skimmer valve and length of pipe and place a bucket underneath the open end of the pipe. Cover bucket with a piece of cloth. (See figure 9.)

- C. Fill boiler slowly until water level is two inches from top of gauge glass. (This is the starting water level for skimming only). Fire boiler to produce steam. If the system is heavily laden with oil, it may be difficult to obtain much more than a pound or so of pressure. Set the pressure control at about 7 psi. The higher the steam pressure you can use, the better and faster the cleaning.
- D. As steam develops, open the SKIMMER drain valve with caution to skim the oil and film from the top of the water. **DO NOT** open the boiler drain valve. Close the skimmer drain valve when the water level drops to about 5" from the top of the gauge glass. The water may stop before the level drops to 5" below the top of the glass. Refill boiler until water level is again two inches from the top of the gauge glass.
- E. Repeat (D) above until all film is skimmed off and the water settles to a normal movement. Add make up fresh water to the boiler as described in (D) above, during the blow-off operation, to maintain the proper skimming water level in the vessel. Empty bucket frequently in order to see the difference in water cleanliness.
- F. When surging has stopped and water is clean, and no film can be seen floating in the bucket, shut off boiler, drain down to level of skimmer tapping, remove valve, plug skimmer tapping and refill the boiler to 24-1/2" water level.
After 15 minute operation, readjust level to normal operating level of 25-1/2" from bottom of boiler (see figure 9). Check the pop safety valve for proper operation.
Check for low water cut-off operation, see next page.
- G. The entire process may have to be repeated over a period of a few days on extremely fouled systems.

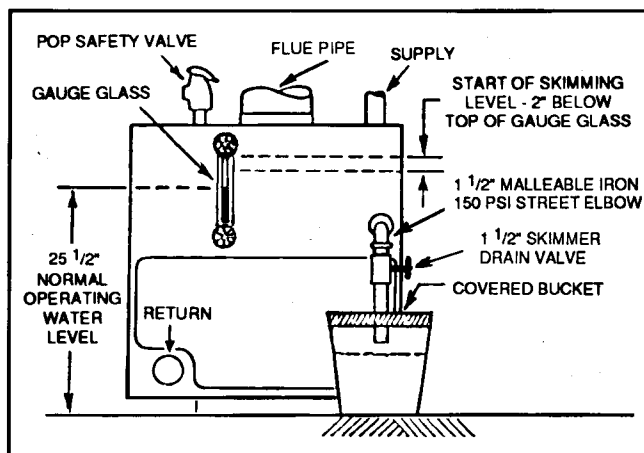

Figure 9.

LOW WATER CUT-OFF CHECK-OUT

- I. Electronic probe type low water cut-off. If this boiler is factory equipped with an electronic probe type low water cut-off, operation of cut-off should be checked at least twice a year as follows:
 - A. While boiler is running, drain down boiler water slowly through Boiler Drain Cock shown on page 4, just until light goes on. Boiler should shut down 10 seconds after light goes on.
 - B. Be sure that it is the low water cut-off and not the room thermostat, pressure cut-out, or other control that has shut-off the burner.
 - C. Refill the boiler and repeat test.
 - D. Refill the boiler and reset controls for normal operation.
- II. Float type low water cut-off
If this boiler is factory equipped with a McDonnell & Miller float type low water cut-off, the low water cut-off must be blown down (flushed), at least once a week.

CAUTION: When flushing float type low water cut-off control, hot water and steam will flow out the blow down valve. Blow down valve is illustrated below.

A. SPECIAL FLUSHING INSTRUCTIONS

For new boiler installed in old system.

Installation of new boiler may break loose a heavy accumulation of sediment and scale from old piping and radiators. It is extremely important to blow down your McDonnell cut-off more frequently the first week.

First week — 3 times

Thereafter — at least once a week.

- B. As boiler water circulates through the float chamber, dirt or other sediment may be deposited. This chamber is extra deep. But the only sure way to keep any accumulation from interfering with float action is to "blow down", or flush out, the control once a week.

Do it while boiler is in operation. First note water level in gauge glass. Open blow-off valve at bottom of control; water will pour out, flushing away sediment. Drain until water is clear — about a pail — then close valve. If level in gauge glass has dropped, add water to boiler to restore level.

- C. NOTE: Opening blow-off valve checks cut-off operation too. As float drops with falling water level, burner will stop. After burner is off and normal operating conditions restored, burner will resume firing.
- D. Be sure that it is the low water cut-off and not the room thermostat, pressure cut-out, or other control that has shut off the burner.

PRESSURE CONTROL CHECK-OUT

- A. Check burner to be certain it is ready for firing. DO NOT FIRE into an empty boiler.
- B. Set thermostat high enough for boiler to make steam. Set the pressure control down to its lowest setting. As the boiler starts to produce steam, the steam pressure will start to build. The burner will shut-off when the steam pressure exceeds the pressure setting (plus differential if control has this feature).
- C. Adjust the pressure control to a higher setting. The higher setting should be above the steam pressure in the boiler. This should turn the burner back on.
- D. Reset the pressure control as needed for the system. The pressure control should be checked at least twice a year.

REPLACEMENT OF STEAM BOILERS

Anytime an older steam boiler is removed from the heating system and replaced with a new boiler, there are certain conditions that have to be examined on the heating system.

- A. Steam systems have a tendency to develop scale inside the wet return lines and the boiler. The older the system the greater the accumulation of scale that can exist inside the piping. Therefore, it is necessary when replacing a steam boiler to check the piping for blockage or restrictions. Clean or replace the piping as required. (See special flushing instructions above.)
- B. Replace all buried wet return lines.
- C. All equipment (air vents, radiation equipment, etc.) in the steam heating system should be checked for proper operation. All piping should be checked for proper pitch.
- D. It is good engineering practice to repack or tighten the packing nuts on all valves in the heating system.

STEAM CONTROL ASSEMBLY

Installed McDonnell & Miller 67 low water cut-off and water level gauge.

SPECIAL FLUSHING INSTRUCTIONS

Installation of new boiler may break loose a heavy accumulation of sediment and scale from old piping and radiators. It is extremely important to blow down your McDonnell Cut-off more frequently the first week.

First week—3 times

Thereafter—at least once a week.

See "CARE & MAINTENANCE" section for instructions.

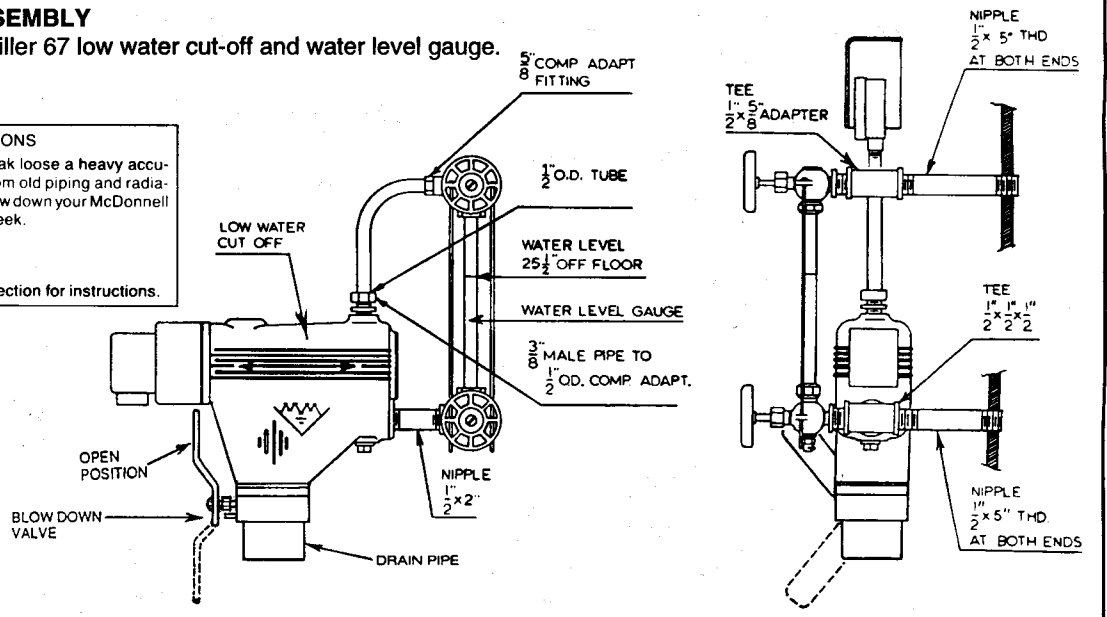

BASIC WIRING DIAGRAMS

L8124C or A
(with tankless heater)
L8148A
(without tankless heater)

NOTES:

1. Recommended high limit setting is 200°F. Low limit must be set at least 20°F below high limit setting.
2. Pump zoning terminals ZR, ZC furnished on L8124 controls only. See pump zoning diagram below.

† Overload protection and disconnect switch must be provided as required by local codes.

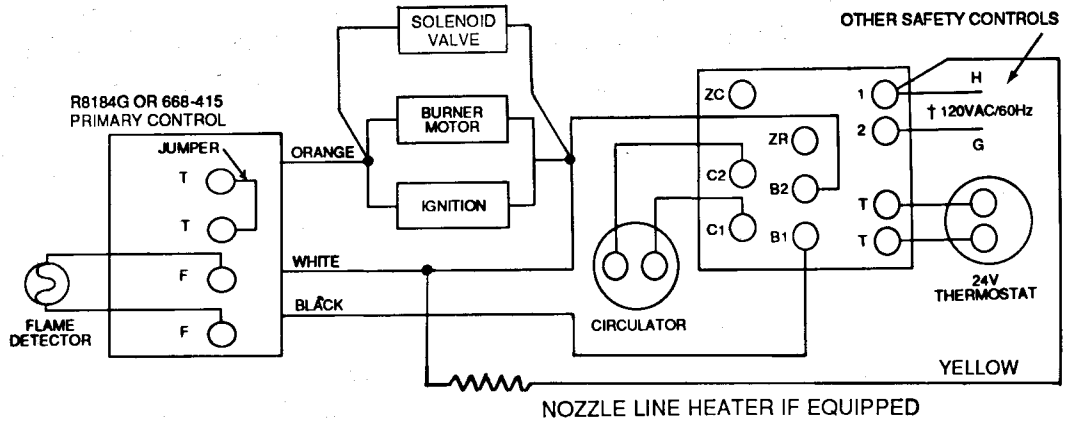

ZONE WIRING DIAGRAM, CIRCULATOR METHOD (L8124)

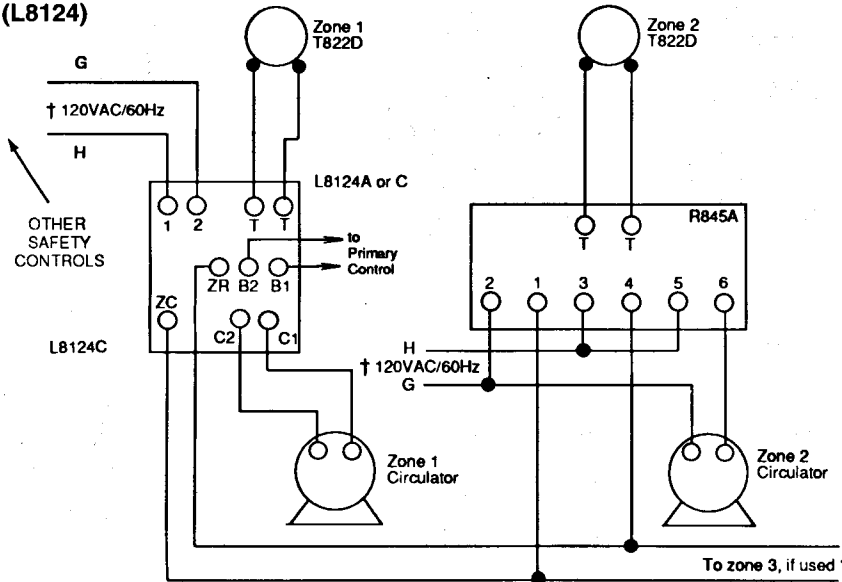

* Note: Total circulator load not to exceed 8 amp full load, for circuits shown.

MULTIPLE ZONE WIRING DIAGRAM, ZONE VALVE METHOD

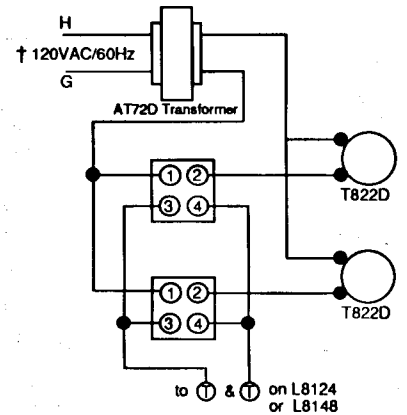

NOTES:

1. Recommended high limit setting is 200°F. Low limit must be set at least 20°F below high limit setting.
2. Pump zoning terminals ZR, ZC furnished on L8124 controls only. See pump zoning diagram below.

† Overload protection and disconnect switch must be provided as required by local codes.

WIRING FOR L8148A PUMP ZONE DIAGRAM

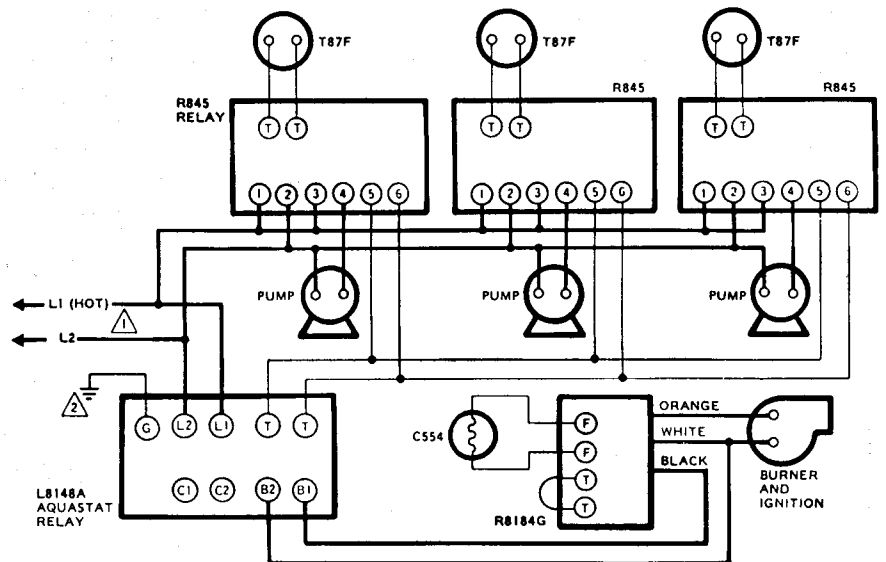

1. POWER SUPPLY. PROVIDE DISCONNECT MEANS AND OVERLOAD PROTECTION AS REQUIRED.
2. CONTROL CASE MUST BE CONNECTED TO EARTH GROUND. USE GROUNDING SCREW PROVIDED.

WIRING FOR PACKAGED STEAM BOILER EQUIPPED WITH MC DONNELL NO. 67 L.W.C.O.

High-Pressure Limit
 •recommended setting 0.5 PSI
 •differential 5 PSI

Low Limit (tankless model only)
 •recommended setting 160°F

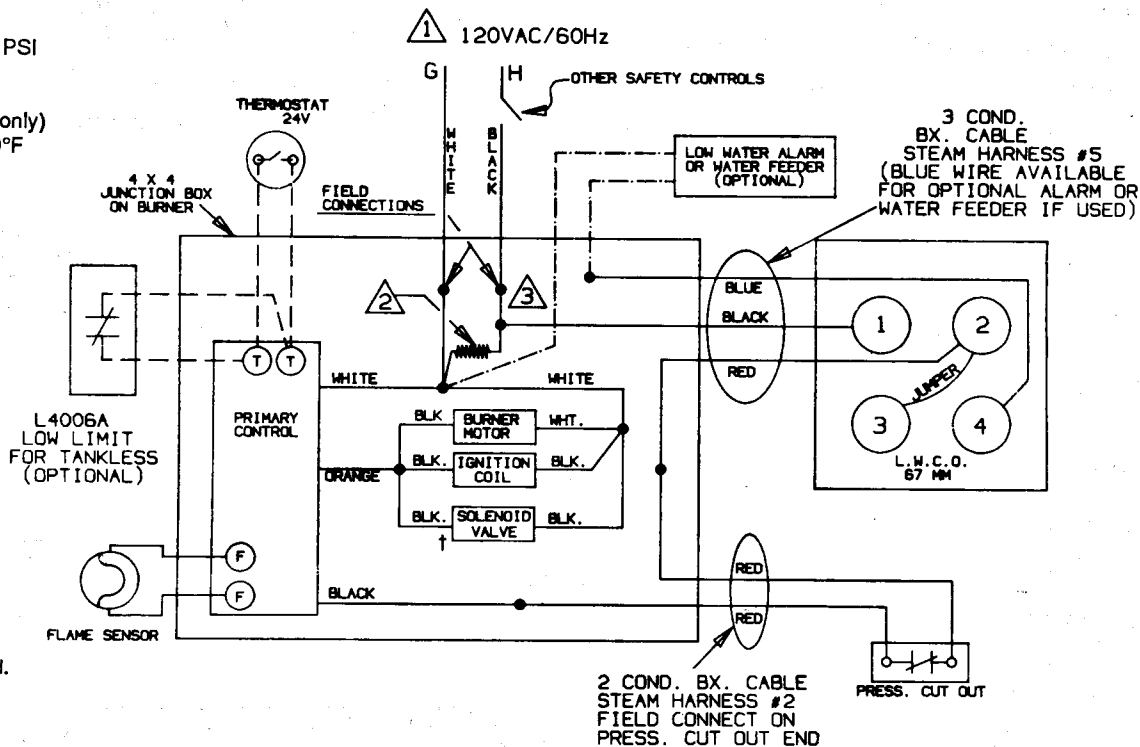

† Solenoid valve if equipped.

• Splice

○ Terminal

① Overload protection and disconnect switch must be provided as required by local codes.

② Nozzle line heater, if equipped.

③ On burners without nozzle line heater, field connect hot line to single black wire from 3 conductor box cable in 4 x 4 junction box.

WIRING FOR PACKAGED STEAM BOILER

For alternate option PS-801-120 L.W.C.O.

High-Pressure Limit
 Recommended setting — 0.5 PSI
 Differential — 5 PSI

Low limit (Tankless Model only)
 Recommended setting — 160° F

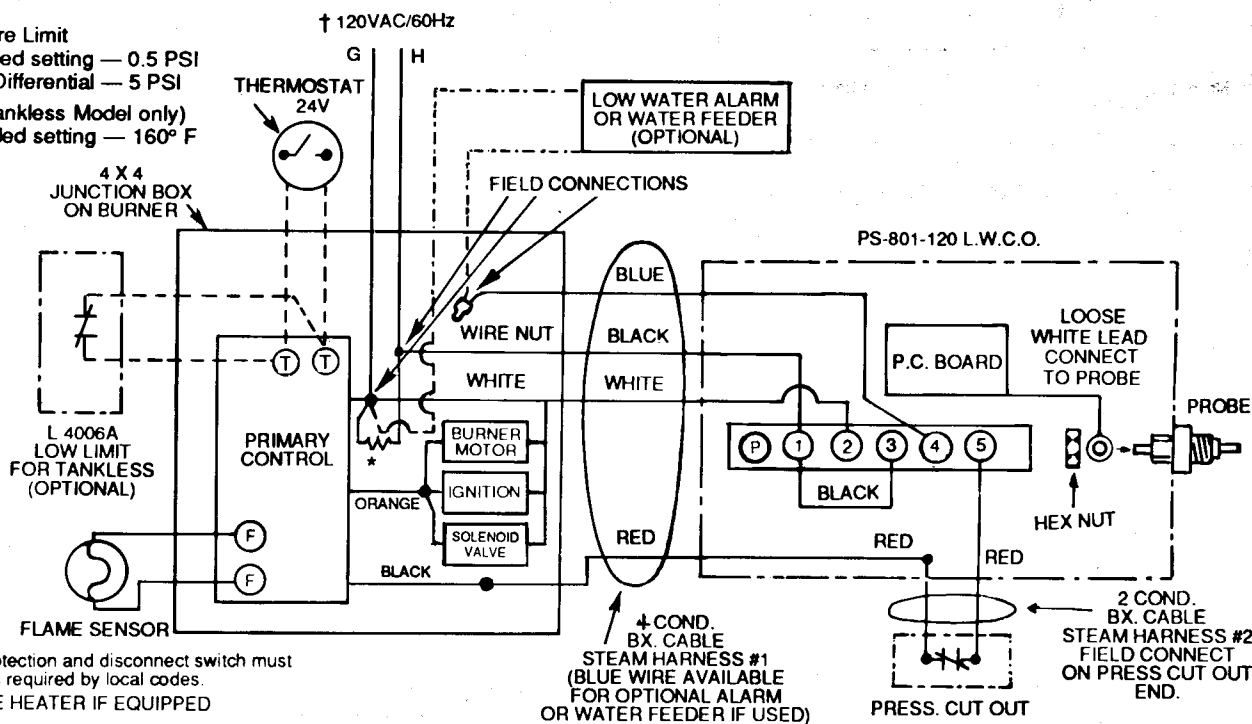

† Overload protection and disconnect switch must be provided as required by local codes.

*NOZZLE LINE HEATER IF EQUIPPED

BURNER DATA — CARLIN BURNERS FOR PACKAGED BOILERS ONLY

(For knocked down & boiler burner units see publication no. L-42KB)

BOILER MODEL	BURNER MODEL *	FIRING RATE NO.2 OIL (GPH)	NOZZLES			OIL PUMP PRESSURE SETTING (PSIG)	"A" APPROX. HEAD SETTING NO.†	APPROX. AIR BAND OPENING % †
			SIZE (GPH)	ANGLE & TYPE	MFR.			
L-20	71357 99-FRD	.75	.75	70° A	DELAVAN	100	1.0—2.0	45—50
L-30H	71357 99-FRD	1.00	1.00	60° A	DELAVAN	100	2.0—3.0	70—80
L-30	71357 99-FRD	1.10	1.10	60° A	DELAVAN	100	2.0—3.0	80—90
	71357 99-FRD	1.25	1.25	60° A	DELAVAN	100	2.0—3.0	90
L-40H	71373 99-FRD	1.50	1.50	45° ES	HAGO	100	3.0	50
	70° B			DELAVAN				
L-40	71373 99-FRD	1.60	1.50	70° SS	HAGO	113	4.0	60
	70° W			DELAVAN				
	71373 99-FRD			1.80	1.75			
L-50H	71399 99-FRD	2.00	2.00	45° P	HAGO	100	3.0	40
	60° B			DELAVAN				
L-50	71399 99-FRD	2.10	2.00	70° W	DELAVAN	110	3.0	50
	70° SS			HAGO				
	71399 99-FRD			2.35	2.25			
L-60	71316 102-CRD-3	2.60	2.50	70° P	HAGO	108	5.0	50
	70° W			DELAVAN				
	71316 102-CRD-3	2.85	2.75	70° P	HAGO	107	6.0	80
	60° W			DELAVAN				
L-60 BAR N.Y.C. ONLY	87189 102-CRD-3	2.60	2.50	45° SS	HAGO	107	5.0	50
L-70	71332 102-CRD	3.10	2.75	60° SS	HAGO	125	8.0	90
	60° W			DELAVAN				
	71332 102-CRD	3.35	3.00	60° SS	HAGO	125	10.0	90
	60° W			DELAVAN				
L-70 BAR N.Y.C. ONLY	78790 102-CRD	3.10	3.00	60° B	DELAVAN	107	8.0	90
	60° SS			HAGO				

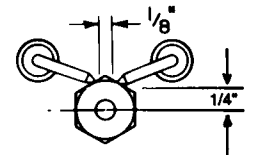
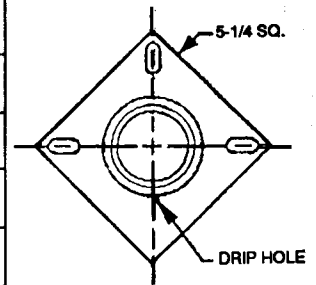
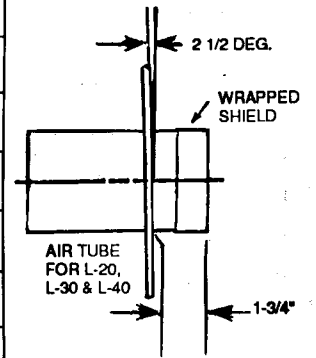

† Head and air band settings are approximate ONLY. See STARTUP on page 6 and burner figure below.
* All burner models shown are single stage.

NOTE:

1. The air shutters on the burners for models L-20, L-30 and L-40 are blank (closed).
2. The air shutters on the burners for models L-50, L-60 and L-70 are full open.
3. Single slotted air band for L-20 and L-30.
4. Double slotted air band L-40, L-50, L-60 and L-70.

See table for approximate settings.

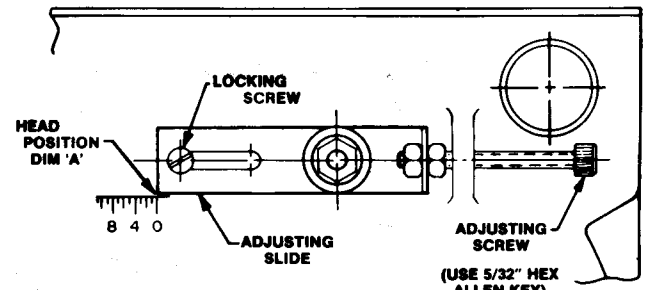
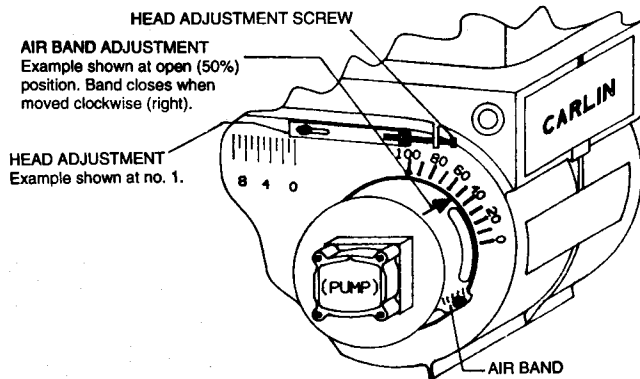
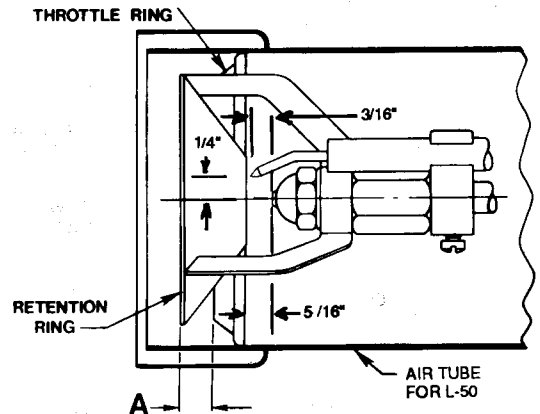
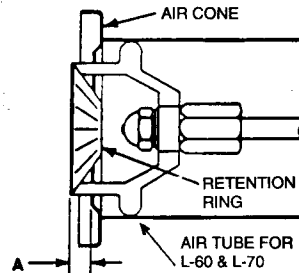

BURNER DATA — BECKETT BURNERS FOR PACKAGED BOILERS ONLY

(For knocked down & boiler burner units see publication no. L-42KB)

BOILER MODEL	BURNER MODEL *	BURNER HEAD	FIRING RATE (GPH)	NOZZLES		OIL PUMP PRESSURE SETTING (PSIG)	APPROX. AIR SHUT-TER SETTING NO. †	APPROX. AIR BAND SETTING NO. †	
				SIZE (GPH)	ANGLE & TYPE				MFR.
L-30	AFG-SF-11-07	F4S	1.00	1.00	80° SS	HAGO	100	8	CLOSED
					80° A	DELANVAN			
					80° W	DELANVAN			
			1.10	1.10	80° ES	HAGO	100	9	CLOSED
					80° W	DELANVAN			
					80° ES	HAGO			
L-40	AFG-SF-11-02	F120	1.60	1.50	80° ES	HAGO	113	10	1-1/4
					80° B	DELANVAN			
					80° W	DELANVAN			
			1.80	1.75	80° SS	HAGO	105	10	3
					80° B	DELANVAN			
					80° W	DELANVAN			
L-50	AFG-SF-11-05	F164	2.10	2.00	80° P	HAGO	110	10	1-1/2
					80° W	DELANVAN			
					80° W	DELANVAN			
			2.35	2.25	80° P	HAGO	109	10	3-1/2
					80° W	DELANVAN			
					80° W	DELANVAN			

† Air shutter and air band settings shown are approximate ONLY. See STARTUP page 6.

* All burner models shown are single stage.

- NOTE: 1. Extended heads on all units
 2. No static plate for L-50 only.
 3. Insertion depth 2-5/32 for L-30 and L-40; 2-21/32 for L-50.
 4. Air Band: 2 slot for L-30, 4 slot for L-40, 8 slot for L-50

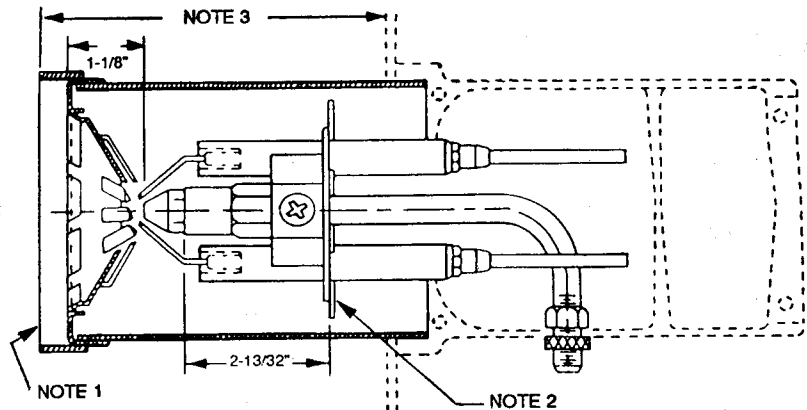
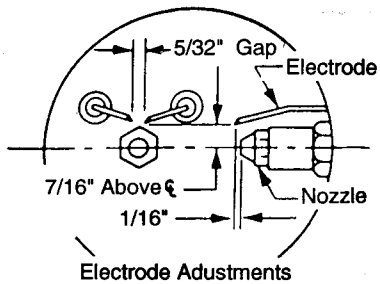

See table for approximate settings.

SHUTTER ADJUSTMENT
 Shutter opens clockwise (right). Example shown at no. 6 position.

(0) is not imprinted on burner, but is the first mark on the left.

EMBOSSED AIR BAND ADJUSTMENT
 Example shown in closed (0) position. Band opens when moved clockwise (right).

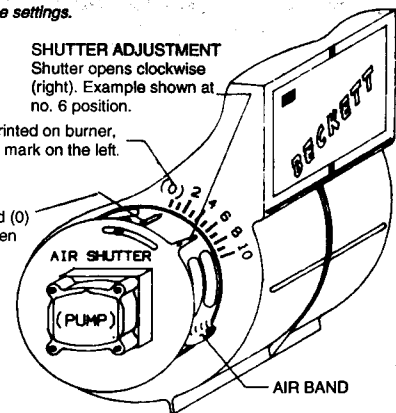

BURNER DATA — RIELLO BURNERS FOR PACKAGED BOILERS ONLY
 (For knocked down & boiler burner units see publication no. L-42KB)

BOILER MODEL	BURNER MODEL *	BURNER DESCRIPTION	FIRING RATE NO.2 OIL (GPH)	NOZZLES			OIL PUMP PRESSURE SETTING (PSIG)	APPROX. AIR SHUTTER SETTING NO.†	APPROX. HEAD SETTING NO.†
				SIZE (GPH)	ANGLE & TYPE	MFR.			
L-30H	40 Series F-5	with short tube	1.00	.75	60° ES	HAGO	178	2.40	0
L-30HF	40 Series F-5	with short tube	.95	.75	60° ES	HAGO	160	2.20	0
L-30	40 Series F-5	with short tube	1.10	.85	70° ES	HAGO	160	4.50	2
					70° B	DELAVAN			
			1.25	1.00	70° ES	HAGO	160	4.00	2
					70° W	DELAVAN			
L-40H	40 Series F-10	with short tube	1.50	1.25	70°B	DELAVAN	145	2.00	0
L-40	40 Series F-10	with short tube	1.60	1.25	60° ES	HAGO	160	2.50	1
					70° B	DELAVAN			
			1.80	1.35	70° ES	HAGO	180	3.00	1
					70° B	DELAVAN			
L-50H	40 Series F-10	with short tube	2.00	1.50	45° B	DELAVAN	178	3.00	1
L-50HF	40 Series F-10	with short tube	1.90	1.50	45°B	DELAVAN	160	2.60	1
L-50	40 Series F-10	with short tube	2.10	1.65	60° W	DELAVAN	160	4.00	2
			2.35	1.75	60° W	DELAVAN	170	4.00	4

† Air shutter and head settings shown are approximate ONLY. See STARTUP page 6.

* All burner models shown are single stage.

NOTE: For proper insertion into combustion chamber see figure 12.

Figure 9A Riello 40 Series

**MODEL F-5
ELECTRODE SETTING**

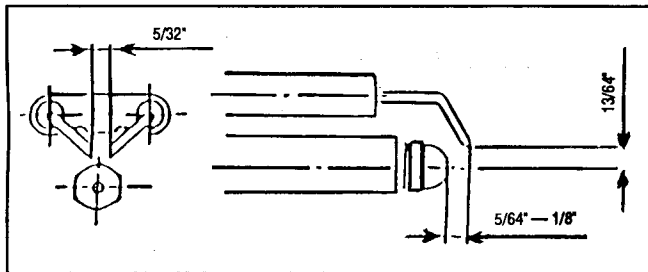
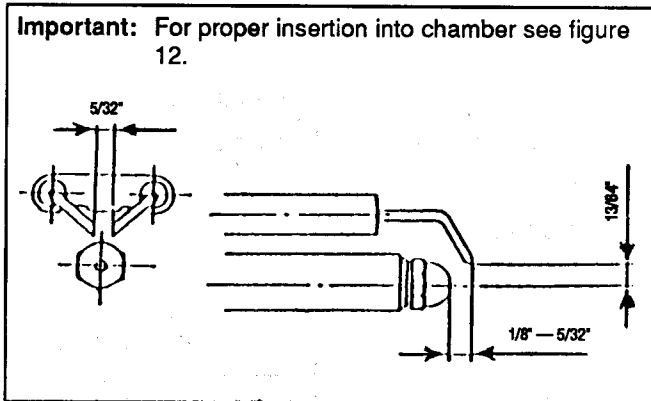

Figure 9B

MODEL F-10
ELECTRODE SETTING



NOTE: ELECTRODES ARE PRESET AT THE FACTORY.
REGULATION OF THE TURBULATOR AND AIR SHUTTER FOR PROPER COMBUSTION

Turbulator Setting

- Loosen nut, 1, then turn the screw, 2, until the index marker, 3, is aligned with the correct index number.
- Retighten the retaining nut, 1.

TURBULATOR SETTINGS - RIELLO 40 SERIES

The numbers on the casting are there to denote the high and low end of the scale — in all cases the first mark if "Zero".

The air/oil ratio depends on accurate setting of the turbulator disc. Be careful when making this adjustment as an incorrect setting will result in an unsatisfactory installation. See figures 10A & B.

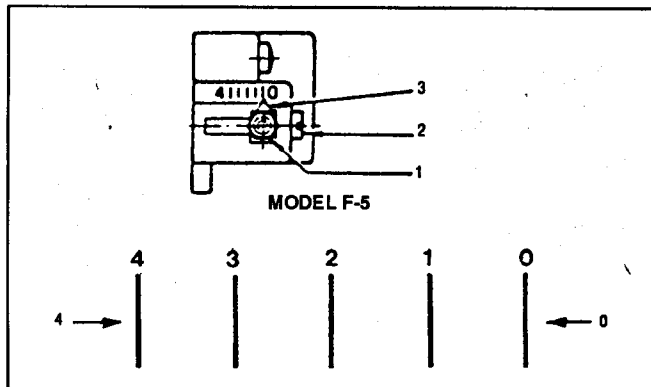
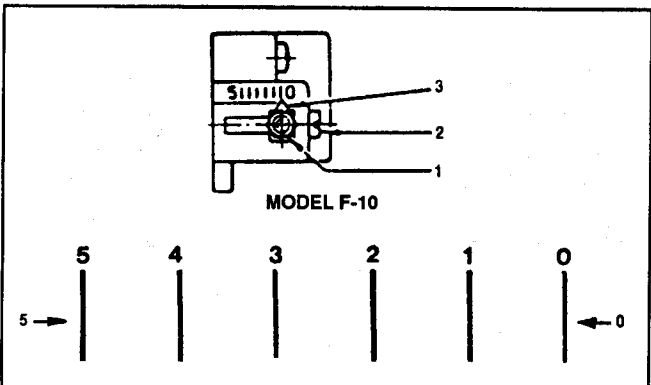
Figure 10A**Figure 10B****SETTING THE AIR ADJUSTMENT PLATE** (See figure 11)

- The hydraulic AIR SHUTTER (A) is operated by the HYDRAULIC JACK (F), assuring complete opening of the combustion air intake. Regulation of the combustion air flow is made by adjustment of the manual AIR ADJUSTMENT PLATE (D) after loosening the FIXING SCREWS (C & E). The initial setting of the air adjustment plate should be made according to page 13.
- The proper number on the manual AIR ADJUSTMENT PLATE (D) should line up with the SETTING INDICATOR (B) on the fan housing cover. Once set, the air adjustment plate should be secured in place by tightening SCREWS C and E. Manually open and release the hydraulic air shutter to ensure it has free movement.
- The final position of the air adjustment plate will vary on each installation. Use instruments to establish the proper settings for maximum CO₂ and a smoke reading of zero.

NOTE: Variations in flue gas, smoke, CO₂ and temperature readings may be experienced when the burner cover is put in place. Therefore, the burner cover must be in place when making the final combustion instrument readings, to ensure proper test results.

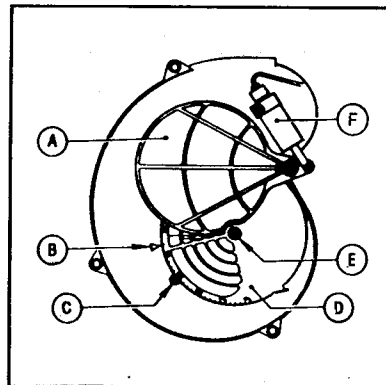
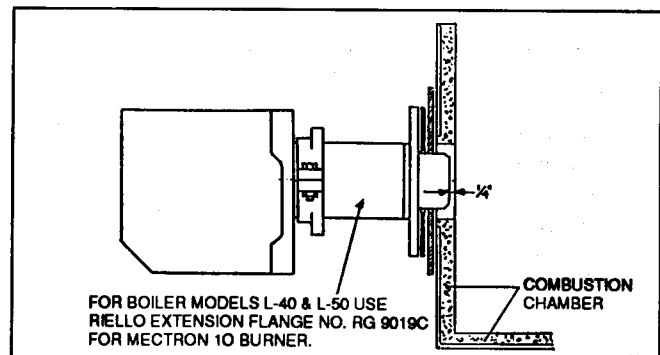
Figure 11**Figure 12****FOR PROPER INSERTION INTO COMBUSTION CHAMBER**

BURNER DATA — WAYNE BURNERS FOR PACKAGED BOILERS ONLY

(For knocked down & boiler burner units see publication no. L-42KB)

BOILER MODEL	BURNER MODEL *	FIRING RATE NO.2 OIL (GPH)	NOZZLES			OIL PUMP PRESSURE SETTING (PSIG)	"A" APPROX. HEAD SETTING†	APPROX. AIR BAND SETTING †
			SIZE (GPH)	ANGLE & TYPE	MFR.			
L-50	EH	2.15	2.00	80° B	DELAVAN	115 (BAR)†	3/8" Back	1/2"
				80° B	DELAVAN	109	1/8" Back	3/4"
		80° P	HAGO					
L-60	EH	2.60	2.50	80° W	DELAVAN	108 (BAR)†	1/8" Forward	3/4"
				80° SS	HAGO	107	1/8" Forward	1-1/8"
		2.85	2.75	80° P	HAGO			
				80° W	DELAVAN			
L-70	EH	3.00	3.00	70° W	DELAVAN	100 (BAR)†	1/8" Forward	1-1/8"
				70° SS	HAGO	107	1/8" Forward	1-1/8"
		3.10	3.00	70° W	DELAVAN	107	1/8" Forward	1-7/8"
				70° W	DELAVAN	125		
				70° SS	HAGO	113		

* Choke 3" (Wayne part no. 12329); Static Disc 2-1/2", 6" air tube; 1-3/4" insertion for the welded flange.

† Burner specifications marked "BAR" are for Liberty boilers approved for use in N.Y.C. by Bureau of Air Resources.

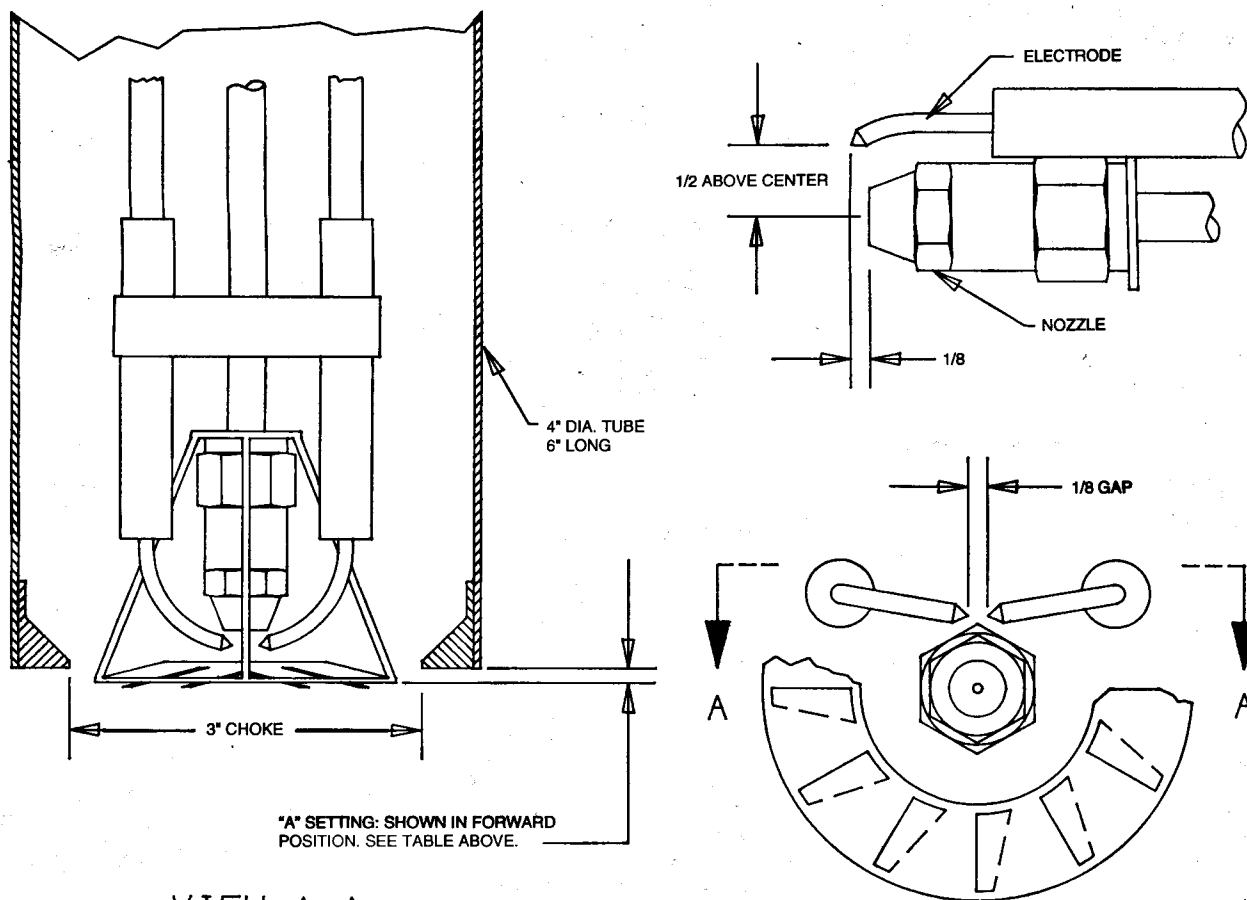

CARE AND MAINTENANCE**I. EXTENDED SHUTDOWN, OR REMOVAL OF BOILER FROM SERVICE.**

- A. Flush sludge from bottom of boiler. While the boiler is still hot (180° to 200° F), drain water from the bottom of the boiler until it runs clear.
- B. Provide corrosion protection to water (this is not scale control):
1. For steam boilers, maintain a *sodium chromate* solution strength of 16 oz. per 50 gallons of water; and refill to the top of the gauge glass.
 2. For water boilers, maintain a *sodium chromate* solution strength of 6 oz. per 50 gallons of water, and refill to normal fill-pressure with system vented.
 3. Raise water temperature to at least 180°F for one hour to release dissolved gases.
 4. Shut down burner by disconnecting the main switch.
- C. Clean boiler heating surfaces thoroughly, down to clean metal.
1. Remove flue and clean thoroughly.
 2. Remove top flue collector to facilitate cleaning soot and scale from the heating surfaces.
To remove the flue collector, the top rear jacket panel must first be removed. The flue collector is held in place by a single carriage bolt and wing nut at the rear of the boiler. Remove the wing nut and pull up firmly on the rear of the flue collector tipping it forward to break the seal between it and the boiler. Then, pull it out from under the lip in the front boiler section.
 3. To gain access to the combustion chamber for cleaning, the burner must be removed. The flexible electrical conduits from the burner to the limit controls are long enough to allow removing the burner without disconnecting them. The cast iron burner mounting plate should be removed along with the burner to completely expose the combustion chamber for thorough cleaning and for inspection of the target wall.
 4. Use the flue brush to clean the pinned flueways between the sections. A wire brush may be used to remove any carbon accumulation that may have developed in the combustion chamber. Vacuum the loose soot and debris from the boiler.
 5. Inspect the refractory target wall in the rear of the combustion chamber. If badly deteriorated, it should be replaced. Inspect the burner combustion head. Clean if necessary and make sure all the adjustments are correct. (See burner data pages for the burner installed.) Replace oil nozzle with a new one. To insure proper burner operation **ONLY THE NOZZLES SPECIFIED IN THIS MANUAL OR ON THE BURNER LABEL SHOULD BE USED FOR REPLACEMENT.**
 6. Protect all of the fireside surfaces by swabbing with neutral mineral oil.
 7. Replace burner and flue collector.
In most cases, the flue collector sealant can be reused. Smooth the sealant in the groove around the top of the boiler sections and under the lip in the front section. Be sure that there are no gaps.
The head of the carriage bolt fits into the slot on the top of the rear section. Insert the front edge of the flue collector under the lip on the front section. Push forward and down on the flue collector, guiding the bolt into the bracket on the flue collector. Add the washer and wing nut and tighten until a proper seal is obtained.
- D. If boiler room is damp, provide ventilation.

II. PROVIDING PROTECTION FOR FREEZING

Anti-freeze is sometimes used in hydronic heating systems to protect against freeze-up in the event of power failure, or safety control shutdown when the building is unoccupied. It should be recognized that unless the building is kept above freezing temperature by some means, the plumbing system is not protected.

Two types of anti-freeze may be used: ETHYLENE GLYCOL, used in automobiles, has desirable properties, but is toxic. Its use may be prohibited when system water/glycol solution is in contact with a potable water vessel (as with a tankless heater). PROPYLENE GLYCOL is used in the quick-freeze food industry; it is practically non-toxic. Its use may be permitted when tankless heaters are used. When anti-freeze must be used, inhibited propylene glycol is recommended. Useful information on the characteristics, mixing proportions, etc. of glycol in heating systems is given in Technical Topics No 2A, available from the Hydronics Institute, 35 Russo Place, Berkeley Heights, N.J. 07922. Consult glycol manufacturers for sources of propylene glycol.

III. OIL BURNER

Inspect and clean annually and following any period of improper operation. Recheck and adjust settings as specified for burner model and nozzle size.

Set burner air and draft regulator, using test instruments to obtain recommended CO₂ and draft without smoke. Refer to page 6.

IV. GENERAL MAINTENANCE

These operations are recommended to be performed at regular intervals:

- A. **BOILER HEATING SURFACES:** clean off all coatings found. Reseal covers.
- B. **BOILER CONTROLS:** check contacts, settings, correct functioning.
- C. **PIPING:** check piping and accessories for leaks.
- D. **CHIMNEY or STUB VENT and BREECHING:** check for obstructions and leaks.
- E. **COMBUSTION AIR TO BURNER:** check for continued POSITIVE supply of air as required. Air needs are greatest in coldest weather. Refer to AIR SUPPLY, page 3.
- F. **WATER SYSTEM:** check
1. System to be full of water and pressure to remain stable (between 12 psi and 25 psi).
 2. Air-control system: noise and air binding in radiation should not occur.
 3. Water lines: slightest leaks should be corrected.
 4. Low water cutoff, for operation (see instructions furnished with unit). See page 7.
- G. **STEAM SYSTEM:** check
1. Low water cutoff, for operation (see instructions furnished with unit). See page 7.
 2. Check pressure cut-off for operation. See page 8.
 3. Any unusual water conditions. Obtain water analysis and treat water.
- H. **BOILER ROOM AIR SUPPLY:** air vents should be open and free of obstruction. See page 3.

† A flue brush (2-1/4" dia.) is supplied with boiler. Replacements are available from dealer or hardware stores.

Slant/Fin®

100 FOREST DRIVE, GREENVALE, NY 11548 (516) 484-2600

PARTS LIST



PACKAGED CAST-IRON OIL BOILERS

Table 1: WATER BOILER PARTS LIST, P AND PT

ITEM	DESCRIPTION	QTY	L-20	L-30	L-40	L-50	L-60	L-70
1A	Casting subassembly water, less plate	1	430712	430713	430714	430715	430716	430717
1B	Casting subassembly water, extended boss less plate	1	430712	430713	430714	430715	430716	430717
1C	Casting subassembly water, solid front (NO provision for tankless)	1	430702	430703	430704	430705	430706	430707
2	Bumer mounting plate C.I.	1	430014	430014	430014	430014	430014	430014
3	Front refractory insulation	1	430018	430018	430018	430018	430018	430018
4	Target wall	1	430029	430029	430029	430029	430029	430029
4A	Blanket, insulation	1	—	—	—	—	430059	430060
5	Stud 3/8-16 x 1-7/8 steel interrupted thread	4	430115	430115	430115	430115	430115	430115
6	Sealant material 1/4" dia. 50" long, mtg. plate	1	430136	430136	430136	430136	430136	430136
7	Hex nut 3/8-16 steel	7	400328	400328	400328	400328	400328	400328
8	Washer flat 3/8 nom. steel	13	430117	430117	430117	430117	430117	430117
9	Blank plate, tankless	1	430031	430031	430031	430031	430031	430031
10	Gasket 1/8 thick	1	430071	430071	430071	430071	430071	430071
11	Cap screw 3/8-16 x 3/4 lng. hex hd.	6	400200	400200	400200	400200	400200	400200
12	Flue collector	1	430032	430033	430034	430035	430036	430037
12A	Flue collector sealant	1	430137	430137	430137	430137	430137	430137
13	Carriage bolt 1/4-20 x 2-1/2 long	1	430108	430108	430108	430108	430108	430108
13A	Wing nut 1/4-20	1	400147	400147	400147	400147	400147	400147
13B	Washer 1/4"	1	909783071	909783071	909783071	909783071	909783071	909783071
14	Clean out door CRS	1	430019	430019	430019	430019	430019	430019
15	Observation door C.I.	1	402185	402185	402185	402185	402185	402185
16	Self tapping screw, 1/4-20 x 1 long hex slotted hd.	3	400217	400217	400217	400217	400217	400217
17	Stud 3/8-16 x 1-3/8 steel interrupted thread	3	430107	430107	430107	430107	430107	430107
18	Jacket, insulated top	1	430362	430363	430364	430365	430366	430367
19	Jacket, insulated side	2	430372	430373	430374	430375	430376	430377
20	Jacket, insulated rear	1	430371	430371	430371	430371	430371	430371
21	Jacket, insulated front, water	1	430370	430370	430370	430370	430370	430370
22	Emblem - Slant/Fin	1	401020	401020	401020	401020	401020	401020
24	Sheet metal screw #8 x 3/8 AB hex slot hd.	14	908116021	908116021	908116021	908116021	908116021	908116021
25	Relief valve - H.W. 30 PSI Conbraco or Watts	1	400103	400103	400103	400103	400103	400103
26	Nipple 3/4 x 2 long (for relief valve)	1	400225	400225	400225	400225	400225	400225
27	Drain valve 3/4 NIBCO #74	1	400201	400201	400201	400201	400201	400201
28	Reducing bushing 1-1/2 NPT x 3/4 NPT	1	902179321	902179321	902179321	902179321	902179321	902179321
29	Tridicator (0-75 PSI)	1	910373061	910373061	910373061	910373061	910373061	910373061
30	Control, hi limit Hon. L4080B1253 or W/R11B83-1	1	—	—	—	—	—	410699
30A	Control, high/low limit L4081A (PT)	1	—	—	—	—	410529	410529
30B	Control, hi limit circ. HON L8148A (P)	1	400096	400096	400096	400096	400096	—
30C	Control, hi-lo limit-circ. HON L8124C1094 (PT)	1	400095	400095	400095	400095	—	—
31	Well 1/2 NPT x 1-1/2 ins.	1	410569	410569	410569	410569	410569	410569
32	Thermostat - 24V Hon. T822D1537	1	—	400101	400101	400101	400101	400101
33	Primary control, Honeywell R8184G	1	400119	400119	400119	400119	400119	N.A.
34	Bumer assembly: Beckett	1	—	4301532	4301542	4301552	—	—
34A	Bumer assembly: Carlin	1	4301530	4301530	4301540	4301550	4301560	4301570
34B	Bumer assembly: Riello	1	—	4301533	4301543	4301553	—	—
35	Tankless heater assy. (optional)	1	430082	430083	430084	430084	430085	430085
36	Gasket, Beckett bumer	1	—	430172	430172	430172	—	—
36A	Gasket, Carlin bumer	1	430173	430173	430173	430173	430173	430173
37A	Circulator, Taco 007-F4	1	7902022	7902022	7902022	7902022	7902022	7902022
37B	Circulator, Grundfos UP-15-42F	1	7902021	7902021	7902021	7902021	7902021	7902021
37C	Circulator, B&G SLC30	1	7902023	7902023	7902023	7902023	7902023	7902023
37D	Circulator, Taco 0010	1	—	—	—	430102	430102	—

Table 2. STEAM BOILER PARTS LIST, PZ AND PZT

ITEM	DESCRIPTION	QTY	L-30	L-40	L-50	L-60	L-70
1	Casting subassembly steam, less plate	1	432033	432034	432035	432036	432037
2	Bumer mounting plate C.I.	1	430014	430014	430014	430014	430014
3	Front refractory insulation	1	430018	430018	430018	430018	430018
4	Target wall	1	430029	430029	430029	430029	430029
5	Stud 3/8-16 x 1-7/8 steel interrupted thread	4	430115	430115	430115	430115	430115
6	Sealant material 1/4" dia. 50" long, mtg. plate	1	430136	430136	430136	430136	430136
7	Hex nut 3/8-16 steel	7	400328	400328	400328	400328	400328
8	Washer flat 3/8 nom. steel	19	430117	430117	430117	430117	430117
9	Blank plate, tankless steam	1	430021	430021	430021	430021	430021
10	Gasket 1/8 thick	1	430070	430070	430070	430070	430070
11	Cap screw 3/8-16 x 3/4 long hex hd.	12	400200	400200	400200	400200	400200
12	Flue collector	1	430033	430034	430035	430036	430037
12A	Flue collector sealant	1	430137	430137	430137	430137	430137
13	Carriage bolt 1/4-20 x 2-1/2 long	1	430108	430108	430108	430108	430108
13A	Wing nut 1/4-20	1	400147	400147	400147	400147	400147
13B	Washer 1/4"	1	909783071	909783071	909783071	909783071	909783071
14	Clean out door CRS	1	430019	430019	430019	430019	430019
15	Observation door C.I.	1	402185	402185	402185	402185	402185
16	Self tapping screw, 1/4-20 x 1 long hex slotted hd.	3	400217	400217	400217	400217	400217
17	Stud 3/8-16 x 1-3/8 steel interrupted thread	3	430107	430107	430107	430107	430107
18	Jacket, insulated top	1	430363	430364	430365	430366	430367
19	Jacket, insulated side	2	430373	430374	430375	430376	430377
20	Jacket, insulated rear	1	430371	430371	430371	430371	430371
21	Jacket, insulated front, steam	1	430360	430360	430360	430360	430360
22	Emblem - Slant/Fin	1	401020	401020	401020	401020	401020
24	Sheet metal screw #8 x 3/8 AB hex slot hd.	14	908116021	908116021	908116021	908116021	908116021
25	Safety valve Conbraco 13-501 or Watts 315	1	400107	400107	400107	400107	400107
26	Water gauge set 1/2 NPT	1	402036	402036	402036	402036	402036
27	Glass - 5/8 dia. x 5-3/4 long	1	430132	430132	430132	430132	430132
28	Rod - 3/16 dia. x 7-3/4 long	2	430134	430134	430134	430134	430134
29	Pressure gauge - 30 PSI 2-1/2	1	910374051	910374051	910374051	410374051	910374051
30	Pressuretrol PA404A1009	1	400117	400117	400117	400117	400117
31	Siphon - 1/4 NPT	1	400222	400222	400222	400222	400222
32	Tee - 1/4 x 1/4 x 1-1/4 brass	1	400223	400223	400223	400223	400223
33	Nipple - 1/4 x 2-1/2 long	1	400224	400224	400224	400224	400224
34	Nipple - 1/4 x close brass	1	400240	400240	400240	400240	400240
35	Elbow - 1/4 x 90 deg. brass	1	400232	400232	400232	400232	400232
36	Drain valve 3/4	1	400201	400201	400201	400201	400201
37	Reducing bushing - 1-1/2 NPT x 3/4 NPT	1	902179321	902179321	902179321	902179321	902179321
38	Plug square hd. - 1-1/2 NPT (skimmer tapping)	1	902342051	902342051	902342051	902342051	902342051
39	Thermostat - 24V hon T822D1537	1	400101	400101	400101	400101	N.A.
40	Primary control, White-Rodgers no. 668-415	1	4001191	4001191	4001191	4001191	N.A.
	Primary control, Honeywell R8184G	1	400119	400119	400119	400119	N.A.
41	Bumer assembly, see #34 table 1	1	—	—	—	—	—
42	Tankless heater assy. (optional)	1	430080000	430080000	430080000	430080000	430080000
43	Control, low limit Honeywell L4006A2049(optional)	1	410527	410527	410527	410527	410527
44	Well 1/2 NPT x 1-1/2 ins. (optional)	1	410569	410569	410569	410569	410569
45	Plug 3/4 (for alternate L.W.C.O.)	1	902340051	902340051	902340051	902340051	902340051
46	Low water cut-off M&M PS 801-120 (optional)	1	430130	430130	430130	430130	430130
47	Low water cut-off M&M 67 (standard)	1	400116	400116	400116	400116	400116
48	Gasket, Beckett bumer	1	430172	430172	430172	—	—
48A	Gasket, Carin bumer	1	430173	430173	430173	430173	430173

**DETAIL OF CLEAN OUT AND
OBSERVATION DOOR ASSEMBLY**

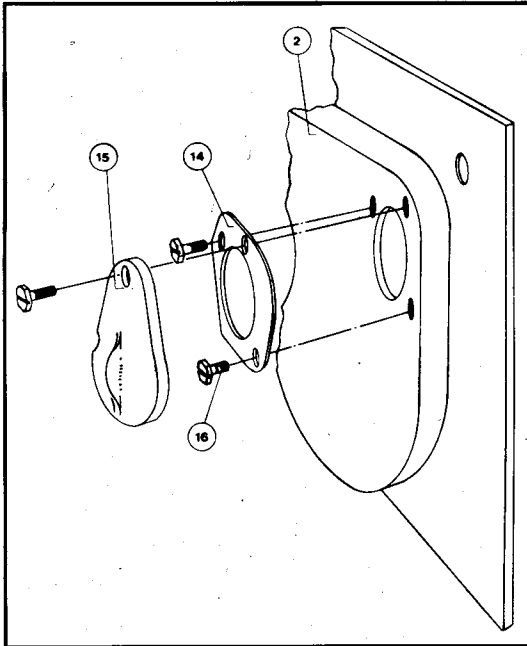

Figure 3

Slant/Fin

SLANT/FIN CORPORATION, 100 Forest Drive, Greenvale, New York 11548 • (516) 484-2600