

# FUJICA STX-1n

Fujica MPF105X

This camera manual library is for reference  
and historical purposes, all rights reserved.

This page is copyright by M. Butkus, NJ.  
This page may not be sold or distributed  
without the expressed permission of the producer  
On-line camera manual library

**If you find this manual useful, how about a donation of \$3 to:**

**M. Butkus, 29 Lake Ave., High Bridge, NJ 08829-1701**

**This will help me to continue to host this site,  
buy new manuals, and pay their shipping costs.  
It'll make you feel better, won't it?**

For PAYPAL use

[www.PayPal.me/butkus](http://www.PayPal.me/butkus)

Venmo is @mike-butkus-camera

**<<< IF YOU WOULD LIKE THIS OR ANY PDF FILE PRINTED, BOUND AND  
MAILED TO YOU, SEE THIS OUTSIDE COMPANY'S OFFER >>>**

**[Back to my main camera information page](#)**

---

**This STX-1n is basically the same as the [STX-1](#) but has an LED meter lights  
rather than the delicate needle meter. See below for instruction on  
using and checking the battery with the LED (STX-1N) model**



## CONTENTS

<p><b>Part 1, Fundamentals</b></p> <p>Names and Functions of Parts.</p> <p>Special Features</p> <p>1. Basic Steps.</p> <p>2. Battery Insertion . . .</p> <p>3. Film Loading .</p> <p>4. Setting the Film Speed. .</p> <p>5. Setting the Shutter Speed .</p> <p>6. Focus the Lens and Frame Your Picture</p> <p>7. Correct Exposure .</p> <p>8. Holding the Camera and Releasing the Shutter ... ....</p> <p>9. Rewinding Film and Unloading Film</p>	<p><b>Part 2, Advanced Techniques</b></p> <p>1 Changing the Lens .. ....</p> <p>2. Exposure Correction : . . .</p> <p>3. Utilizing the Lens Depth of Field</p> <p>4. Using the Self Timer. ...</p> <p>5. Infrared Photography</p> <p>6. Taking flash pictures</p> <p>7. Accessories for the FUJICA STX-1n</p> <p>8. Care and Storage of your FUJICA STX-1n</p> <p>9. Specifications</p>
--	---

## **Names and functions of the parts**

- 1. Film Advance Lever**
- 2. Shutter Speed Selector Dial/ASA film speed selector**
- 3. Film ASA Speed Window**
- 4. Shutter Release Button provided with socket for**
- 5. Frame Counter (Additive type automatically resets)**
- 6. Shutter Speed Mark (red dot)**

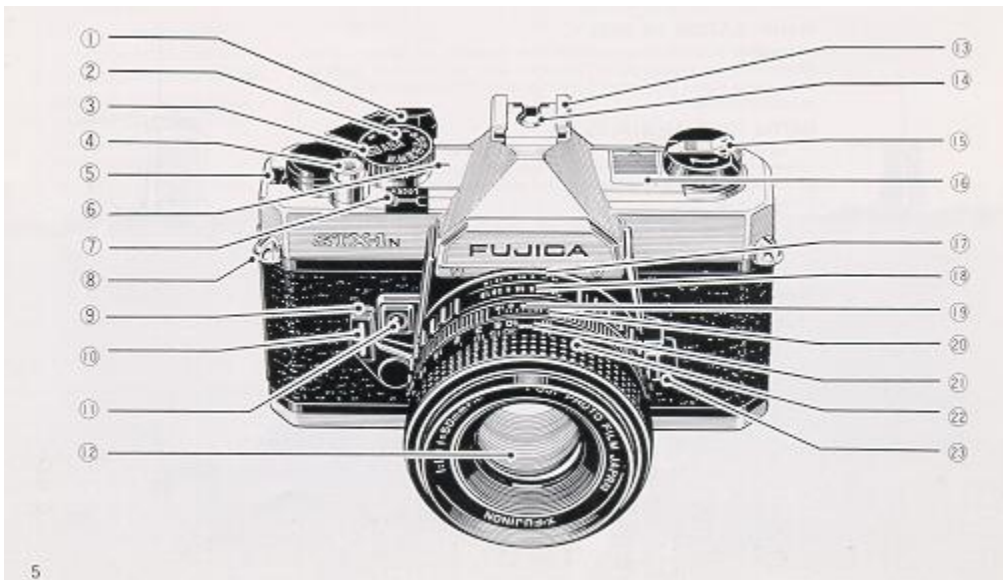

- 7. Shutter Release. Lock**
- 8. Neck strap Eyelet**
- 9. Self-timer Start Button.**
- 10. Self-timer Set Lever (The shutter is activated in 8 - 10seconds)**
- 11. Depth of Field Preview Button**
- 12. Taking Lens**
- 13. Accessory (hot) Shoe**
- 14. Hot Shoe for X Contact**
- 15. Combination Rewind Crank/Camera Back Lock**
- 16. Battery Chamber / Insert two alkaline-manganese batteries (LR44) for powering the camera's electric Metering system (mercury batteries (HR44) or silver-oxide batteries (SR44) can also be used)**

**17. Lens Mount**

**18. Aperture Selector Ring**

**19. Aperture / Distance Mark**

**20. Depth of Field Indicator**

**21. Distance Scale**

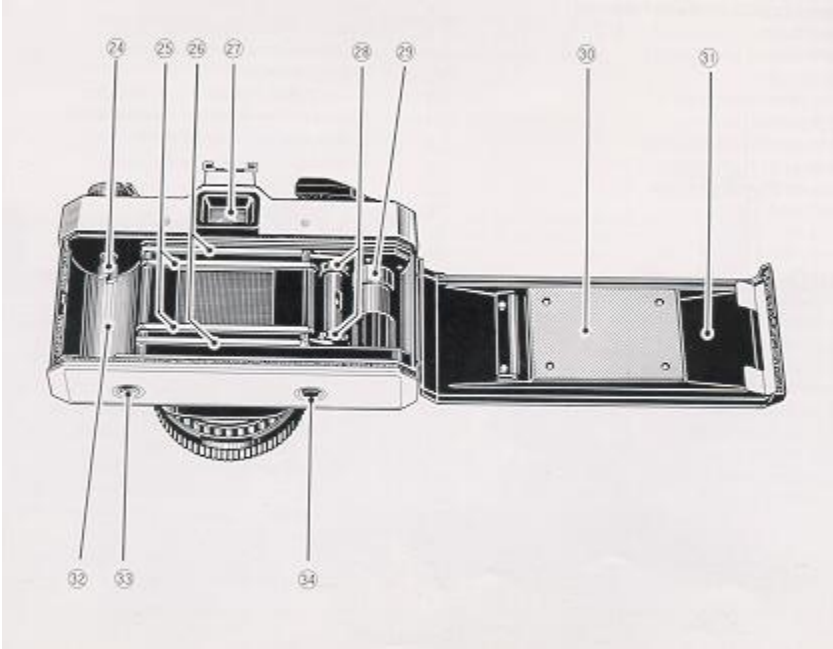

**22. Focusing Ring**

**23. Lens Safety Lock**

**24. Film Rewind Spindle**

**25. Film Rail**

**26. Guide Rail (the film is passed over the film rail and the edges go between the Guide Rail)**

**27. Viewfinder Eyepiece designed for attaching the Eye Cup. etc.**

**28. Battery Chamber / Insert two alkaline-manganese batteries (LR44) for powering the camera's electric Metering system (mercury batteries (HR44) or silver-oxide batteries (SR44) can also be used).**

**29. Sprocket Wheel ( The film perforations are engaged with the sprocket teeth to advance the film. )**

**30. Take-up Spool**

**31. Pressure Plate**

**32. Camera Back**

### **33. Film Chamber**

### **34. Tripod Socket**

### **35. Film Rewind Button**

## **SPECIAL FEATURES**

### **1. Improved Through-The-Lens Exposure Meter**

The exposure meter of the FUJICA STX-1n consists of 2 Silicon photocell light receptors located on either side of the viewfinder eyepiece. which are connected to an FET (Field Effect Transistor) circuit and are coupled with the shutter and diaphragm. It measures the average light intensity which falls on the entire surface of the focusing glass In other words, it measures the light that has passed through the lens and will actually reach the film.

Special features of this camera are: the new Fujica X bayonet mount which permits quick interchanging of the lenses, a full aperture metering system. and three-way focusing with split image, microprism and ground glass It is also provided with a shutter speed indicator scale in the viewfinder to enable you to set the shutter speed while looking through the viewfinder

### **2. World Renowned X-FUJINON Lens**

The interchangeable lenses of the FUJICA STX-1n are widely known for their superb color definition and perfect corner-to-corner picture sharpness and clarity.

### **3. A Complete Camera System in Itself**

A wide range of interchangeable lenses, accessories. and its Improved TTL full-aperture exposure meter make the FUJICA STX-1n a complete camera system in itself capable of handling any picture-taking situation and subject.

## **BASIC STEPS**

### **1. Load the Film**

**Pull the Combination Film Rewind Crank/Back Cover Lock fully until the Camera Back automatically snaps open Next, load the 35mm film cartridge into the Film Chamber and insert the film into the slot of the Take-up Spool.**

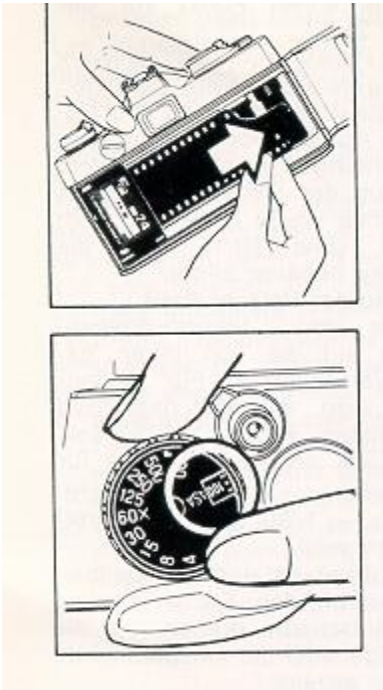

## 2. Set the Film Speed

To set the camera for the speed of the film you are using, pull up the top of the Shutter Speed Selector Dial and turn it until the number you want appears in the center of the ASA Film Speed Indicator Window

## 3. Set the Frame Counter to 1 (the first white dot before the number 2)

The odd numbers of the frame counter are represented by white dots. Wind the Film Advance Lever and press the Shutter Release Button Do this twice. and on the 3rd winding. the first white dot on the film counter (frame No 1 ) will move opposite the triangular mark.

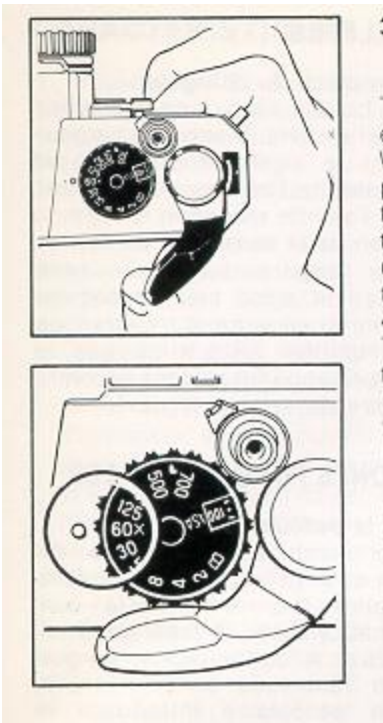

#### **4. Set the Shutter Speed Selector Dial**

**Turn the Shutter Speed Selector Dial to the speed desired If you are shooting outdoors. the shutter speed will be either 1/125 sec or 1/250 see If you are shooting indoors it will be 1/30 sec or 1/60 sec The shutter speed can also be set with the shutter speed scale and green indicator needle in the viewfinder (left side edge) The needle is set by turning the Shutter Speed Selector**

#### **5. Focus the Lens and Frame Your Picture**

**(1) Look through the Viewfinder Eyepiece and turn the Focusing Ring to focus and frame your picture**

**(2) To focus turn the focusing ring to make the upper and lower segments of the split image in the microprism center spot converge and form a perfect fit**

#### **6. Set the exposure**



**To set the camera for correct exposure, press the Shutter Release Button halfway down. Look through the Viewfinder and, while watching the exposure meter needle, turn the Aperture Selector Ring to bring the needle into the center of the indentation**

#### **7. Press the Shutter Release Button**

**Hold camera steady to prevent shake and gently press the Shutter Release Button**

## 8. Rewind the Film



After you have exposed the entire roll of film, press the Film Rewind Button, erect the Film Rewind Crank, and turn it in the direction pointed by the arrow and wind the film back into the cartridge, until you feel tension released. Next, lift the Back Cover Lock fully up until the camera back snaps open. Now, remove the cartridge.

## BATTERY INSERTION

### 1. Open the Cover

Open the Battery Chamber Cover (16) by sliding it in the direction of the arrow.

### 2. Load the Batteries

Insert two alkaline-manganese batteries. One on top of the other into the Battery Chamber with the plus sides (+) facing outward and close the cover.

· If you are buying new batteries, be sure to specify LR44-type alkaline-manganese batteries, HR44-type mercury batteries (extremely hard to find - not worth it), or SR44-type silver oxide batteries.

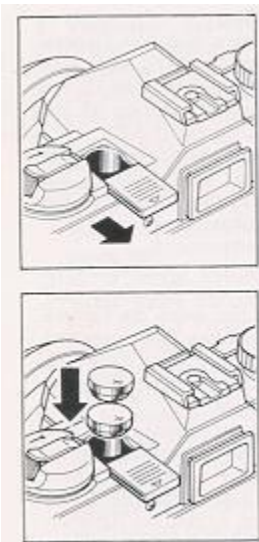



### 3. Check the batteries

(1 ) Set the ISO/ASA Speed Selector (2) to 100, the Shutter Speed Selector (2) to 60, and the Aperture Selector (18) to the maximum aperture (F1.9)



(2) While pressing the Shutter Release Button (4) halfway down, look through the viewfinder and point the camera toward bright light (fluorescent light, etc.)

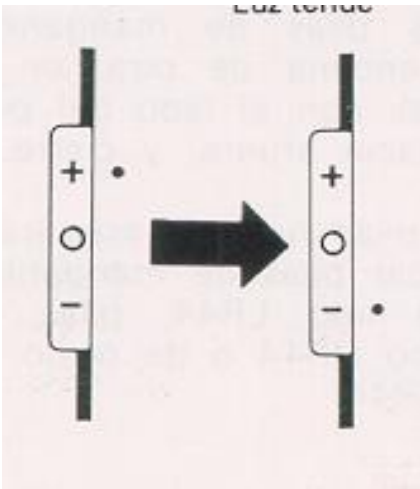

(3) If the LED in the viewfinder moves from the plus side down to the minus side when the camera is faced toward dim light (you can block out the light with your hand), the batteries are loaded properly

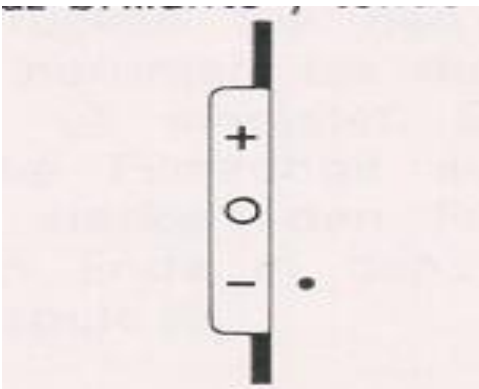

(4) If the LED remains stationary on the plus side or minus side when the camera is faced from bright to dim light. the batteries are either exhausted or improperly loaded and have to be changed or reloaded properly

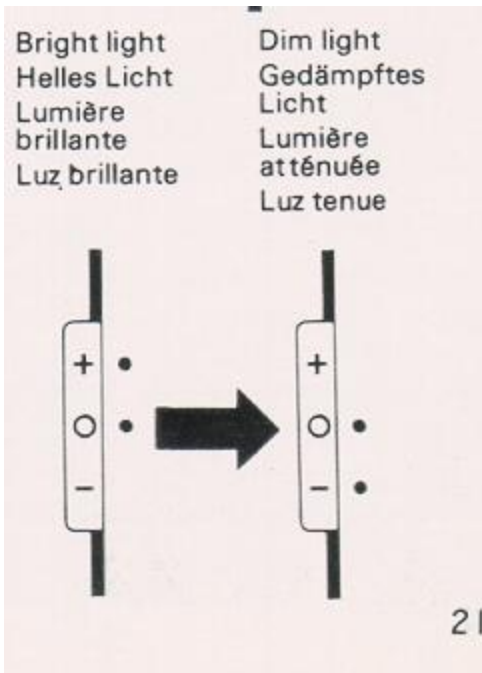

**Precautions:** If you are not taking pictures immediately, lock the shutter release button to prevent tripping the shutter or draining the batteries inadvertently

\* The alkaline-manganese batteries will normally last about 8 months, and mercury or silver-oxide batteries about 1 year

\* If you are not using the camera for a long while, remove the batteries and keep them where it is dry

\* Be sure to wipe both ends of the batteries clean with a piece of cloth before loading. Poor contact may result if the ends are unclean

## FILM LOADING

### 1. Open the Camera Back

Lift the Combination Film Rewind Crank - Camera Back Lock ~ fully up until the Camera Back ~ automatically snaps open.

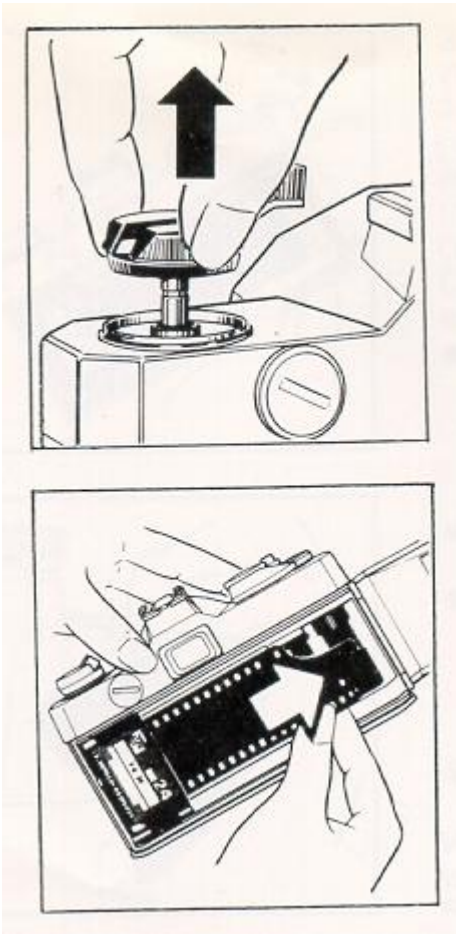

## 2. Load the Film

Insert the cartridge into the Film Chamber ~ with the spool head (projection) pointing to the bottom of the camera. push down the Combination Film Rewind Crank - Camera Back Lock ~ to engage the Film Rewind Spindle ~ with the film spool Pull out the trimmed end of the film and insert it down to the bottom end into the slot of the Take-up Spool by

## 3. Close the Camera Back

Wind the film a little with the Film Advance Lever Expand engage the perforations on both edges of the film with the sprocket teeth Be sure the film is properly inserted between the Guide Rail ~ Now, press down the Camera Back until it closes tightly with a click

\* If the Film Rewind Crank turns in the opposite direction of the arrow as you wind the Film Advance Lever

\* it means the film has been loaded properly,

\* The odd numbers of the Film Counter (hi) are represented by white dots

\* To allow you to take quick shots in succession, the Film Advance Lever (A) will be back with a slight latitude Press it all the way back after you have finished shooting

4. Set the Frame Counter (5) to 1 (the first white dot before the number 2) Wind the Film Advance Lever (1) all the way to the right and press the Shutter Release Button (4) Do this twice, and on the third winding. the first white dot before the number 2 will move opposite the triangular mark You are now ready to take the first picture

### SETTING THE FILM SPEED

Lift the top of the Shutter Speed Selector Dial (2) and turn it to the left or right until the film speed number you want appears in the center of the ASA Film Speed Indicator Window (3)

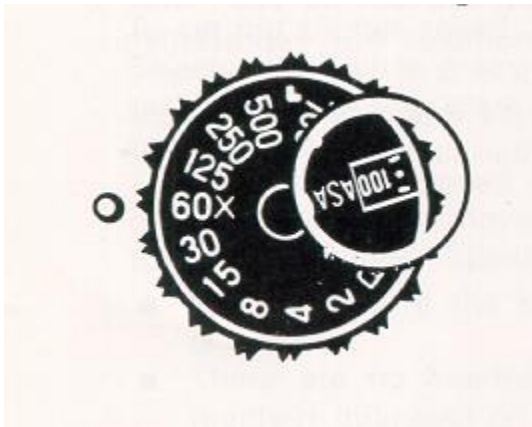

The film speed is printed on the film box. (FUJICOLOR Film FUJICHROME 100 and NEOPAN SS are ASA 100 films FUJICHROME 400 FUJICOLOR 400 and NEOPAN 400 are ASA 400 films )

The calibrations between the ASA numbers represent the following numbers: ( I )

· If you are using a film marked for DIN speed refer to the following conversion table (11)

(I)

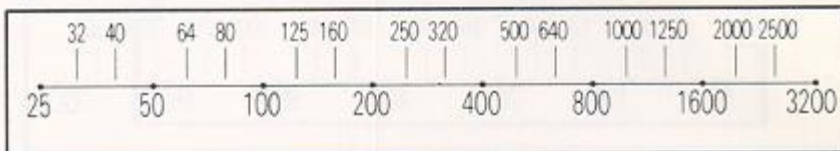

(II)

ASA	25	32	40	50	80	100	200	250	320	400
DIN	15	16	17	18	20	21	24	25	26	27

## SETTING THE SHUTTER SPEED

The letter **B** and the numbers 2... 700 on the Shutter Speed Selector Dial represent "bulb" and 1/2 . ., 1/700 second They indicate the length of time the film will be exposed to light. The shutter speed scale is also visible in the viewfinder (left side edge).



This camera allows you to set exposure either by the shutter speed or by the size of the lens opening However, it is best to set the shutter speed first. For example, the shutter speed would be from 1/125 to 1/250 sec if you are shooting outdoors, or from 1/30 sec to 1/60 sec . if you are shooting indoors To set the shutter speed, first turn the Shutter Speed Selector Dial while pressing down on it slightly and set the number you want opposite the red dot on the camera body. To set the shutter speed with the scale and needle in the viewfinder. just move the needle into position by turning the Shutter Speed Selector. \* Use B (bulb) if the exposure will take 1 second or longer.

\* There are no intermediate settings between the numbers indicated on the dial.

\* 60 is marked with a red X to remind you that it IS the speed used for shooting with electronic flash.

Excepting 1/700 second, each shutter speed is either 1/2 or 2 times the speed of the shutter speed next to it

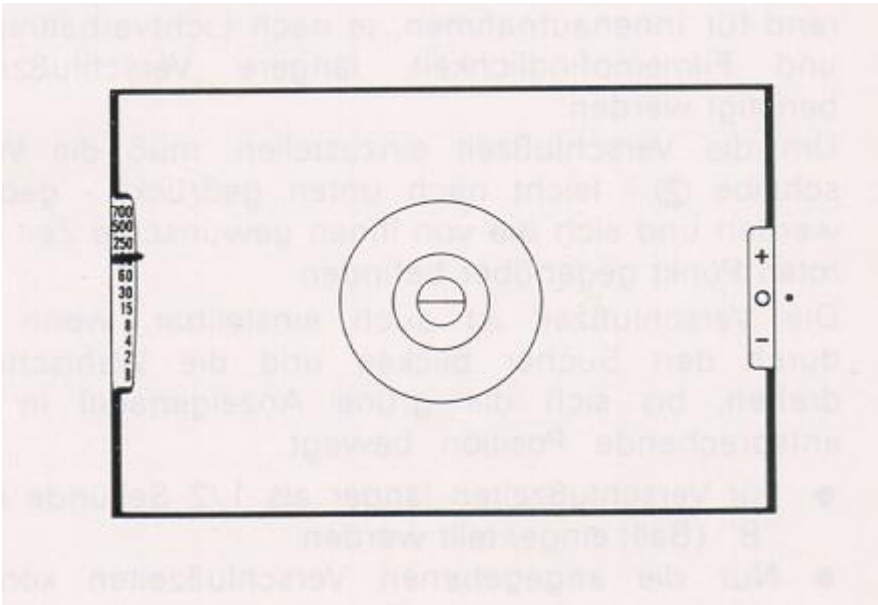

## **FOCUS THE LENS AND FRAME YOUR PICTURE**

### **1. Focus the Lens**

**(1 ) Look through the Viewfinder and point the camera so that the main subject is seen through the small microprism center spot.**

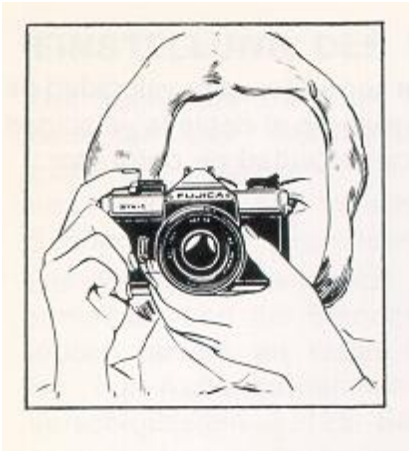

### **(2) Split-image Focusing**

**Turn the Focusing Ring (22) until the upper and lower segments of the split image in the microprism center spot converge to form a single image**

### **(3) Microprism Focusing**

**Turn the Focusing Ring until the image in the microprism center spot appears sharp**

**(4) You can also focus with any part of the area surrounding the microprism center spot This method is especially useful when shooting with aperture stopped far down**

(5) The white numbers on the Focusing Ring are for meters and the green numbers are for feet  
The distance can also be set by visual judgment for quick shooting

When shooting extreme close-ups the distance from subject to Film Plane Mark (16) must be precisely measured with a tape measure

## 2. Frame Your Picture

The Viewfinder will let you see 92% of the entire View that will register on your film so that you can go ahead and use the whole length and width of the area in the Viewfinder to frame your picture

### \* Eyesight Adjustment Lens

The Viewfinder is provided with an eyepiece for those with normal vision. If you are near sighted or far sighted, be sure to use an Eyesight Adjustment Lens, otherwise it will be extremely difficult for you to focus the lens precisely. Four different Eyesight Adjustment Lenses are supplied as optional accessories: +2, +0.5, - 2.5 and ~4 diopter.

## CORRECT EXPOSURE

### 1. Press the Shutter Release Button halfway down

Point the camera at your subject while looking through the Viewfinder and press the Shutter Release

Button (4) halfway down. You will see an LED turn on in the Viewfinder right side

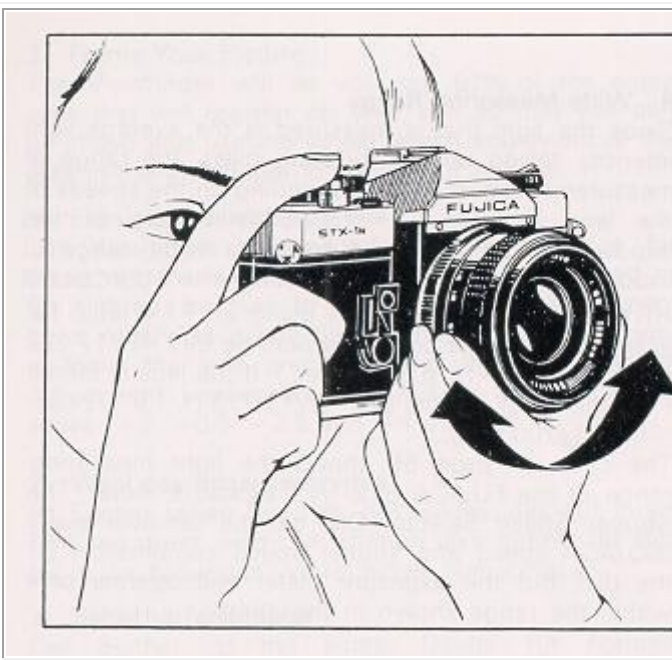

9

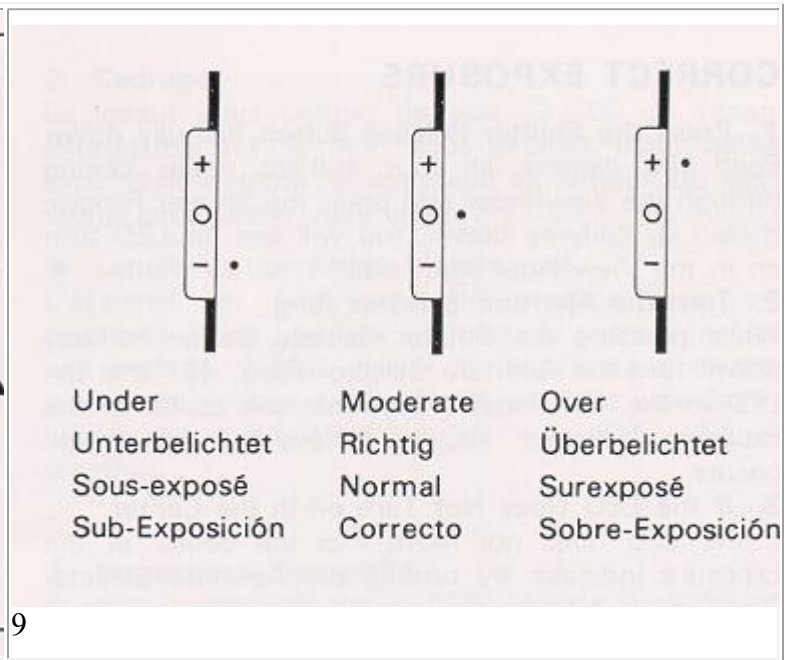

## **2. Turn the Aperture Selector Ring**

**While pressing the Shutter Release Button halfway down, turn the Aperture Selector Ring (18) until the LED in the viewfinder moves into the center of the Exposure Indicator. You now have the correct exposure.**

## **3. If the LED Does Not Turn on in the Center . . .**

**If the LED does not move into the center of the Exposure Indicator by turning the Aperture Selector Ring, you will have to change the shutter speed · If the LED lights on the (+) side, increase the shutter speed (Example: If the shutter speed is 1/125 sec, turn the dial to 1/250 sec.)**

**· If the LED lights on the ( - ) side, reduce the shutter speed. (Example: If the shutter speed is 1/125 sec, reduce it to 1/60 sec ).**

## **4. Wide Measuring Range**

**Since the light that is measured is the average light intensity falling on the focusing glass, the range of measurement must differ depending on the speeds of the lens and film A noteworthy feature of this exposure meter is that it covers a wide range of exposure values If you are shooting with FUJICOLOR HR100 (ISO/ASA 100) film using an F1 4 lens, for example, the range covered would be EV2~EV17-2/3 (f /1.4 1/2 sec of /16 1/700 sec ). If the lens is 50mm F1 9, the range is from EV3~EV17-2/3 (f/1.9 1/2 sec ~f/16 1/700 sec.):**

**The chart on page 56 shows the light measuring range of the FUJICA STX-IN's exposure meter The Shutter Speed Selector Dial can be set over every ISO/ASA speed and shutter speed combination on the dial. but the exposure meter will operate only within the range shown in the chart**

**Note: The aperture can also be set intermediately between the calibrations on the scale to permit fine adjustments.**



## HOLDING THE CAMERA AND RELEASING THE SHUTTER

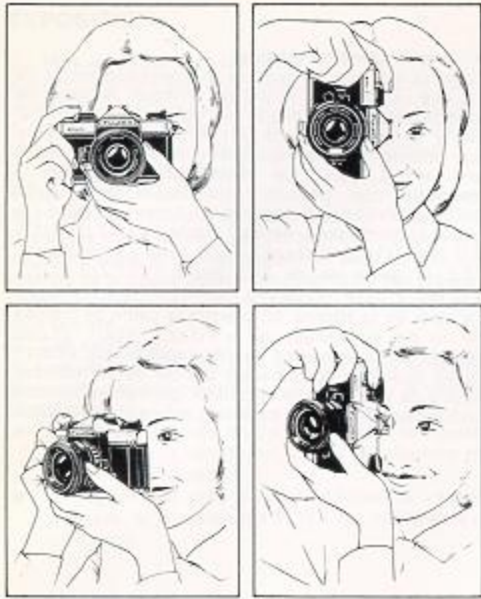

### 1. Hold the Camera Steady

If you don't hold the camera steady, your pictures will not turn out sharp because the camera will shake. Be sure to hold yourself in good balance with elbows close against your body and the camera pressed lightly against your face. This is all the more necessary if you are shooting with the camera held vertically. Practice a little and get used to these motions.

### 2. Press Down the Shutter Release Button

Be sure to press down the Shutter Release Button (hi) gently. Any jerky motion can cause the camera to shake and pictures to be unsharp.

### 3. When To Use a Tripod

If you are taking a close-up, telephoto shot, or if you are shooting at a shutter speed slower than 1/30 sec., be sure to use a tripod and cable release to avoid camera shake.

A cable release is also recommended for shooting long-exposure shots with the camera placed on a table, against a tree, or on some other steady foundation. A cable release with a stopper attachment is a very convenient item for shooting with the camera set at B (bulb). You can press open the shutter, hold it in that position with the stopper for as long as you want, then release the stopper to close the shutter.

## REWINDING FILM AND UNLOADING FILM



After you have finished a roll of film, rewind it back into the cartridge and take it out of the camera

### 1. Press the Film Rewind Button

First, press down the Film Rewind Button (35) located on the underside of the camera. Once you have pressed down this button, you can let it go because it will stay depressed. The Sprocket Wheels (29) are now free.

### 2. Turn the Film Rewind Crank



Erect the Film Rewind Crank (15) and wind it in the direction of the arrow to return the exposed film back into the cartridge. Just before the end of the film is reached, you will feel a slight tension released on the crank. Give it 2 more turns and the film is wound back into the cartridge.

If the film cannot be rewound (this will sometimes happen if the Film Advance Lever is not in the correct position), just depress the Rewind Button and, while holding it down, wind the Film Advance Lever all the way through. Next, release the Rewind Button and rewind the film.

### 3. Open the Camera Back

Lift the Combination Film Rewind Crank - Camera Back Lock (15) until the Camera Back (32) opens with a snap. Now take out the cartridge and send it to the processor - the sooner the better.

Be sure to load and unload the cartridge in the shade and away from direct sunlight by all means. If the end of the film is reached when you have wound the Film Advance Lever half-way around, do not force it because the film might break. Simply press the Film Rewind Button and wind the Film Advance Lever all the way back. The shutter will be wound, but the film will remain stationary. Since you have already pressed the Film Rewind Button, all you need do is turn the Film Rewind Crank.

## CHANGING THE LENS

A complete range of highly color-compatible, high resolution X-FUJINON interchangeable lenses are available for shooting scenic, portraits, snap-shots, news photos, and photo records with the FUJICA STX-1n

### 1. Mounting

Fit the Lens into the camera's Lens Mount (17) so that the red dot on the Lens' mounting end comes opposite the red dot on the Lens Mount (19) then turn the lens about 65° to the right (clockwise). It will lock itself with a click.

You can also use the Aperture/Distance Mark on the lens barrel as your guide because it is located on the same line as the red dot on the Lens' mounting end

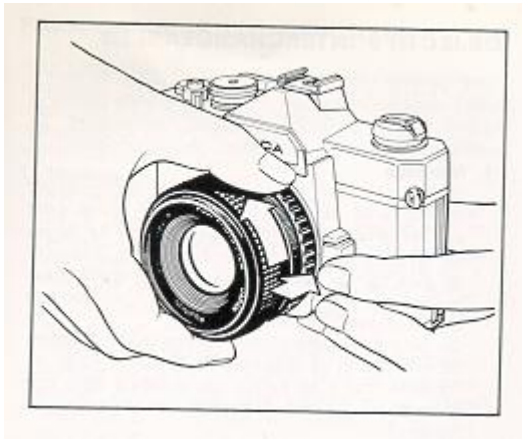

### 2. Dismounting

While pressing in the Lens Lock (23) toward the camera body, turn the lens to the left (counterclockwise) as far as it will go, then pull it out toward the front. \* When changing the lens, be careful not to touch the lens glass or the mirror in the body with your fingers.

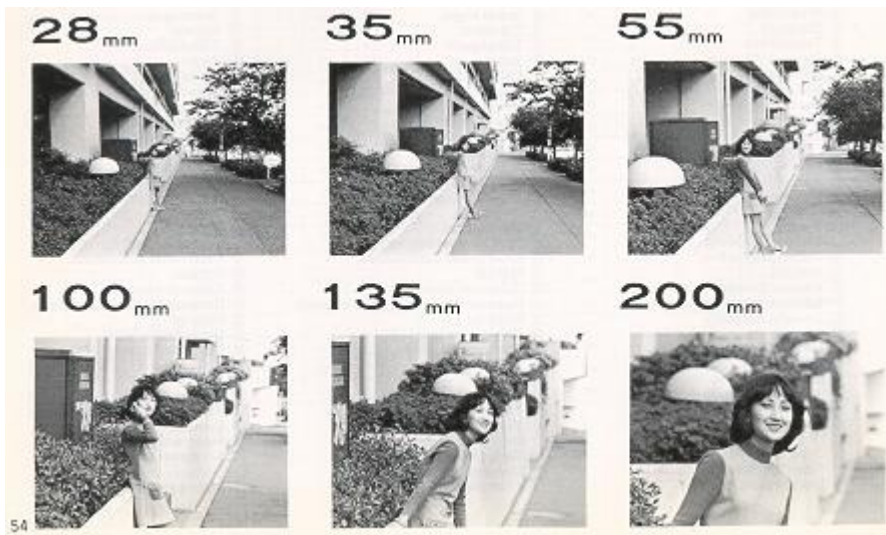

## COUPLING RANGE OF THE FUJICA STX-1n'S EXPOSURE METER

The ASA film speed and shutter speed are coupled over the range shown in the chart on the next page. To measure the exposure you can use the entire range of apertures provided on the lens you are using

**Example: With the ASA speed selector set to 100 you can use a shutter speed of from 1/2 to 1/700 sec. The aperture will automatically be coupled to the shutter speed being used**

ASA	Shutter speed that link with the meter
25	1/2 sec to 1/700
32	1/2 sec to 1/700
40	1/2 sec to 1/700
50	1/2 sec to 1/700
64	1/2 sec to 1/700
80	1/2 sec to 1/700
100	1/2 sec to 1/700
125	1/2 sec to 1/700
160	1/2 sec to 1/700
200	1/2 sec to 1/700
400	1/2 sec to 1/700
800	1/4 sec to 1/700
1600	1/8 sec to 1/700
3200	1/15 sec to 1/700

## EXPOSURE CORRECTION

Any normal subject can be accurately exposed by following the meter reading. However, best results are obtained under the following situations by correcting the exposure.

### 1. Back lighted Subjects, etc.

Back lighted subjects or ski scenes, which are dominated by white areas and strong reflections, will turn out with the main subject underexposed. By opening the aperture by 1/2 or 1 full stop. or by approaching the main subject to measure the light intensity, it can be correctly exposed

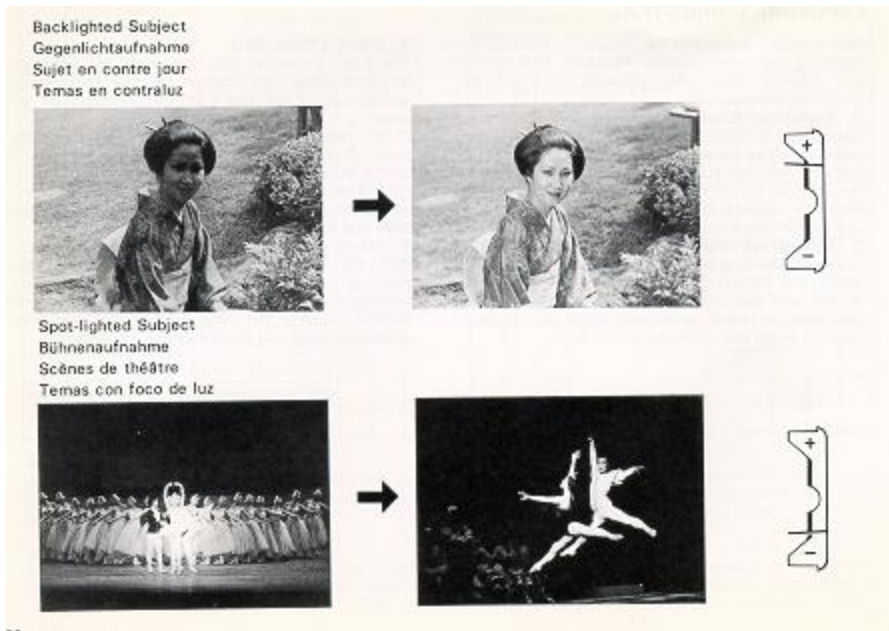

## 2. Spot-lighted Subjects. etc.

A person standing before a black background or a spot-lighted subject in a stage play will be influenced by the dark surroundings and turn out overexposed. The aperture should be stopped down by 1/2 or 1 full stop below that indicated by the meter.

## 3. Copying Documents

The major portion of most documents are occupied by white areas. The situation calls for opening the aperture by 1 full stop from that indicated by the meter.

If you want to be more precise. place an 18% standard reflectance card in front of the camera and set the exposure with the exposure meter

For maximum corner-to-corner sharpness. the minimum practical aperture should be used for copying work and for taking close-ups.

## 4. Taking Advantage of the Eye Cup

With the aperture stopped well down, the light reflected from your eye or spectacles (if you are wearing them) will reach the focusing glass and slightly influence the meter reading. To avoid this, use an Eye Cup over the Viewfinder eyepiece

## USING THE MOUNT ADAPTER X-S

If you want to use your Praktica screw-mount Fujinon lenses on the Fujica STX-1n use the Fujica Mount Adapter X-S (optional accessory).

(1) Screw the Mount Adapter X-S on the lens rear

(2) Place the red dot on the adapter s rear end against the red dot on the camera s Lens Mount (17) and turn the lens 65 to the right (clockwise). It will lock into position with a click.

(3) While looking through the viewfinder press in the Depth of Field Preview Button (11), hold it there and press the Shutter Release Button halfway down Then turn the Aperture Ring until the LCD in the viewfinder moves into the center of the indentation.

(4) Focus the lens. compose your picture and squeeze the Shutter Release Button gently down.

## UTILIZING THE LENS DEPTH OF FIELD

### 1. What is meant by Depth of Field

To check the effects of the aperture you have selected —how well you have blurred out the background or how wide the depth of sharpness is - all you have to do is to look through the viewfinder, because the aperture will close down to the size you have selected as you press In the Depth of Field Preview Button

Thus. the sharpness of a picture extends over a considerable range both in front of and behind the point the lens is focused on This zone of sharpness is referred to as the depth of field The width of the depth of field differs depending on the lens focal length, subject distance, and lens aperture

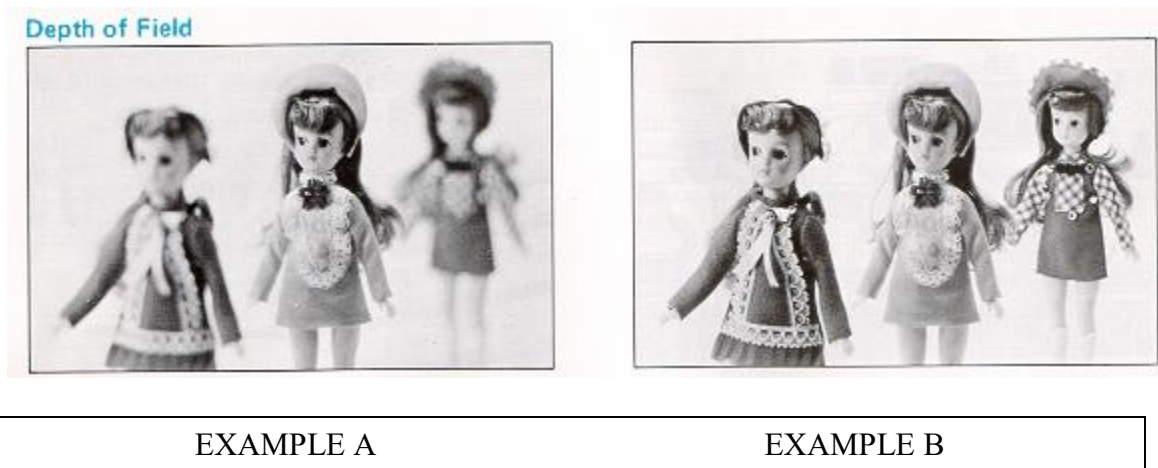

(1) The higher the aperture number (the smaller the aperture), the wider the depth of field The lower the aperture number, the narrower it becomes.

(2) The longer the focal length of the lens, the narrower the depth of field, and the shorter it is the wider it becomes.

(3) The farther the distance the lens is focused on, the wider the depth of held.

(4) The zone of sharpness in front of the point of sharpest focus is narrower than the zone of sharpness behind the same point.

(5) Example A shows the aperture fully open. Example B shows the aperture stopped down to f/16.

## 2. How to see the Depth of Field

All the interchangeable lenses of the FUJICA STX-1n are provided with a depth of field indicator on the lens barrel. For example, if you are using an F2 2 55 mm normal lens and have set the aperture at f/8 and the distance at 15 feet (5 m), everything from about 11.5 feet (3.5 m) to 28.5 feet (8.7 m) will be in sharp focus.

### USING THE SELF TIMER

If you are taking pictures of a group or if you are shooting a family souvenir picture and want to get into the picture yourself, just use the self-timer. First, mount the camera on a tripod, wind the film and push the Self-timer Set Lever all the way down, Next, press the Self-timer Start Button and move back into the picture. The shutter will be automatically released in 8 - 10 seconds.

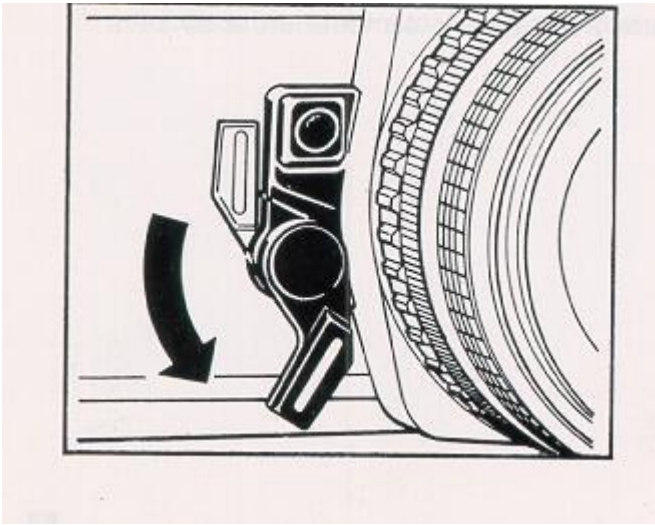

\* You can set the self-timer first, then wind the film afterwards, whichever way you prefer.

\* Don't press the Shutter Release Button "instead" of the Self-timer Start Button, because you will release the shutter if you do

\* Make sure the Self-timer Lever is pushed all the way down (never part-way down) before depressing the Start Button

### INFRARED PHOTOGRAPHY

To take infrared pictures with infrared film in your camera, the Lens is focused on a point slightly short of your subject. The procedure is as follows:

1. Focus the lens on your subject.

2. Check the distance given on the Distance Ring and move that distance opposite the Infrared Setting Mark. Next, put a red filter on the Lens and shoot. (The Infrared Setting Mark is the small red dot located next to the Lens Setting Mark. )

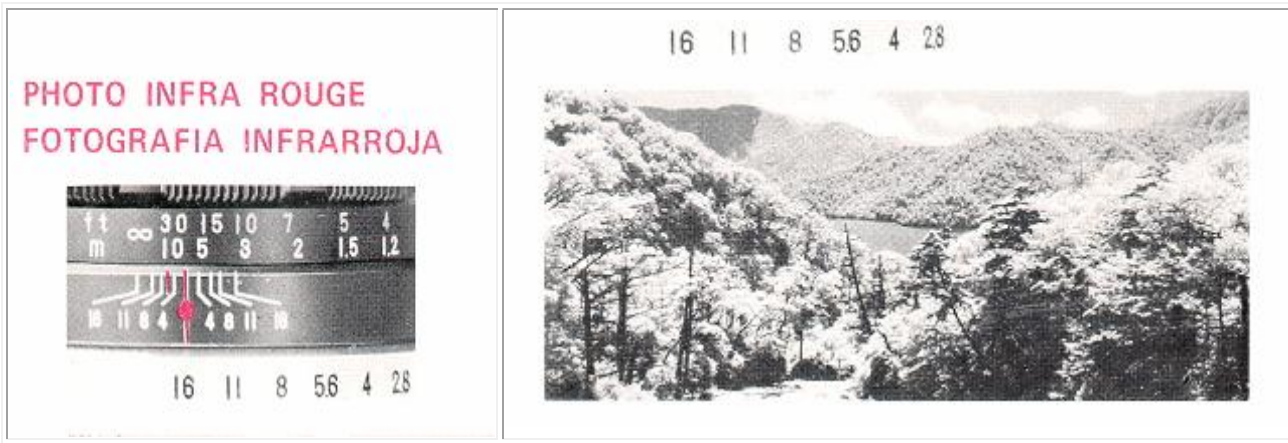

\* Read the instruction sheet packed with your infrared film carefully because exposure is not determined by subject brightness.

### TAKING FLASH PICTURES

You can use a flash for shooting indoors and night pictures as well as for supplementary lighting in outdoor photography To take flash pictures. use a cordless hot-shoe type electronic flash Just clip it Into the camera s Hot Shoe (13) and set the Shutter Speed Selector (18) to 1/60 sec (marked with a red X on the Shutter Speed Scale)

\* Setting the aperture

(1 ) If you are using an automatic electronic flash. set the Aperture Selector (18) to the specified aperture and the flash will take care of the rest

(2) If you are using an ordinary electronic flash. just divide the guide number of your flash by the distance from flash to subject to find the correct aperture



## ACCESSORIES FOR THE FUJICA STX-1n



- (1) Fujica STX-1n
- (2) Fujica Auto Strobe AZ
- (3) Fujica Auto Strobe 300X
- (4) Camera Case STX-1n
- (5) Gadget Bag L
- (6) Gadget Bag S
- (7) Fujica Slide Copier X
- (8) Fujica Auto Bellows X
- (9) Fujica Focusing Rail X
- (10) Fujica Macrocopy X
- (11) Fujica Microscope Adapter X
- (12) Fujica Teleconverter 2X
- (13) Fujica Auto Extension Tube X25
- (14) Fujica Auto Extension Tube X50
- (15) Fujica Right-Angle Finder
- (16) Fujica Eye Cup
- (17) Fujica Rubber Lens Hood
- (18) Fujica Mount Adapter X-S
- (19) Fujica Reverse Adapter X
- (20) Fujica Close-up Lens
- (21) Fujica Filter CROSS-4
- (22) Fujica Filter MULTI-5
- (23) Fujica Eyesight Adjustment Lens +2
- (24) Fujica Eyesight Adjustment Lens +0 5
- (25) Fujica Eyesight Adjustment Lens -2 5
- (26) Fujica Eyesight Adjustment Lens -4
- (27) Fujica Filter Skylight(1B)
- (28) Fujica Filter SO 56

- (29) Fujica Filter SR 60
- (30) Fujica Filter SY 48
- (31) Fujica Filter FL-W
- (32) Fujica Filter LBA-12
- (33) Fujica Filter LBB-12
- (34) Fujica Filter ND-4
- (35) Fujica Filter PL
- (36) Fujica Filter UV
- (37) X-FUJINON 1:2 2 f=55mm
- (38) EBC X-FUJINON 1: 1 2 f=50mm DM
- (39) X-FUJINON 1:1 6 f=50mm DM
- (40) 3EBC X-FUJINON 1:1 6 f=50mm DM
- (41) EBC X-FUJINON M 1:3 5 f=55mm DM
- (42) EBC X-FUJINON F 1: 2 8 f = 16mm DM
- (43) EBC X-FUJINON SW 1:3 5 f=19mm DM
- (44) EBC X-FUJINON W 1:2 8 f=24mm DM
- (45) EBC X-FUJINON W 1:3.5 f=28mm DM
- (46) EBC X-FUJINON W 1 :2 8 f=35mm DM
- (47) EBC X-FUJINON T 1 :4.5 f=200mm DM
- (48) EBC X-FUJINON T 1: 2 5 f = 135mm DM
- (49) EBC X-FUJINON T 1:3.5 f=135mm DM
- (50) EBC X-FUJINON T 1:2 8 f=100mm DM
- (51) EBC X-FUJINON Z 1:4 5 f=85 - 225mm DM
- (52) EBC X-FUJINON Z 1 :4 5 f=75 - 150mm DM
- (53) X-FUJINON Z 1:3 5 - 4 5 f=43 - 75mm DM
- (54) X-FUJINON Z 1:3 5 - 4 2 f=29 - 47mm DM
- (55) EBC X-FUJINON T 1 :4.5 f=400mm

## **ACCESSORIES FOR CLOSE-UPS AND COPYING**

The single-lens reflex camera is the ideal equipment for taking close-up pictures and for copying work. You are assured of simplicity and accuracy with the accessories provided for these purposes

### **\* Close-up Lens (20)**

If you are shooting a subject that is closer than the shortest shooting distance of the camera lens, just screw in the Close-up Lens in front of the taking lens. With a normal lens in place, it will let you shoot your subject from as close as 11 inches (28cm) up to 19 7 inches (50cm) ·

### **Extension Tube X (13) (14)**

This is used between the lens and camera body to extend the lens for taking extreme close-ups and copying. The new Fujica Auto Extension Tubes X25 and X50 are used separately and permit a magnification of about 0.5X and 1X with a normal lens. They are equipped for automatic aperture setting and full-aperture metering to allow you to set the exposure with the aperture wide open

### **\* Extension Bellows X (8)**

This unit will let you freely adjust the distance between lens and film plane. It is a prime accessory for taking close-ups and high magnification shots of small objects at close distances

**\* Reverse Adapter X (19)**

This accessory is used for mounting the reverse end of the lens to the Extension Bellows unit to simplify focusing when taking pictures of subjects 78 magnified to larger than life size.

**\* Microscope Adapter X (11)**

This is used in photomicrography for attaching the camera body to the microscope eyepiece

**\* Right Angle Finder (15)**

This is attached to the Viewfinder Eyepiece to simplify viewing through the finder when the camera is aimed from a low position or when it is mounted on a copying stand The eyesight adjustment lens is built in.

**\* Macrocinecopy X (10)**

This accessory is used for making film reproductions of 8 and 16mm films and microscope slides with the FUJICA STX-1n.

**EXPAND THE VERSATILITY OF YOUR FUJICA STX-1n WITH PROPER ACCESSORIES**

The FUJICA STX-1 is provided with a broad range of accessories that will help you to expand the capabilities of your camera.

**\* Lens Hood (17)**

This is a vital accessory because it prevents unwanted extraneous light from entering the lens. It is particularly useful for shooting back lighted subjects The Lens Hood is recommended for shooting under all conditions. If you are not shooting, you can turn it around and cover the lens with it. The lens cap is made to fit over the Lens Hood in this position.

**\* Eyesight Adjustment Lens (23) (24) (25) (26)**

Eyesight Adjustment Lenses are available to those who find it hard to focus the lens due to eyesight difficulties Four different attachment lenses (+2. +0 5 -2.5 and -4 dioptor) are available to the far-sighted or near-sighted

**\* Eye Cup (16)**

This is a protection against extraneous light for a clearer view through the Viewfinder. It also prevents light from entering the camera through the Viewfinder Eyepiece.

**\* Lens Cap**

Lens Front Cap Protects the lens front glass.

Lens Rear Cap Protects the rear glass and automatic diaphragm of the dismantled lens.

Body Mount Cap Protects the interior of the camera body from dust after the lens has been dismantled.

## FUJICA FILTERS (12 types)

Filter	Film type	Uses
SKYLIGHT (1B)	Black and white, color	Reduces the blue-greenishness in landscape pictures Used also for lens protection
UV	Black and white, color	Ultraviolet absorbing filter Used also for lens protection.
SY48	Black and white Black and white	Yellow filter. For landscapes
S056	Black and white	Orange filter. For pictures of mountains and distant landscapes
SR60	Black and white	Red filter For strong contrast and infrared pictures.
ND-4X	Black and white, color	Gray filter. For reducing the light intensity
LBA-12	Color	Color conversion filter for tungsten film
LBB-12	Color	Color conversion filter for daylight film
FL-W	Color	Light balancing filter for shooting in fluorescent light
PL	Black and white, color	Removal of reflections
CROSS-4	Black and white, color	For special effects. Contains a cross screen
MULTI-5	Black and white, color	For special effects Yields multiple images (5) on the same frame

## CARE AND STORAGE OF YOUR FUJICA STX-1n

After removing the exposed film from the camera, press the shutter release button to be certain the shutter is released

Dust off the camera periodically and wipe it clean with cleaning cloth (example Silicon cloth) Use a blower brush to clean dust and film fragments that may have accumulated inside the camera.

Guard the lens and viewfinder eyepiece against finger marks and dust Use a blower brush to remove dust. Wipe off finger marks gently with lens cleaning fluid and lens cleaning paper. Do not touch the mirror with your fingers. \* If you are not using the camera for a long interval, remove the batteries. place the camera and batteries in separate cases. and store them away from moisture, heat. and dust All the better if you can get hold of some desiccant or similar drying agent to put into the cases together with the camera and batteries