

Minox B

Posted 12-27-'02

This camera manual library is for reference
and historical purposes, all rights reserved.

This page is copyright© by mike@butkus.org, M. Butkus, NJ.

This page may not be sold or distributed without
the expressed permission of the producer
I have no connection with any camera company

On-line camera manual library

If you find this manual useful, how about a donation of \$3 to:

**M. Butkus, 29 Lake Ave., High Bridge, NJ 08829-1701
and send your e-mail address so I can thank you.**

**Most other places would charge you \$7.50 for a electronic copy
or \$18.00 for a hard to read Xerox copy.**

**This will help me to continue to host this site,
buy new manuals, and pay their shipping costs.**

It'll make you feel better, won't it?

If you use Pay Pal, use the link below.

Use the above address for a check, M.O. or cash.



www.PayPal.me/butkus

Venmo @mike-butkus-camera

[Back to main camera manual page](#)

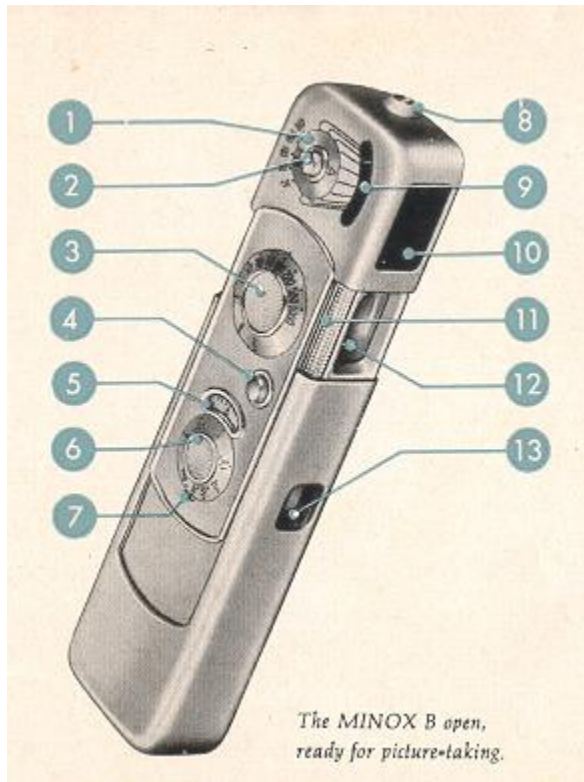
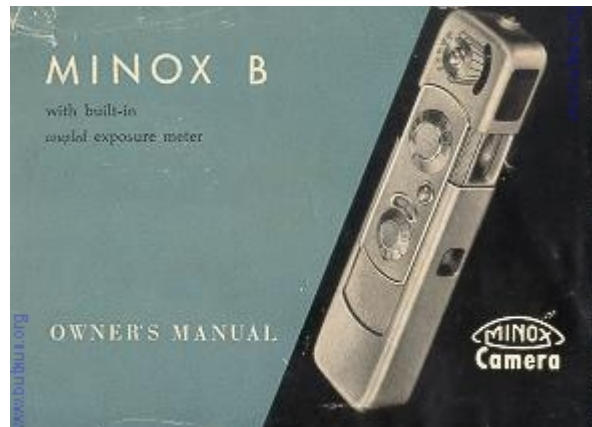

1. Exposure Meter Disc
2. Exposure Meter Button
3. Shutter Speed Dial
4. Shutter Release Button
5. Exposure Counter
6. Distance Scale
7. Depth of Field Bracket
8. Flash Plug
9. Exposure Meter Indicator Window
10. Exposure Meter Window
11. Filter Slide
12. Viewfinder (Front Window)
13. Lens Window

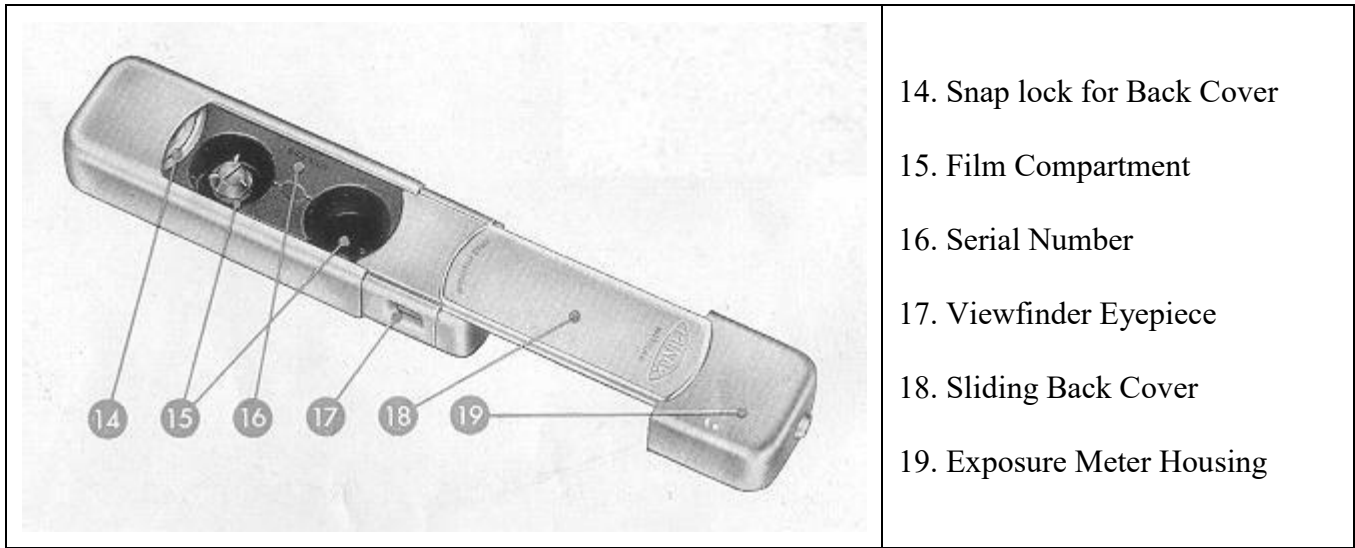

- 14. Snap lock for Back Cover
- 15. Film Compartment
- 16. Serial Number
- 17. Viewfinder Eyepiece
- 18. Sliding Back Cover
- 19. Exposure Meter Housing

CONTENTS

(Set also alphabetical index on page 48)

How to use the MINOXPage

Opening the camera * Telescopic Rapid Wind * Holding the MINOX * Distance setting * Zone of sharpness *
 Setting the shutter * Built-in exposure meter * MINOX always works at f/3.5 * Viewfinder Exposure counter *
 Loading ASA film speeds * Un-loading * Filters * Measuring chain * Take care of your MINOX2

Tips for best results

The "best" film * Correct exposure measurement * Steady * Longer exposures Frame your subject * Close-ups
 of small things * How to stop moving subjects Flash is easy * It's a colorful world * Copying Changing the film
 type ... 28

What happened? 40

The MINOX Camera Clamp44

The MINOX Pocket Tripod 44

The MINOX Slide Projector 45

The MINOX Enlarger 45

Other MINOX Accessories46 - 47

Subject size and depth of field tables

Distance Focused On	Subject / Field Size – inch.	Depth of Field
∞ Infinity	–	12' 8" to ∞
12'	105 x 77	6' 1 1/2" to ∞
6'	53 x 38	4' to 11' 4"
4'	35 x 25 1/2	3' 1/2" to 5' 11"
3'	26 x 19	2' 5 7/8" to 3' 9 1/2"
2' 4 7/8"	20 3/4 x 15	1' 11 7/8" to 2' 11 1/4"
2'	17 1/8 x 12 1/2	1' 8 3/4" to 2' 4 1/2"
1' 8 3/4"	14 7/8 x 10 7/8	1' 6 3/8" to 2'
1' 6"	12 3/4 x 9 3/4	1' 4 1/8" to 1' 8 1/2"
1' 2 3/8"	10 1/2 x 7 1/8	1' 1 1/8" to 1' 3 7/8"
1'	8 7/8 x 6	11 1/8" to 1' 1"
10 7/8"	7 1/2 x 5 3/8	10 1/8" to 11 3/4"
10"	6 3/4 x 4 7/8	9 1/4" to 10 3/4"
8 7/8"	6 x 4 3/8	8 3/8" to 9 1/2"
8"	5 3/8 x 3 7/8	7 5/8" to 8 1/2"

Congratulations--with your MINOX B you are embarking on a new, un-burdened kind of picture taking: Your MINOX B is not only exceptionally small, precise and modern, it is also far easier to use than almost any other camera. It will give you lots of pleasure!

It's easy to get fine pictures with the MINOX B but, naturally, the more you know about the camera, the better, more certain, will be the results. This little book wants to show you the way.

Read the various sections carefully--it's time well spent, and will pay off generously in fine MINOX pictures!

The **first section** explains the best way to hold the MINOX, how to load it and unload it, how to set it.

Part two will help you select the proper kind of film for best results, and tells about color photography, flash, filters, close-ups, and about some special uses for your MINOX.

The **final pages** come in handy if something goes wrong; there you will find the cause - usually a minor mistake which may occur if you have not read the first two sections carefully! And it's so easy to avoid such mistakes.

But NOW--why not get acquainted with the ease of MINOX photography?

HERE'S HOW

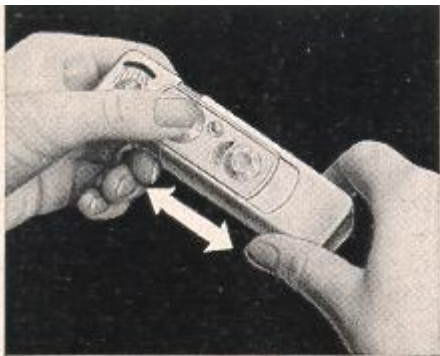

You are, naturally, anxious to put the first film into your MINOX and to start shooting pictures. Please hold on for little while, and get to know the most important features of the camera while it is still unloaded.

You'll be much more confident and sure of success when you know more about the "HOW".

Opening the camera

The camera is closed when you take it out of its leather case. To open it for picture taking, grasp it with both hands as shown here, and pull it open as far as it will go. This brings out the viewfinder and lens window, and makes the MINOX ready for shooting.

Telescopic rapid wind



After you have taken a picture, 'close' the camera. Then, for the next picture, you pull it open again. That's the secret of the telescopic rapid winding mechanism of the MINOX: Each time the camera is closed and re-opened, the film is advanced for the next picture, the shutter is re-wound, and the exposure counter moves to the next number, all automatically!

In a hurry? ONE-TWO-your MINOX is ready for the next picture. But it's important to close and open all the way every time!

The small circle in the lens window indicates that the shutter is wound ready for the next picture. The circle disappears after you have released the shutter. That's your signal that you must 'push-pull' **before you take the next picture**. Clear and simple, isn't it?

Hold it steady

A steady and firm hold is the best assurance for good pictures with your MINOX. If the camera moves while you are taking a picture, you are bound to get blurred results. Hold the camera firmly, yet relaxed, with your hands steadied against the face. Keep both thumbs under the camera, other fingers on top or at the side so that the lens and exposure meter window are unobstructed. The illustrations on this and the next page show the most practical way of holding your MINOX; it's a firm and steady hold, and nothing covers the lens, viewfinder, or exposure meter window.

It's a good idea to practice this hold in front of a mirror to check yourself. You'll notice that the same hold is used for horizontal and vertical pictures.





Taking the picture

Now that you know the proper hold, look into the viewfinder and frame your picture in the luminous rectangle; when you're all set, squeeze the shutter release button gently. A little counter-pressure from the thumb underneath the camera helps to keep the MINOX steady. The shutter operates so smoothly and quietly--the picture is taken without effort!

The MINOX B requires a minimum of operating steps: Setting distance and exposure is all that's needed--and easy, too.

Above: Correct hold for horizontal pictures

Right: Similar hold for vertical pictures.

Distance setting



There are two engraved discs on the control panel of your MINOX; the smaller one is the distance scale. It is calibrated from infinity (∞) to 8 inches, with additional markings 6: 3, 2, 1 1/2, 1 ft., and 10 inches. A red dot indicates 12 ft., and also serves as a general "snapshot" setting.



<Setting the distance scale. Arrow points to sharpness zone bracket >

To set a given camera-to-subject distance, rotate the distance dial with your finger on the knurled centre until the desired distance number is at the black dot of the 'sharpness zone' bracket.

This little bracket is more important than the black dot in its centre:

Let's say you are taking pictures at a picnic, with the distance setting at 12 feet that's (that's the red dot between ∞ and 6'). The campfire is 12 feet away, some of the guests are sitting at a table 8 feet from the camera, while one of the youngsters is just bringing an extra log and is now 15 feet away from you. You'll get them all perfectly sharp in your MINOX picture, because it gives you a sharpness 'bonus' in front and beyond the focused distance. The zone of sharpness from nearest to farthest distance is also called "depth-of-field". The bracket along the distance scale tells you the extent of the zone of sharpness for every distance setting.

For most of your pictures, you don't have to set the distance critically. It is sufficient if the main object of your picture is within the zone of sharpness. The MINOX has exceptionally great depth of field and makes focusing very simple.

<p>Snapshot Setting: Zone of sharpness 6 ft to Infinity Greatest sharpness at 12 feet.</p> 	<p>You get the greatest zone of sharpness with the red dot (Snapshot Setting); from 6 feet to infinity (a). This is your ideal choice for all pictures which require quick readiness, fast shooting. You can shoot groups, games, travel pictures, races -- whatever comes before your camera--as long as the main point of interest is at least 6 feet from the camera.</p>
<p>Zone of sharpness 4 ft to 11 ft. Greatest sharpness at 6 ft.</p> 	<p>This snapshot setting (see illustration at top will take care of most of your pictures.</p>
<p>Zone of sharpness 3 ft. to 6 ft. Greatest sharpness at 4 ft.</p> 	<p>Use the snapshot setting for scenery only if an important part of the foreground is closer than 12 ft. Otherwise, always use the infinity (∞) setting for landscape pictures (sharpness reaches from 12 ft. to infinity).</p>

Two other settings with zones of sharpness from 4 ft. to 11 ft., and from 3 ft. to 6 ft., respectively, are shown in the illustrations on the previous page. Complete tables showing the depth of field ranges and subject sizes at various distance settings are shown on page 51. (inside back cover).

As you can see, the zone of sharpness gets smaller at closer distances, and at very close distances it amounts to inches and less. Therefore, close distances must be set carefully on the distance scale, but that is easy because the safety chain of your MINOX has small beads for distances corresponding exactly with the close distance settings engraved on the distance scale. With the chain locked in the camera so that it is held taut and at right angles from the camera to the subject, the beads are placed at 8, 10, 12, and 18 inches; the full length of the chain is 24 inches.

To sum up:

You need not set distances beyond 3 feet too critically - make the "sharpness zone" bracket do the work for you.

Set the distance scale so that the important part of the picture is safely within the sharpness zone.

For extreme close-ups always use the measuring chain.

The shutter

	<p>To produce a well defined, correctly exposed picture, the film must absorb a definite amount of light. The less light comes from the picture area, the longer this light must act on the film -- the shutter must stay open for a longer time. Very bright scenes require only a short shutter speed. This length of "exposure" is regulated with the larger dial on the control panel of your MINOX. You can set the shutter while the camera is still closed, or after it has been opened, whether the shutter is wound nor not.</p>
--	---

To set the shutter speed, place the thumb on the knurled centre of the shutter speed dial while holding the forefinger under the camera and, with the other hand, turn the camera. (See illustration). It's really very easy. The engraved figures represent fractions of a second: 2 indicates 1/2 second, 1000 is 1/1000 second, etc.

But, don't let these figures worry you--you need not even look at them! Yours is a MINOX B--the built-in coupled exposure meter does the thinking for you. (See page 29 for some helpful hints on exposure measurement!)

The built-in coupled exposure meter

The coupled exposure meter distinguishes the MINOX B from the MINOX A camera. You need not estimate shutter speeds, you don't even have to refer to a table or scale, and then transfer shutter speeds from 1/2 to 1/1000 second to the shutter speed dial. The exposure meter is coupled with the shutter speed dial. You simply match a pointer with an indicator needle --that's all: You have already set the correct shutter speed! Only once--when you put the first film into the camera --do you set the exposure meter for the 'speed' of the film, and couple it with the shutter. (see page 20). You need never touch the meter setting again until you use film of a different speed.

Using the exposure meter is child's play:

Before you take a picture, look at the scene through the viewfinder - just be careful not to cover the front window of the meter with your finger - and hold down the meter button with the forefinger or third finger of your left hand. After two or three seconds, let the button go and take the camera from your eye.

		
<p><i>Look at the scene through the viewfinder; hold down the meter button for two or three seconds: release the button and take camera from your eye.</i></p> <p><i>Turn shutter speed dial until open triangle (upper left arrow) points to indicator needle (upper right arrow) along connecting line. This sets exposure automatically</i></p> <p><i>You are now ready to take the picture. Hold camera correctly! (see page 4).</i></p>		
<p><i>Look at the scene through the viewfinder; hold down the meter button for two or three seconds: release the button and take the camera from your eye</i></p>	<p>Turn shutter speed dial until open triangle (upper left arrow) points to indicator needle (upper right arrow) along connection line. This sets exposure automatically</p>	<p>You are are now ready to take the picture. Hold the camera correctly!</p>

At one end of the camera you will see the curved indicator window of the exposure meter, and next to it--surrounding the meter button--a flat disc with an open triangle mark and a green dot. The rotating disc and indicator window are connected by thin black lines. When you turn the shutter speed dial, the meter disc with the triangle mark also turns: both are coupled. Now turn the shutter speed dial until the open triangle is set to the black line that connects with the indicator needle. If the needle is between two lines, set the open triangle between the two lines also.

By thus pointing the open triangle to the line leading to the indicator needle, you have automatically set the correct shutter speed. If the shutter speed dial happens to be set between engraved numbers, don't worry: The shutter speed scale of the MINOX B is matched with the exposure meter, providing an infinite range of speeds between 1/2 and 1/000 second.

If you are using the green filter with black and white film (see page 24), turn the green dot - instead of the open triangle - to the indicator needle. This setting automatically compensates for the exposure difference required by the green filter.

The second measuring range

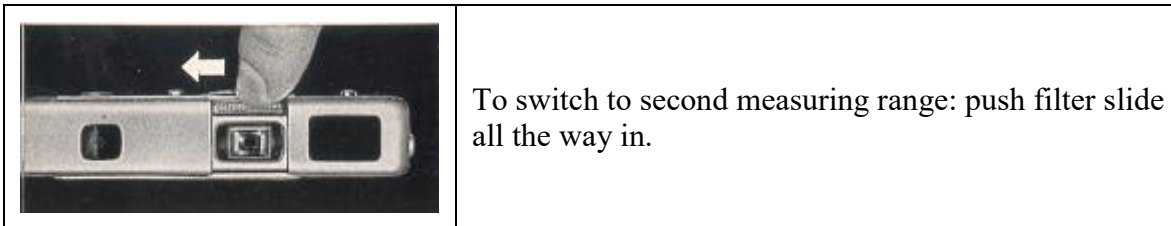
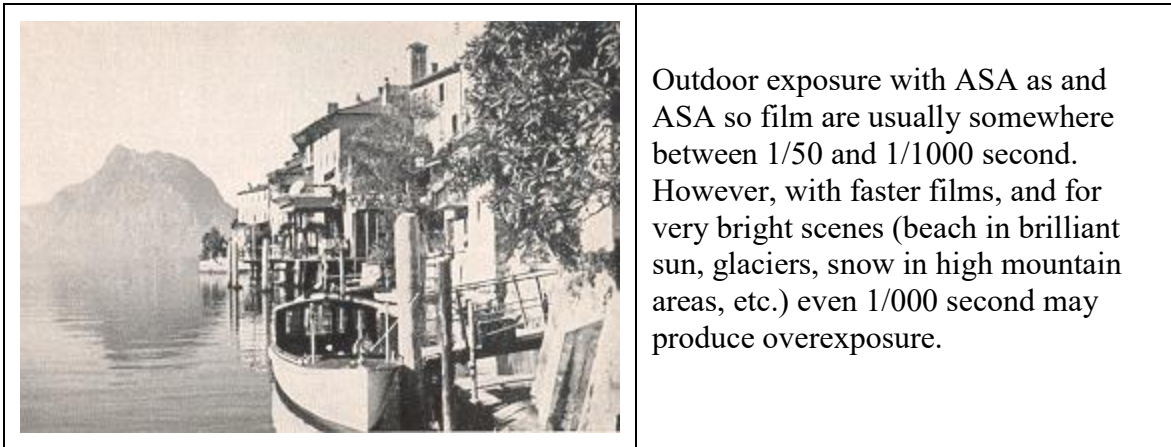

The shutter speed dial cannot be turned past the '1000' mark to line up the meter disc with indicator needle. Therefore, a second measuring range has been provided.

If you cannot line up the open triangle with the indicator needle, push the filter slide above the viewfinder window all the way in (see illustration). This puts a neutral density (grey) filter in front of the lens, and switches the exposure meter automatically to compensate for the exposure difference imposed by the filter.

After this "switch", proceed as usual: Look at the scene through the viewfinder - hold down the meter button two or three seconds - turn open triangle to indicator needle. The neutral density filter now puts the exposure into the normal speed scale.

Whenever the resulting shutter speed is slower than 1/50 second (1/20, 1/10, etc.), remember to brace your hands with the camera against a wall, tree, or other firm support. Otherwise a blurred picture may result. Of course, the MINOX Tripod (page 44) is ideal for this purpose; in fact, it is indispensable for longer (B and T) exposures.

B and T exposures

In addition to speeds of 1/2 to 1/1000 second, the shutter speed dial has the letters B and T engraved. What do they mean?

B: The shutter opens when the shutter release button is pressed down and closes again when you let the button go;

T: The shutter opens when the shutter release button is pressed down and stays open until the button is pressed a second time.

Both settings are designed for longer exposures: 'B' for exposures from one to several seconds, 'T' for still longer exposures. For such extended exposure, the MINOX must be placed on a solid support, or mounted on a tripod with the camera clamp (page44), and released with a cable release. The MINOX Tripod (page44) comes already equipped with a cable release.

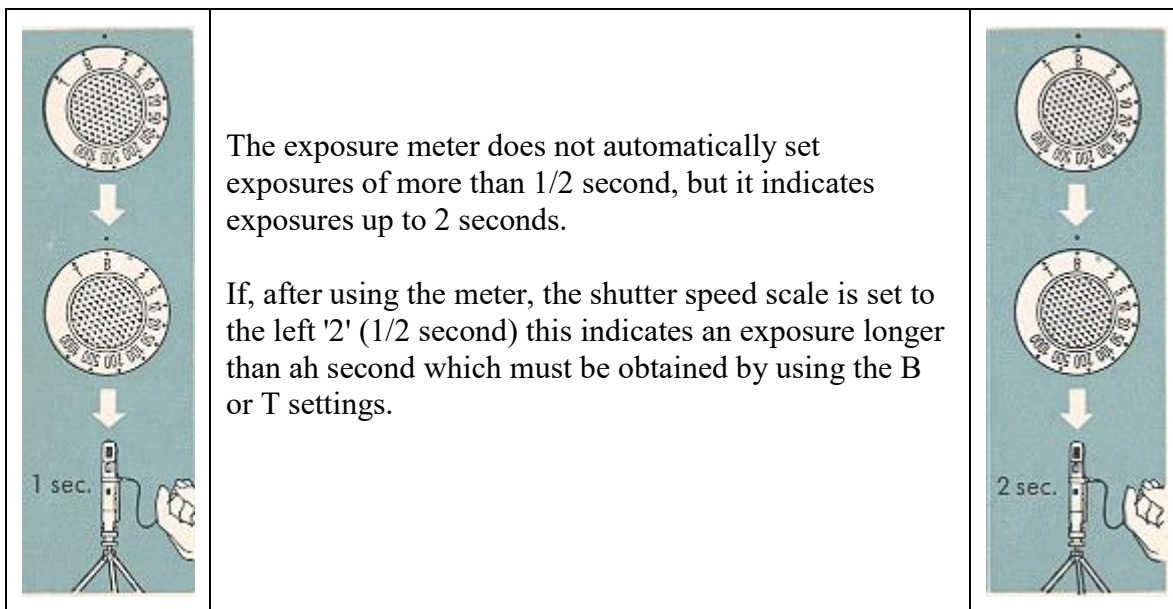

If the shutter speed dial points to the blue dot between '2' and B (see illustration at left), the indicated exposure is 1 second; if the dial points to B, the indicated exposure is 2 seconds. (see illustration at right). Exposures indicated by intermediate positions can be estimated. After you have determined these longer exposures, turn the shutter speed dial to B or T and hold the shutter open for the required time.

The illustrations show: top -- positions of speed dial after setting meter triangle mark to indicator needle; middle - setting of dial for making the exposure; bottom - a reminder to use a tripod or other firm support.

Flash Pictures

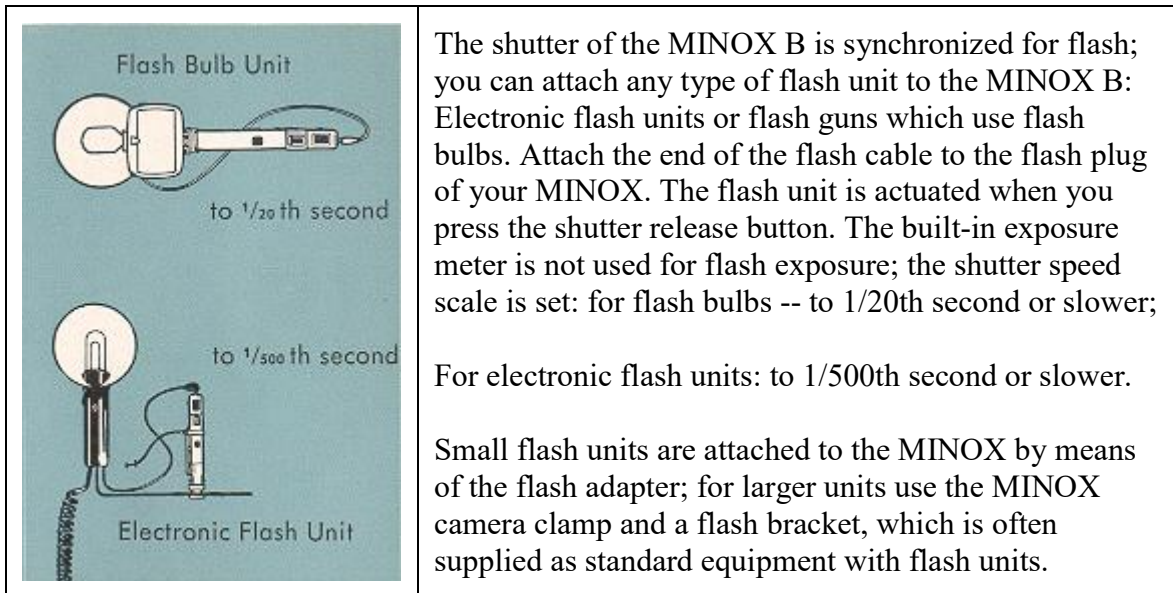

The shutter of the MINOX B is synchronized for flash; you can attach any type of flash unit to the MINOX B: Electronic flash units or flash guns which use flash bulbs. Attach the end of the flash cable to the flash plug of your MINOX. The flash unit is actuated when you press the shutter release button. The built-in exposure meter is not used for flash exposure; the shutter speed scale is set: for flash bulbs -- to 1/20th second or slower;

For electronic flash units: to 1/500th second or slower.

Small flash units are attached to the MINOX by means of the flash adapter; for larger units use the MINOX camera clamp and a flash bracket, which is often supplied as standard equipment with flash units.

For more complete information on flash light photography, see page 34.

To sum up:

The MINOX B has a built-in exposure meter coupled to the shutter speed dial which regulates shutter speeds from 1/2 to 1/1000 second; you simply point a triangle mark to the indicator needle of the exposure meter.

When the scene is so bright that even 1/1000 second would produce over-exposure, slide the neutral density filter in front of the lens. The exposure meter switches automatically to its second measuring range. Shutter speeds fall within the normal speed range. Exposures of more than 1/2, second are not automatically set on the shutter speed dial. However, the position of the shutter speed dial after 'matching' the indicator needle indicates up to 2 seconds exposure which must be obtained by using the B or T setting.

No F-stop setting - an important MINOX advantage

If you are an advanced amateur photographer, you may wonder why there has not yet been any mention of f-stops. It's simply because the MINOX has no f-stops! The 15mm Complan lens of your MINOX yields such extreme depth of field and, together with the slightly spherical curved design of the film gate, gives such outstanding definition over the entire film area that an adjustable lens diaphragm could be omitted --saving you an extra operation necessary with other cameras. That's another reason why the MINOX is so easy to use!

The MINOX always works at full f/3.5 lens opening.

The viewfinder

The luminous white frame within the large MINOX viewfinder shows you the exact picture area that will appear on the film. The viewfinder image is automatically corrected, at all distances, to agree with the film image. (Parallax Compensation). For extreme close-ups (8 -10 inches), the picture area lies a frame-width within the luminous frame.

The viewfinder eyepiece is so large that even spectacle wearers can observe the full viewfinder area; furthermore, they may use the MINOX viewfinder without special correction lens.

The exposure counter



The curved window next to the distance scale tells you how many exposures you have already made on a film. Before you insert a fresh film, the exposure counter must be set at the red dot between 50 and 0 (see illustration).

If you have just finished a complete 50-exposure film, the counter will already be at this setting. However, if you finished a 36-exposure film, or if the counter is at any other setting, you must set the counter by repeating a 1/4-inch 'push-pull' of the camera until it is set at the red dot.

Loading with film

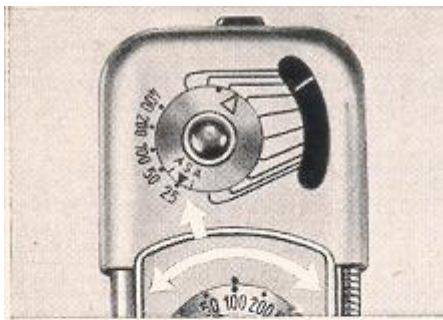

Film cassettes should be shielded from bright sunlight. Always load - or un-load - the MINOX in subdued light, or in the shade. (If there is no other shade within reach, turn your back towards the sun!)

The built-in exposure meter must be set to the speed of the film when you load your first film into the camera, and if you change to a film of different speed. The necessary steps are printed in blue on these pages.

If, after completing the first film, you again use film of the same speed, you can ignore the instructions printed in blue. Just make sure that the shutter speed dial is not turned while you are changing films.

Set exposure counter at red dot (see previous page).



Set the exposure meter - while the camera is still closed - by turning the camera shutter speed dial until the ASA film speed pointer (solid triangles) of the meter disc points to the ASA number of the film to be used: 25-50- 100, etc. (See page 22 for intermediate ASA numbers).

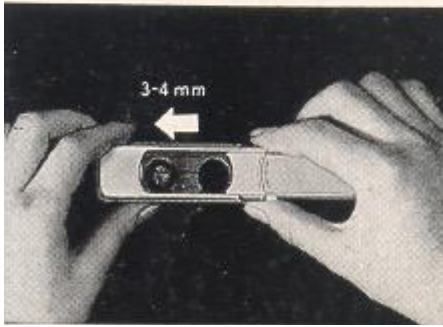

Pull the camera 'out'. Press town on crescent-shaped snap lock (white arrow in illustration 2) ant slide open the back cover until both film compartment are free.

Turn camera shutter speed dial to '100' which is marked with a red dot. (Illustration 3).

"Close" the camera about 1/8 inch to spread the film gate open; this occurs when the snap lock almost disappears in the camera (illustration 4). You can feel a definite resistance and see the gate open.

The film can be inserter--and taken out-- ONLY with an open film gate!



Drop the cassette into the film compartments. (see illustration 5). (There is only ONE way to insert the cassette--you can't make a mistake!)



Close the back cover until it snaps shut, and push the camera closed. 'Pull-push' camera once to advance the exposed film frame into take-up end of cassette. (illustration 6). If the back cover cannot be closed--this is a rare occurrence when the film take-up core is resting on the teeth of the transport wheel in the film compartment -- lift out the cassette, pull the camera open all the way, and close again until the film gate opens. This advances the film transport wheel. Re-insert the cassette, and proceed as described on page 21.

Intermediate ASA film speeds can also be set on the exposure meter by using the short lines on either side of the solid ASA triangle. as follows:

Engraved numbers: 25 50 100 200 400

LEFT LINE set on engraved number gives correct reading for: 16 32 64 125 250

RIGHT LINE set on engraved number gives correct reading for: 40 80 160 320 640

(Example: To set meter for ASA 32 -- set LEFT LINE on '50').

Un-loading

Watch the exposure counter--so is the last exposures Push-and-pull the camera twice. The exposure counter should now be at the red dot. Now open the back cover and spread the film gate open (as if to load). See page 21.

The film cassette will drop out the camera with slight tapping, or it may be lifted out by its bridge. Store the cassette in a film box, or wrap it in black paper until it is developed.

If the next film has a different ASA number, set the exposure meter for the new ASA number before opening the camera to remove the previous film. This saves you another step later on. (See page 20 about setting the meter).

* Some films have only 36 exposures -- see film package. After the 36th exposure, push-pull twice until film counter is at the red line between 37 and 38; then remove cassette. Advance exposure counter to the red dot between 50 and 0 before inserting a new cassette.

CAUTION: Do not advance films beyond the numbers indicated above, as the film end may be pulled completely into the take-up side; this may result in light entering through the cassette slit during un-loading.

To sum up:

Exposure counter must be at the red dot before a new film is inserted. Film gate must be open when film is inserted or taken out. The exposure meter is properly coupled with the shutter speed dial, if the black triangle of the meter disc points to the correct ASA number when the camera shutter speed dial it is '100'.

What film is in the camera?

If you have forgotten the speed of the film you have in the camera--simply turn the camera shutter speed dial to '100' and read the position of the solid black triangle on the meter disc!

Built-in filter

The MINOX B has two built-in filters which can be placed before the lens by means of the filter slide: a grey (neutral density) filter, and a green filter.

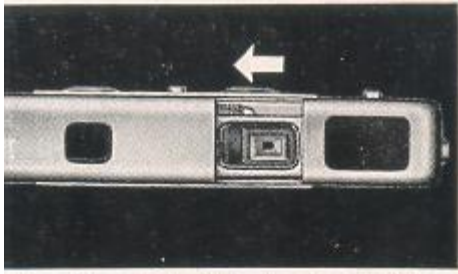

Filter slide pushed all the way in; grey filter in place, second measuring range switched on.

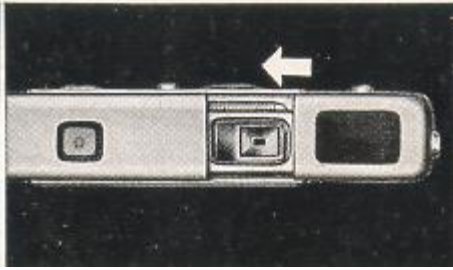

Filter slide pushed half-way in:
green filter in place.

Both filters have basically different tasks. The grey filter cuts down the light when even 1/1000 second would produce over-exposure in brilliant sunshine with fast film. With the grey filter before the lens, the exposure meter is automatically switched to its second measuring range. You may use the grey filter with black-and-white or color film.

The green filter, on the other hand, is intended to improve the tonal reproduction of natural colors in **black and white** pictures -- regardless of light conditions. You will find it particularly helpful in sunny landscapes: Green foliage, lawns, meadows, etc. will show better modulation in the print, the sky will be slightly darkened so that clouds stand out better. But, don't use the green filter with color film; it will turn the whole scene green!

The green filter absorbs some light and calls for slightly longer than normal exposure: Simply turn the green dot of the meter disc (instead of the open triangle) to the meter indicator needle; that takes care of correcting the exposure when you use the green filter.

Make sure that the filter you use fills the lens window completely.

Remember to push back the filter slide after use, if you want to take the next picture without a filter!

To sum up:

The grey filter prolongs exposure if the normal shutter speed range is insufficient. You may use it with black-and-white or color films.

The green filter is used with black and white film for better landscape and cloud pictures. It must not be used with color film.

Attaching the measuring chain

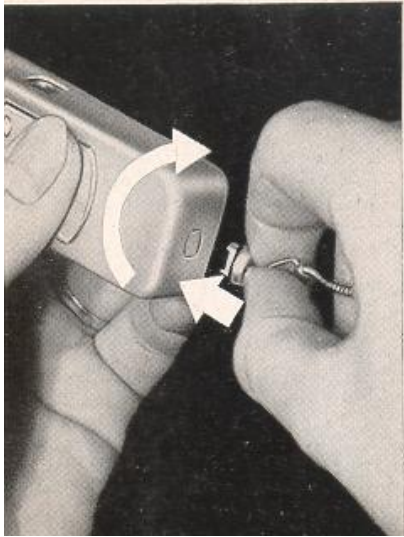

To protect your MINOX against accidental falls, always keep it on its chain. Insert the rectangular plug at the end of the chain into the corresponding chain socket of the camera. The spring-loaded dust cover will recede into the camera. Use the D-ring at the end of the chain in the manner of a screwdriver, inserting it into the slot of the plug disc, turn the plug one-quarter turn to the right. (See illustration). To detach the chain, reverse these steps; insert D-ring in the slot, turn one quarter **to the left**--the plug will jump out of the socket.

It pays to take care of your MINOX!



The optical glass window of the lens should always be spotless; finger marks and dirt impair the sharpness and brilliance of your pictures. From time to time- wipe the window gently with a soft linen cloth wrapped around a small wooden stick or tooth pick.

Keep the film compartments free from dust which may scratch the film; before inserting a fresh film cassette, blow into the compartment to dislodge and remove small dust particles.

Beware of sand and salt water! Only a few drops of salt water suffice to corrode the delicate mechanism of the camera. Should it ever drop into the water, you may perhaps save the camera if you open it and rinse it immediately after the salt water has entered, under running warm fresh water; then dry it at once near a heater or an open fire. Rush your MINOX to our Repair Department with the notation: SALT WATER DAMAGE. If sand gets into the camera, try to blow it out before you operate the 'push-pull' rapid wind, if there is the least "grating", STOP, leave the camera as it is and send it to for cleaning with the notation: CAUTION, SAND IN CAMERA!

Your MINOX was carefully tested and checked before leaving the factory, and provided with long life lubricants. Do not attempt to disassemble it, and, above all, do not lubricate any part of it.

The facilities of our Service Department are at your disposal if the camera should ever require adjustment or repairs.

TIPS FOR BEST RESULTS

The "best" film

MINOX films are available in several different types for black-and-white photography, and for color pictures. The black-and-white films vary in sensitivity (speed) and grain characteristics. The sensitivity is expressed in American Standard Association exposure index numbers: ASA 25, ASA 80, ASA 100 and ASA 200, etc. These numbers are stated on the film package and should be used in setting the exposure meter. (See page 20). ASA 200 film is twice as sensitive to light as ASA 100, ASA 100 twice as sensitive as ASA 50, and so on. Thus, under any given conditions. ASA 80 film, for instance, would require only half the shutter speed needed for ASA 28.

The lower the film sensitivity, the finer the detail it is capable of reproducing in the final print. Therefore, the fast films--ASA 100 and ASA 200--should be used only when there is not enough illumination for slower films, or when flash exposures are not feasible (stage photography, candid shots, etc.)

For 90% of your pictures, you will find ASA 25 the ideal choice; it has ultra-fine grain and thus gives you clear, sharp, crisp pictures; it has ample speed for all outdoor pictures and for flash shots. For copying of books, documents, etc. a special fine-grain film ASA 5 is available. (See page 38).

ASA 200 film and Color film is supplied in 36-exposure cassettes; all other black-and white films are in 50-exposure cassettes. For information about color film, see page 36.

Correct exposure measurement

You will always get correct exposures with your MINOX B Automatic camera, if you observe a few basic rules. The front window (cell) of the meter must be completely unobstructed to give a correct reading. Don't let a finger cover the window--check the correct camera hold on page 4 and 5.

Give the meter 2 to 3 seconds to measure the light while you hold down the button. Letting the button go too quickly may cause the needle to lock before it has reached full reading.

Always measure the important part of a scene. In a landscape, for instance, the sky which is usually much brighter than the principal parts of the scene, should not be included in the viewfinder while you are holding down the meter button. Point the viewfinder downward until most of the sky is no longer visible. Thus, you will get a correct reading for the fields, trees, houses, etc. which are important for the picture. Of course, when you take the picture, you may include the sky.

Similarly, when you take snapshots of people in the snow or in front of a light-colored wall, remember that the people are important, not the background. To get correct exposure, approach with your camera until you see in the viewfinder only the person or group which you want to snap. Only then should you press down the meter button to get your reading. After you have thus determined correct exposure, you may step back to include the background in the actual picture.

If it is inconvenient to make such a close-up measurement, you can use the "substitution" method of measuring the brightness of your hand or some object that is similar to, and receives the same light, as the actual subject of your picture.

Close-up measurement is also used in back-lighted (against-the-light) shots. Measure only the important subjects which are actually in the shade. Where this is impractical -- mountain scenery, for instance -- use this rule of thumb: Take the reading by pointing the camera at the full scene; then move the shutter speed scale one step to the right for taking the picture. (Example: The reading is 1/200. Move the shutter scale to 1/100 second.) The rules for back-lighted subjects also apply to color pictures. In fact, very judicious measuring is essential for all color pictures. Whenever possible, use the close-up measuring method for pictures of people. Where this is not possible, the following modification will be helpful:

Principal subject in the shade . . . use one-half step longer exposure

People in snow pictures use full step longer exposure

Scenes with much green foliage
(except in open landscapes) . . ., use one-half step longer exposure

Dull, overcast day use 1/2 to full step longer exposure

Always remember:

Don't cover the exposure meter cell window. Give the meter needle 2 to 3 seconds for correct reading. Measure the important part of the picture. Use close-up measurement whenever possible. Modify exposure times under certain conditions.

S-t-e-a-d-y!

Even the best photo-finisher can't give you a sharp print from a blurred film! Therefore, get used to a comfortable and steady hold of your MINOX during exposure. Some people can hold the camera perfectly still for 1/5 second; others have trouble even with 1/50 second. Experience will tell you whether you can get steady pictures at the slower shutter speeds. Generally, you will find it advisable to use a tripod or other firm support for 1/20 second and slower. For all snapshots, use the hold suggested on pages 4 and 5, and make sure that you "squeeze" the shutter to avoid jarring the camera.

How about longer exposures?

In a pinch, try holding your MINOX steady by leaning your elbows on a table or other firm surface, or against a wall; better still, place the camera on a support, ledge, etc. It is best, however, to attach the MINOX with the MINOX camera clamp to a tripod. You will find the MINOX pocket tripod a particularly fine and versatile accessory. Little larger than a pencil, it opens up into a rock-steady tripod complete with a swivel top; you can use it on a table, chair, window sill, or lean it against a wall. You can also brace it against your shoulders. As an extra precaution against jarring the camera, always use a cable release for tripod exposures. The MINOX tripod comes with its own cable release!

"Frame" your subject

Advance planning of composition saves extra work in enlarging, and gives you precisely the picture you want every time. Since the MINOX viewfinder shows you the exact picture area, you can easily compose each picture before you actually take it, you can omit unimportant or disturbing details right at the start, and fill the picture area to best advantage.

Close-ups of small things



There is a special fascination in a big close-up. A frame-filling picture of a single blossom showing the delicate details of each petal can be more rewarding than a whole acre of flowers. Therefore: Get CLOSE to the subject! Your MINOX offers you the great advantage that you can get as close as 8 inches without any supplementary equipment or extra lenses. Make the most of this excellent feature. Always use the measuring beads of the chain to determine the correct distance, and set the distance scale of the camera accordingly; this is important because, at close range, the zone of sharpness is very limited.

For instance, when the distance scale is set at 1 ft. the sharpness extends only from 11 inches to 13 inches. Now you know why accurate distance setting is a must for extreme close-ups. Remember also that, at distances between 8 and 10 inches, the picture area lies a frame-width within the luminous frame of the viewfinder.

Hot Weather Precaution



Films are sensitive to high temperatures.

Do not store MINOX films or your loaded MINOX in the glove compartment or window-shelf of your car, where the film may be affected by excessive heat.

How to stop moving subjects

Sports and other fast action call for high shutter speeds -- otherwise your pictures may be blurred. But even under unfavorable light conditions requiring slower shutter speeds, you can stop motion by using some professional tricks. For example, it is easier to stop motion of a subject moving straight toward the camera, or at a slight angle, than it is to "freeze" a subject moving at right angles to the camera. Or, watch for the moment of "suspense" such as is reached by a swing at its highest point just before it moves down again, or by a tennis player during the serve when the ball is at the peak of the toss, and the racquet is about to be swung. Even 1/20 second will "stop" such shots. Here is another well-known professional trick that will help you get fine results with very fast motion--automobile races, speed boats, skiing, etc.: Keep the car, boat, or skier centered in the MINOX viewfinder and follow the motion with the camera, releasing the shutter at any instant during this panning. The background will be blurred, adding to the impression of speed, but the subject stays sharp even at 1/50 second.

Flash Pictures

The MINOX has built-in flash synchronization, which actuates the flash when the shutter button is pressed. Any flash unit may be used with the MINOX. There are two basically different types of flash units: Electronic flash units and units using expendable flash bulbs. Electronic units are equipped with a flash tube. The initial cost of such units is higher but, generally speaking, the operating expense is negligible. Because of the extremely high speed of electronic flash, even fastest motion can be "frozen". The MINOX B/C Flashgun is particularly convenient. This uses AG1 Bulbs. Small flash units may be attached to the chain socket of the MINOX B by means of the flash adapter. For use with large flash units the MINOX B may be attached to a flash bracket by means of the MINOX camera clamp (see page 44).

Electronic Flash can be used with any shutter speed up to 1/500 second. The shorter the shutter speed, the greater the influence of the flash upon the illumination and character of the picture. For electronic flash units of medium brightness, use films of 13 or 14 DIN. All pictures to about 18 - 25 feet will be well exposed. The differences in the negative quality are so slight that they do not affect the enlarging ability. For short distances (less than 10 ft) the effect of the flash can be cut in half by using the green filter (neutral density grey filter should not be used). Since electronic flash units usually emit very harsh light, the following suggestions will be helpful in reducing the extreme brilliance:

1. Detach the flash unit from the camera and use it at a greater distance and to the side of the camera. An extension cord for this purpose is available at your MINOX dealer. Be careful however that the shadow of the camera does not show in the picture.
2. Hold white paper or thin white fabric (handkerchief, for instance) in front of flash reflectors; this not only reduces the intensity of the light, but makes it considerably softer.

Flash bulbs can be used at shutter speeds up to 1/20 second. The usual capless bulbs may be used as readily as the larger types. Flash units with built-in condensers (B/C) such as the MINOX Flashgun are preferable because they assure perfect flash timing even after many months use of the same battery.

To reduce the flash intensity with flash bulbs at closer distances, you can use the same methods recommended for electronic flash above.

It's a colorful world

The 15 mm f/3.5 Complan lens of your MINOX is fully color corrected, and has an anti-reflection coating -- in other words it is ideally suited for color photography.

If you have never taken color pictures before, keep in mind the following points to help you get fine results:

Color film yields the best results in bright or hazy sunlight; on overcast days, results are usually disappointing.

The best time for color pictures is mid-morning and mid-afternoon. Around noon, the light is usually bluish, resulting in very 'cold' colors or an over-all bluish tinge. During the hours just after sunrise, or before sunset, the light is more reddish, resulting in very 'warm' colors.

Watch for the possibility of color reflections (which may not be noticeable to the eye): A white dress on a green lawn is never pure white, but faintly green! Color film requires careful exposure measurement; even slight deviation from the correct exposure may result in false color reproduction. (Read the suggestions about exposure on page 29).

Under-exposure results in dark colors, over-exposure produces pale pictures with washed-out colors.

As a general rule, color pictures are best taken with the sun slightly to one side behind the photographers back.

Avoid deep shadows on faces, and strong contrasts between light and dark portions of a scene.

If you are seriously interested in all phases of color photography, you will find it worthwhile to read one of the many comprehensive books covering this field.

For more fun with your MINOX - - read "Small MINOX--Big Pictures" the entertainingly written complete guide to MINOX photography which explains and illustrates every use of your MINOX and its accessories. Beautifully printed on coated paper, and bound in linen, this pocket-size book tells the full MINOX story. You will enjoy reading it, and it will help you improve your own MINOX technique. "Small MINOX--Big Pictures" is for sale at your MINOX dealer's.



Copying of documents, drawings, books, etc. is no problem for your MINOX. By using a tripod, MINOX Copying Stand (see page 46), MINOX Copying Arm, or other means of support, you can conveniently copy such material, getting as close as 8 inches for largest possible reproduction.

Use the special MINOX ASA 5 Micro Copy (Doku-Ortho) film, except when copying illustrations or photographs containing half-tones for which the regular ASA 25 film should be used. (See back flap of this manual for areas covered at various distances).

Left MINOX copy of an engraving by Marltin Schongauer. Micro Copy - ASA 5 film.



Changing the film type

Some day you may want to take color pictures just when your MINOX is loaded with black-and-white film -- or vice versa.

When you want to change cassettes, pull-push the camera once to transport the last-exposed film frame into the take-up end of the cassette. **Change the ASA setting of the meter for the next film (s. p. 20) before you open the back of the camera.** Remove the cassette from the camera (see page 23); note the number showing on the exposure counter, and write this number on the cassette for future reference.

Insert the new cassette after you have set the exposure counter to the red dot, (see page 19), and proceed in the usual manner.

When you re-load the "started" cassette: **Change the ASA setting of the meter;** then set the exposure counter three numbers back from the number which you noted when you originally removed the cassette. Example, if you removed the cassette at "28", set counter at "25". Now insert cassette in the usual manner. Pull-push the camera three times. This takes up any slack in the cassette and gets your MINOX ready for the next picture.

Right: Snapshot with electronic flash by Dr. G. Busch ASA 25 film.

WHAT HAPPENED?

You'll find it easy to get the "feel" of your MINOX within a short time, and to get a succession of fine pictures. If you should have a failure at one time or another, check it against these possible errors and learn to avoid repetition:

... IF the principal subject is not sharp:

The distance scale was not set correctly. Always set the distance carefully, especially for close-ups. (Use the measuring chain for extreme close-ups). OR

The motion of the principal subject (car, boat, skier) was too fast for the shutter speed used.

... IF there are blurred or double outlines:

The camera moved during exposure; (hold camera steady or use tripod for longer exposures; sometimes a table, chair or a wall will support the camera adequately).

... IF your pictures have a blurred shadow at the right, or at the bottom:

Your finger got in front of the lens! Watch your camera holds check it against the illustrations on pages 4 and 5.

... IF your pictures look cruddy and out of focus:

There's probably a fingerprint or smudge on the lens window of your MINOX Clean the window carefully (see page 26).

... IF your film shows irregular spacing or overlapping:

Either you forgot to set exposure counter at the red dot (page 19) when you started the film, or you did not pull and push the camera ALL THE WAY between exposures (page 3).

... IF some of your negatives are very thin or almost black:

- (a) Exposure meter was set to wrong ASA number (page20);
- (b) Exposure meter window was partly obscured during measurement (page 4);
- (c) Exposure meter button was not held down for several seconds (page10).

..... If some prints show more "grain" than others from the same film:

Badly over-exposed pictures have coarser grain. Over-exposure is as undesirable as under-exposure. Make sure you use the exposure meter properly.

... IF film has thin horizontal scratches (telephone wires):

Dust is the enemy of your MINOX films. Never carry a film cassette in your pocket without a wrapper. Before loading the camera, blow out any dust particles which may have lodged in the film compartments (page 27).

... IF the film cassette won't drop easily into the camera when loading:

The film gate **must be open** when the film is dropped into the camera. Be sure to push the camera (with open back cover) together about 1/8" to open the film gate (see page 21).

... IF the film cassette cannot be pulled out of the camera:

It's the film gate again! See previous paragraph.



... IF the film cassette does not lie flush in the camera, so that the back cover cannot be easily closed:

This is not your fault. It may happen on rare occasions when the film take-up core rests on the teeth of the transport wheel in the film compartment of the camera. Simply lift out the cassette, pull camera open all the way, and close again just enough to open the film gate. Re-insert the cassette. Close cover.

... IF the film shows dark areas at intervals along the edges:

Either the cassette was handled in very bright light before or after loading; or the film was advanced beyond the red dot before unloading which may result in light entering through the film slit of the cassette.

A pleasant MINOX snapshot by Werner Schmolcke: ASA 25 film, 1/200 Sec.

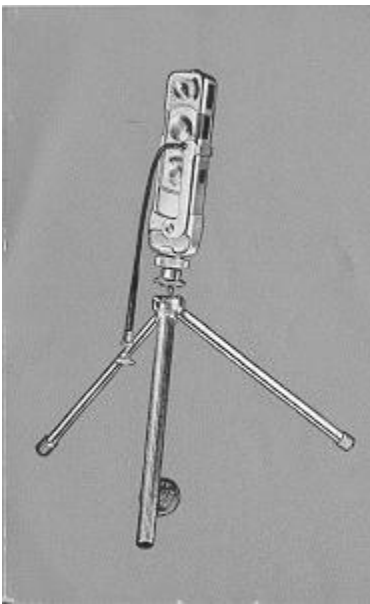

MINOX Camera Clamp

The Camera Clamp is used to attach the MINOX to a tripod, or to the bracket of a flash unit. It has a socket for a cable release which should be used for all tripod shots.

MINOX Pocket Tripod

Here is your best insurance for perfect pictures with the slower shutter speeds! Extremely compact, yet sturdy and versatile, the MINOX tripod even has an adjustable swivel head, The legs slide all into one so that the whole unit can be carried like a pencil, and a cable release is included, hidden and protected inside the tripod legs.



MINOX Slide Projector

There is no greater thrill than seeing your fine MINOX color slides projected on a screen. All the subtleties of color are brought out in projection.

The MINOX Slide Projector is designed especially for MINOX slides. It has an efficient light system with a 100 Watt projection bulb, silvered concave glass reflector, and aspherical condenser lens. Triple wane construction of the all-metal housing assures free air circulation for constant ventilation of the lighting system. A heat absorbing filter gives added protection to the transparencies during projection. The projection lamp can be adjusted for perfect illumination over the entire picture area.

Built-in front elevating micrometer screw permits height adjustment to centre the projected image on the screen.

MINOX transparencies for projection in the MINOX Slide Projector should be mounted in MINOX 30 x 30 mm transparency mounts. The Projector is supplied complete with projection bulb, slide changer, and plastic carrying case.

It is fitted with either the bright f/1.6 35 mm "MINOLUX" lens or the f/2.7 MINOSTAR.

Other useful accessories for the MINOX B







The MINOX Binocular Attachment permits taking tele-photographs through most better binoculars.

With the MINOX Finder Mirror true-to-life, you can take candid snapshots "around the corner"! You stand at a right angle to the subject.

The MINOX Adjustable Copy Stand makes easy work of copying letters, documents, books, etc. It folds for easy pocket carrying.

You can examine your negatives with the MINOX Negative Viewer without removing them from the transparent MINOX Negative Wallet.

	<p>The MINOX Flashgun (battery-capacitor type) just fits over the end by the camera.</p>
	<p>The MINOX Transparency Viewer-Cutter is ideal for examining your color films before mounting; a squeeze of the handle cuts each frame neatly to the exact size for the MINOX 30 x 30 mm Transparency Frames.</p>
	<p>Developing of MINOX films becomes a simple and convenient matter with the MINOX Daylight Developing Tank; of course, you don't need a dark room! .</p>
	<p>The MINOX Enlarger is designed especially for getting the very best results from your films; its critically corrected 15 mm f/3.5 lens matches the superb quality of the Complan lens in your MINOX camera.</p>

INDEX

<p>Accessories 44 - 47</p> <p>ASA Settings 20, 21, 28</p> <p>Binocular Clamp 46</p> <p>Cable Release 15, 44</p> <p>Chain, use of 8, 26, 32</p> <p>Changing Film Type 38, 39</p> <p>Cleaning the Camera 27</p> <p>Close-ups 8, 32</p> <p>Color Photography 28, 30, 36</p>	<p>Copy Film 28</p> <p>Copying 38</p> <p>Copying Stand 38, 46</p> <p>Depth of Field 6; 7, 8</p> <p>Depth of Field Bracket 6,7,8</p> <p>Developing Tank 47</p> <p>Distance Scale 6, 7, 8</p> <p>Distance Setting 6, 7, 8</p> <p>Electronic Flash 34</p> <p>Enlarger 47</p> <p>Errors 40 - 43</p> <p>Exposure 9,10,11, 12</p>	<p>Exposure Counter 19</p> <p>Exposure Measurement '29, 30</p> <p>Exposure Meter 10, 11, 12, 20</p> <p>Faults 40 - 43</p> <p>Film 28</p> <p>Film Advance 3</p> <p>Film Change 38, 39</p> <p>Film Gate 21, 23</p> <p>Film Loading 20</p> <p>Film Unloading 23</p> <p>Filter Slide 14, 25</p>
--	---	---

Filters 12,14, 24, 25	Pocket Tripod 44
Finder s, 19	Projector 45
Finder Mirror 46	Release 5
Flash 17, 34	Sharpness Zone 6, 7, 8
Focusing 6, 7, 8	Shutter 9
Grain 28, 41	Slide Projector 45
Grey Filter 14,15, 24, 25	Snapshot Setting 6, 7
Green Filter 12, 24, 25	Telephotography 46
Holding Camera 4, 31	Telescopic Rapid Wind 3
Landscapes 8	Time Exposure 15,16, 31
Lens Window 3, 26	Tripod 44
Luminous Frame Finder 5,19	Tripod Clamp 44
Neutral Density Filter 14, 15, 24, 25	Viewfinder s, 19
Picture Area 19	Zone of Sharpness 6, 7, 8



Figures in light type apply when distance scale of camera is set exactly half-way between two adjacent engraved distance markings.

For convenient measuring of close distances, the MINOX chain is equipped with beads at 8"--10" -- 12" --18 "

Distance chart: Distances are measured from the front of the camera.

Distance Focused On	Subject / Field Size – inch.	Depth of Field
∞ Infinity	–	12' 8" to ∞
12'	105 x 77	6' 1½" to ∞
6'	53 x 38	4' to 11' 4"
4'	35 x 25½	3' ½" to 5' 11"
3'	26 x 19	2' 5⅞" to 3' 9½"
2' 4⅞"	20¾ x 15	1' 11⅞" to 2' 11¼"
2'	17⅛ x 12½	1' 8¾" to 2' 4½"
1' 8¾"	14⅞ x 10⅞	1' 6¾" to 2'
1' 6"	12¾ x 9¾	1' 4⅞" to 1' 8½"
1' 2¾"	10½ x 7½	1' 1⅞" to 1' 3⅞"
1'	8⅞ x 6	11⅞" to 1' 1"
10⅞"	7½ x 5⅞	10⅞" to 11¾"
10"	6¾ x 4⅞	9¼" to 10¾"
8⅞	6 x 4⅞	8¾" to 9½"
8"	5⅞ x 3⅞	7⅞" to 8½"