

Ricoh RZ-3000

This camera manual library is for reference and historical purposes, all rights reserved.

This page is copyright by mike@butkus.org M. Butkus, NJ.

This page may not be sold or distributed without the expressed permission of the producer.

On-line camera manual library

If you find this manual useful, how about a donation of \$3 to:

M. Butkus, 29 Lake Ave., High Bridge, NJ 08829

**This will help me to continue to host this site,
buy new manuals, and pay their shipping costs.**

It'll make you feel better, won't it?

If you use Pay Pal, use the link below.

Use the above address for a check, M.O. or cash.



www.PayPal.me/butkus

Venmo @mike-butkus-camera

[Back to my main Camera Manual page](#)

We are most gratified that you have selected a RICOH camera. Before using your camera, please be sure to read these Instructions carefully.

LOCATING THE CONTROLS

- (1) Drive Dial
- (2) Distance Measuring Window
- (3) Shutter Release Button
- (4) Battery Compartment Cover
- (5) Strap Holder

(6) Remote Control Sensor

(7) AF Auxiliary Light Window Self-timer Lamp

(8) Lens

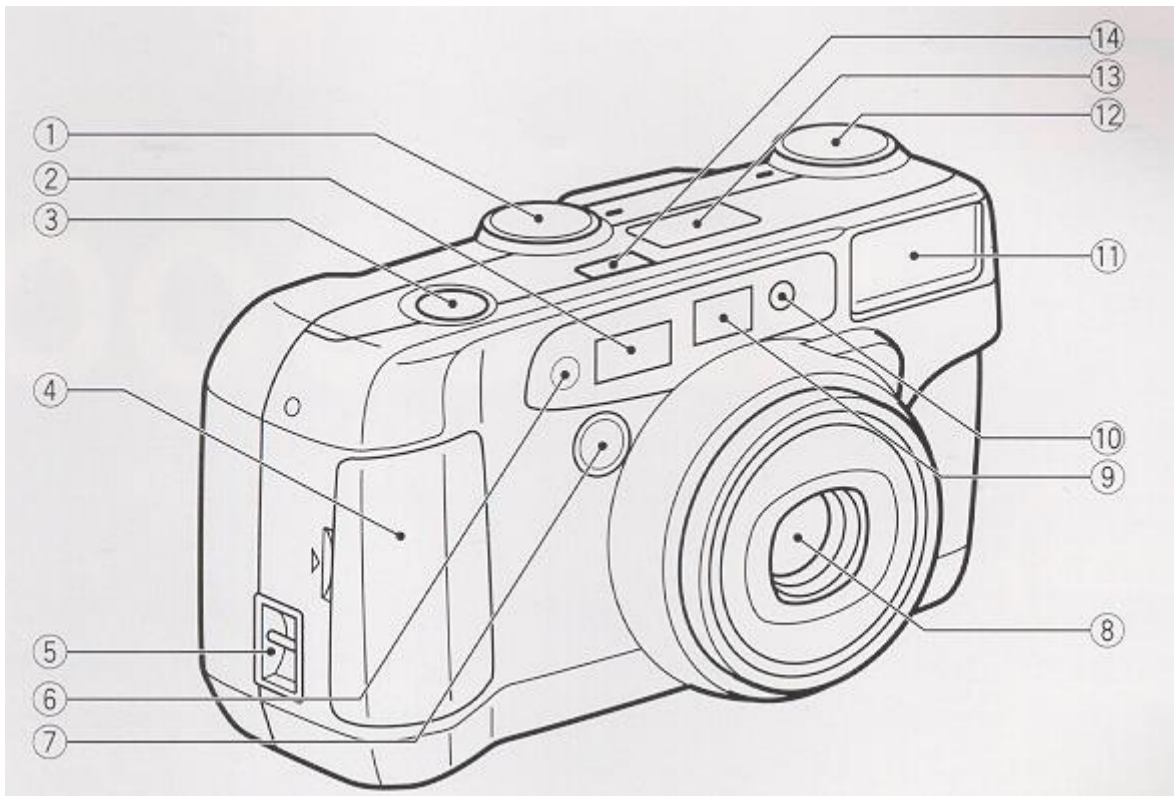

(9) Viewfinder Window

(10) Photocell

(11) Built-in Flash

(12) Mode Dial

(13) LCD Panel

(14) Flash Button

(15) Zoom Lever

(16) Flash Monitor

(17) AF Monitor

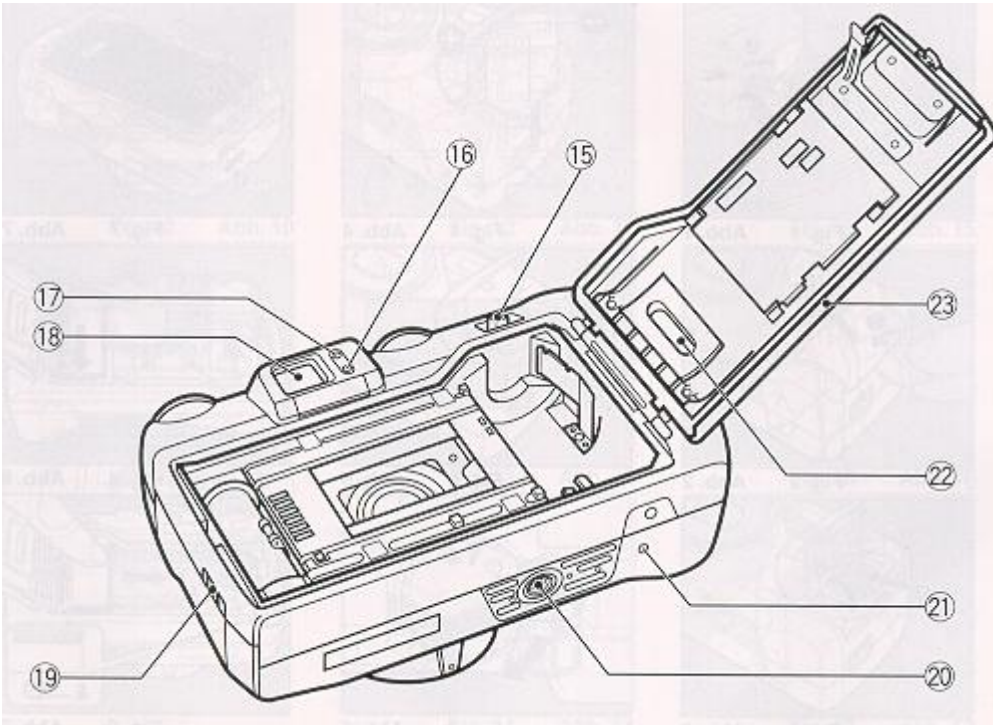

(18) Viewfinder

(19) Back Cover Latch

(20) Tripod Socket

(21) Manual Film rewind Button

(22) Film Loaded Window

(23) Back Cover

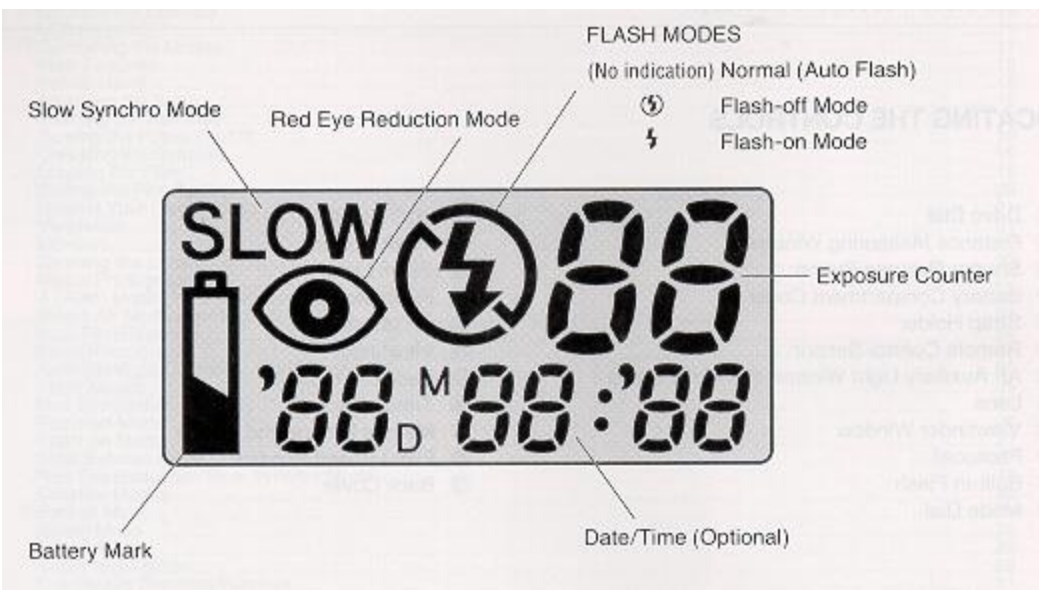

× Combining **the modes**

It is possible to set the camera to combine the Self-timer and Remote Control with the shooting modes and the flash modes. Some of the shooting modes can also be combined with the flash modes, as shown below.

Shooting Modes Flash Modes	A (Auto) Mode	Portrait Mode	Action Mode	Infinity Mode	Super Night Mode	Single AF Mode
Normal	O	O	O	x	O	O
Red Eye Reduction Mode	O	O	x	x	O	O O x x O
Flash-off Mode	O	O	O	O	x	O
Flash-on Mode	O	O	O	x	x	O
Slow Synchro Mode	O	x	x	x	x	O
Red Eye Reduction Slow Synchro Mode	O	x	x	x	x	O

MAIN FEATURES

- × Powerful 38-130 mm multi coated zoom lens with aspheric lens elements
- × 7-zone passive multi autofocus in 1024 measuring steps
- × High-power zoom flash for tele shooting
- × Easy to access 2-dial control with illuminator
- × Creative modes (portrait, action, super night, infinity, etc.)
- × Compact and light weight body

BEFORE USING

- * A fast film such as ISO 200 or ISO 400 is recommended to prevent blurriness and to obtain a longer flash range.
- * When focusing is difficult or impossible, AF monitor blinks to warn you that an out-of-focus picture will occur. Set infinity mode or use focus lock function. (page 24, 29)
- * Do not hold the camera by the lens
- * Before taking important pictures (at weddings, on trips abroad, etc.) test the camera and learn how it works.

CAUTIONS

This camera has a high voltage circuit. Because it is dangerous, do not attempt to take the camera apart.

If the built-in flash does not operate, do not touch the internal parts of the camera, as it contains a high voltage circuit. Take the camera to the shop where it was purchased, or to your nearest Ricoh service center.

ATTACHING THE STRAP

1. Insert the small loop at the end of the Strap under the Strap Holder. (Fig. 1 (a))
2. Insert the other end of the Strap through the loop to tie the Strap onto the Strap Holder (Fig. 1 (b))

INSERTING THE BATTERIES

The camera will not operate unless the batteries are installed. Make sure that the batteries are installed correctly.

1. Insert a coin in the slot of the Battery Compartment Cover to open it. (Fig. 2)
2. Slide the inner cover latch in the direction indicated to open. (Fig. 3)

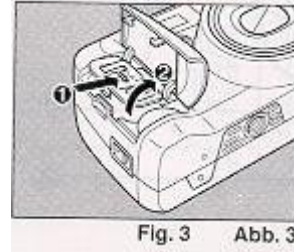
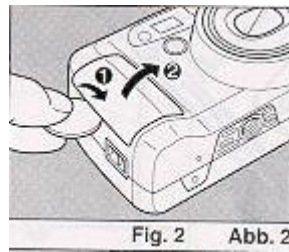
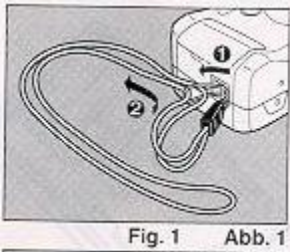

3. Insert the recommended 3 volt lithium batteries, checking that the + and - are inserted correctly. (Fig. 4)
4. Press down the inner cover to close.
5. Close the Battery Compartment Cover by pushing it in the direction indicated until it locks firmly in place. (Fig. 5)

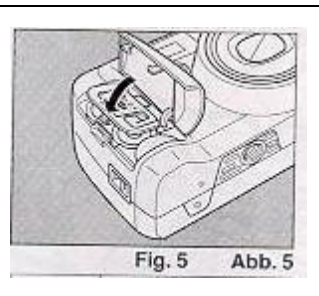
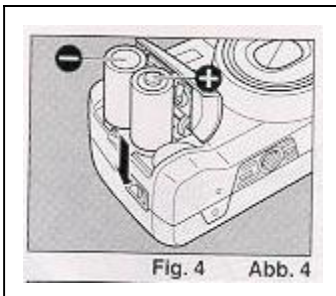

* Do not remove the batteries from the camera until you are ready to replace them.

* The date display ["00 0 0] blinks when the batteries are replaced. By pressing either the Mode Button, Select Button, or Set Button, [1 1 '95] will be displayed. Reset the correct time and date. (Optional)

* When replacing the batteries, do so as quickly as possible to avoid erasing camera memory. We recommend replacing the batteries when there is no film in the camera.

* **The batteries can explode or cause burns if disposed of in fire or if shorted, disassembled, heated or recharged.**

* **Recommended Replacement 3V Lithium**

Batteries

CR-123A, or equivalent X2

TURNING THE POWER ON/OFF

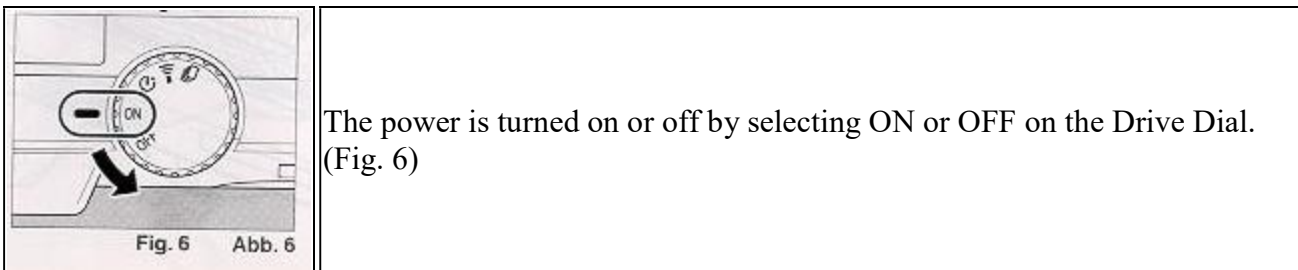

When the power is turned on, the lens moves from the storage position to the wide-angle position, and the camera is set automatically to the mode selected on the Mode Dial.

CHECKING THE BATTERIES

1. When the batteries are nearly exhausted,  will appear on the LCD Panel. Replace with new batteries as soon as possible.

2. When the batteries are exhausted, the  symbol will blink in the LCD Panel. Replace with new batteries.
* As the battery voltage is reduced in extremely cold temperatures, the do symbol may blink. You may be able to use the camera if you remove the batteries and warm them up.

* In the following cases, battery voltage is insufficient and the batteries need to be replaced.

1) When the power does not turn on.

2) When the  symbol blinks.

3) When the shutter does not release.

4) When film advance or rewind do not function.

5) When the Self-timer does not function. * To avoid tripping the shutter inadvertently and wasting battery power, always turn the power off when you are not taking pictures.

* If the camera is not operated (buttons, dials and lever) for about 5 minutes, the power automatically turns off, the LCD Panel display disappears and the lens returns to the storage position. The purpose of this function, called Auto Power OFF, is to prevent waste of battery power. The power will turn on again by operating any of the buttons, dials or lever.

LOADING THE FILM

Always avoid direct sunlight when loading the film.

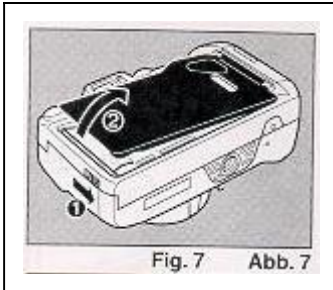

1. Push the Back Cover Latch Downward to open. (Fig. 7)

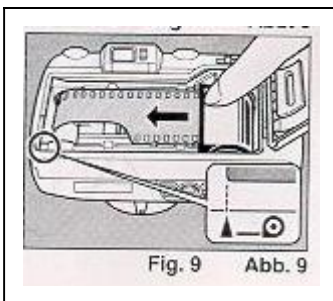

2. Load the film cassette into the Film Chamber and pull out enough film leader to extend past the mark of the film leader position. (Fig. 8, 9)

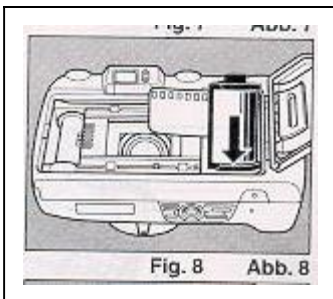

* If there is any dust on the inside lens surface, use a blower to blow the dust away.

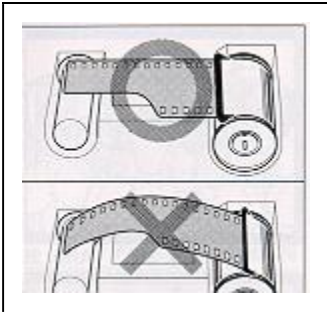

3. Make sure the film stays within the Film Guides and lies flat. (Fig. 10,11)

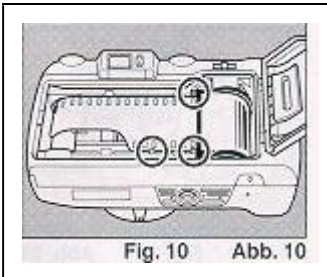

4. Press the Back Cover shut so that the Back Cover Latch returns to its original position. When you close the Back Cover the film is automatically advanced, and the first frame is set in place. The Exposure Counter on the LCD Panel displays the number of frames remaining to be exposed. (Fig. 12)

Fig. 10 Abb. 10

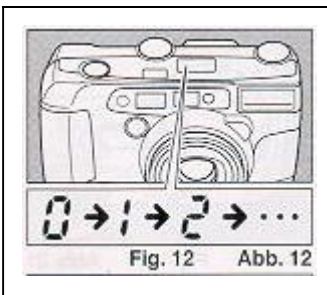

* If the film has not advanced correctly and is not taken up onto the Film Take-up Spool, the Exposure Counter will blink. (Fig. 13) The Shutter Release Button will also lock so you cannot take a picture until the film is loaded properly. (DX Film only) Reload the film by following steps 1 -4 shown above.

Fig. 12 Abb. 12

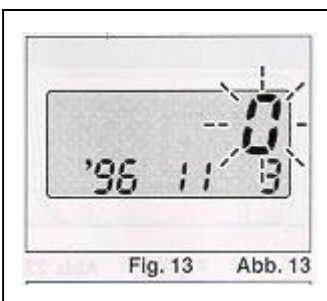

* Whether there is film in your camera or not can be confirmed by either the Film Loaded Window or the Exposure Counter in the LCD Panel.

* You can confirm that the Film-Wind or Rewind is working properly by observing the Exposure Counter.

Fig. 13 Abb. 13

* You can load film in your camera with the power off. However, the LCD Panel display will disappear after loading is complete.

* Do not touch the inner lens with your fingers or the edge of film.

* This camera's Pre-wind System automatically rewinds the film to the end when you load it and rewinds it back into the film cassette as each shot is taken. If the back cover is accidentally opened before the film has reached the end, close it immediately. The film will automatically rewind. When it has completely rewound, the Exposure Counter will display "E". Remove the film and develop.

* Sometimes more exposures can be taken than the standard number of frames listed on the film. For this reason, the number of frames counted in the Exposure Counter on the LCD Panel may sometimes be higher than the number of frames listed on the film.

SETTING THE FILM SPEED

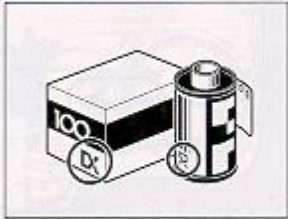

Fig. 14 Abb. 14

DX-coded film cassettes have black-and-silver patterns corresponding to film speeds that the camera reads and automatically sets. Your camera accepts DX films with speeds ranging from ISO 50 to 3200. (Fig, 14)

Most color negative films on the market are DX-coded. When using DX-coded films, setting the film speed is not necessary. Your camera automatically sets the correct film speed.

When using a film without a DX code, your camera will automatically set itself to ISO 100.

HOLDING YOUR CAMERA



Fig. 15 Abb. 15

1. Always use both hands to steady your camera. (Fig, 15)



Fig. 16 Abb. 16

* When holding the camera vertically always position it with the flash at the top. (Fig. 16)



Fig. 17 Abb. 17

* Be careful not to place your fingers over the lens, flash or focusing windows. (Fig. 17)

* We suggest that you become familiar with your new camera by shooting and processing at least one roll of film before using your camera to record an important occasion.

* If the camera moves during the exposure, the whole picture will be blurred. To help insure sharp pictures, hold the camera steadily and properly.

VIEWFINDER (Fig. 18)

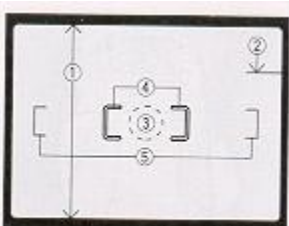

Fig. 18 Abb. 18

(1) Field of View Frame:

The subject (such as people or scenery) you wish to photograph should be contained within the frame.

(2) Parallax Correction Marks (Close Focusing Telephoto)

When taking a picture of a subject that is between m-1.8 m (3.3 ft.-6 ft.) away from your camera, the subject should be positioned within this mark. Any thing outside the marks will not be included in the picture even if you can see it through the viewfinder

(3) Single AF Spot

The center spot of multi auto focus mark (in wide)

(4) Multi Auto Focus Marks (in Wide)

(5) Multi Auto Focus Marks (in Tele)

MONITORS

When the Shutter Release Button is pressed lightly, the AF Monitor and the Flash Monitor on the right of the viewfinder will either light up or blink to indicate the following.

AF Monitor (Green)

Display	Description	Shutter	page
Lights up	Subject is in focus	Shutter Shutter will release	pg. 21
Blinks	Subject is out of focus	* Shutter Shutter will release	pg. 21
Blinks	Subject too close	Shutter will not release	pg. 21

* In certain cases the shutter will not release. However, this is not a malfunction.

Flash Monitor (Red)

Display	Description	Shutter	Page
Lights up	Subject within flash range	Shutter will release	P.23
Blinks	Flash is charging	Shutter will release	P.23
Blinks rapidly	Subject out of flash range	Shutter will release	P.23

ZOOMING THE LENS

The built-in 38-130 mm zoom lens lets you get more in the picture, or closer to your subject without changing your position. This allows you to easily select the composition that best suits your subject. **(Examples 1, 2)**

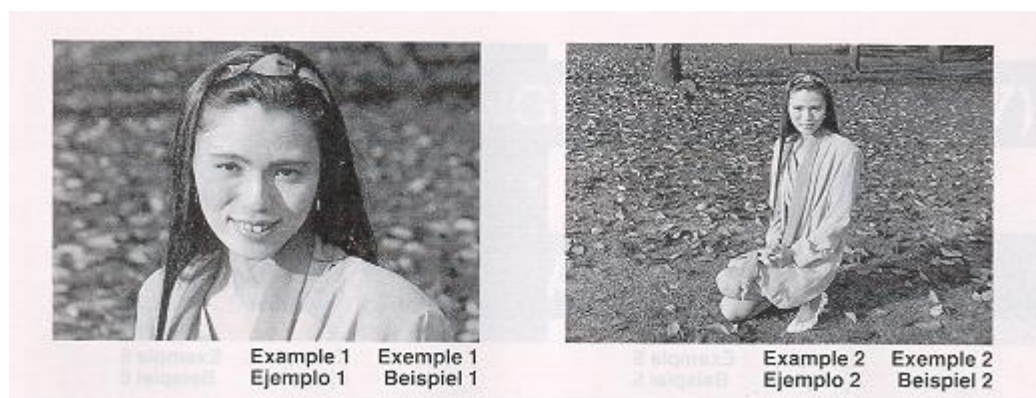

To zoom the lens, just turn the zoom lever to the led for Tele or to the right for Wide until your subject is framed properly. (Fig. 19)

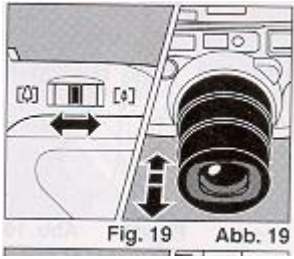

- * When zooming the lens, keep your fingers away from the moving lens components.
- * When the power is turned off, the lens will return to its storage position automatically.
- * To save on battery life, after about 5 minutes of inactivity, the lens will return to the Storage Position and the display on the LCD panel will disappear.

When zooming to the telephoto end, be sure to hold the camera firmly to prevent camera shake.

MACRO PHOTOGRAPHY

Used for close-up photography of flowers, etc. **(Example 3)**

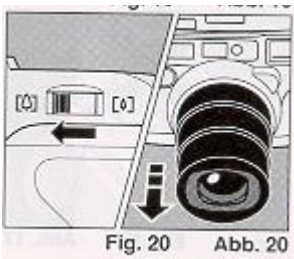

1. Turn the zoom lever to the left to set the 130 mm position. (Fig. 20)
2. If necessary, approach to the minimum distance of 1 m (3.3 ft.) and release the shutter gently.

* At 130 mm, the magnification at the minimum distance of 1 m (3.3 H.) is approximately 1/7.1 times.

A (AUTO) MODE (MULTI AUTO-FOCUS MODE)

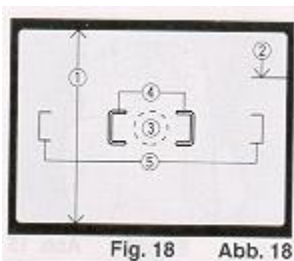

1. Turn the Mode Dial to **A**. **(Fig. 21)**
2. Set the subject you wish to take within the multi auto-focus area in the center of the viewfinder. (Fig. 18, Viewfinder)

The multi auto-focus area changes depending on the lens position (wide or tele).

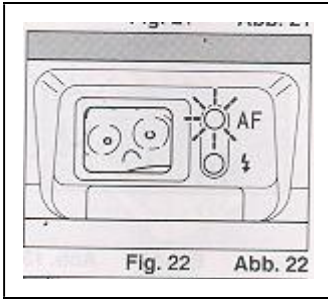

3. Press the Shutter Release Button gently to avoid camera shake.

If the subject is closer than 1 m/3.3 ft., the AF Monitor blinks and the shutter will lock to prevent out-of-focus pictures. **(Fig. 22)**

The distance between the subject and the camera is measured in 7 zones within the multi auto-focus marks. Among these zones, focusing will be adjusted to the closest subject. This function will help prevent out-of-focus pictures.

* The AF system uses an actual image of the subject to focus properly. In low light conditions, the AF Auxiliary Light automatically lights momentarily to provide a bright target for the AF system to see.

In backlight conditions, make sure the subject is in the center of the multi auto-focus area. Otherwise, the camera cannot detect the backlit condition, and even if the subject is less than 6 m/20 ft. away, the flash will not fire.

When the subject is difficult to focus on:

The autofocus sensor determines precise focus by reading the contrast of the subject. In certain rare situations, there may not be enough contrast for proper focusing. For example, clouds, hazy mountains, white walls and dark subjects that do not reflect light well.

In these situations, the camera is designed to warn you that an out-of-focus picture may occur. It does so by blinking the green AF monitor in the viewfinder.

When this happens you should:

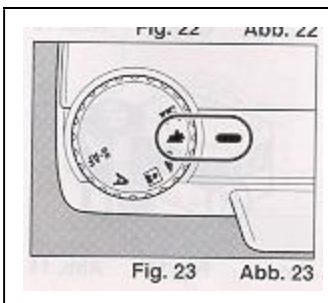

1. Turn the Mode Dial and select the Infinity Mode **(Fig. 23)** These modes automatically set the focus to infinity to assure sharp focus of long distance subjects.

2. Or for closer subjects use the "pre-focus technique" to lock the focus on a subject of equal distance but with better contrast. To do this simply hold the shutter release halfway down (while in the single autofocus mode) on a subject of equal distance and then recompose back to the original subject and continue to depress the shutter release button to take the picture (see single AF for additional details).

3. If you press the Shutter Release Button all the way down, the shutter can be released. At this time, focuses either at infinity in daylight or to the pair where AF system estimate in dark condition, to minimize out of focus pictures. * In very rare cases, however, shutter may lock such as strongly backlit subject, clear sky etc. Use prefocus shooting. **SINGLE AF MODE (PRE-FOCUS SHOOTING)**

Your camera's multi autofocus system will provide excellent results in most shooting conditions. However when the subject you wish to focus on is behind a window, fence or bars, or located high or low in the viewfinder, you should use pre-focus shooting. This will ensure a sharply focused image of your subject.

When the subject is high or low within the viewfinder:

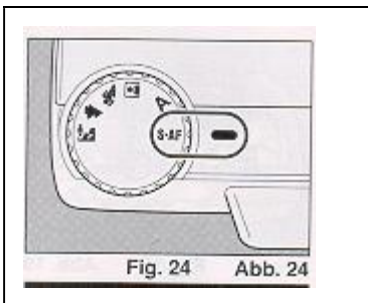

1. Turn the Mode Dial to S × AF. (Fig. 24)

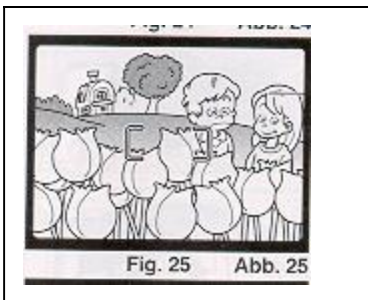

2. There may be cases where none of your main subjects are at the Single Auto-Focus spot located at the center of the viewfinder (eg. subject located high or low). If you release the shutter then, only the background will be in focus, and the subject will be out-of-focus. (Fig. 25)

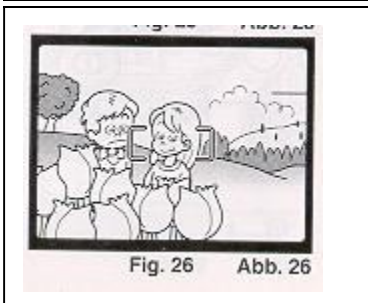

3. To pre-focus, move the camera so that one of the subjects is within the Single Auto-Focus spot. (Fig. 26)

Press the Shutter Release Button halfway so that the AF Monitor lights up. Keep holding your finger halfway down on the Shutter Release Button.



Fig. 27 Abb. 27

4. Now return the camera to its original position so that your main subjects are composed to your liking within the Field of View Frame again, and press the Shutter Release Button fully to take the picture. (Fig. 27)

When the subject is difficult to focus on:

1. When you are photographing subjects that are difficult to focus on, or if your main subject is behind other closer objects, then find another subject at the same distance from the camera. You can pre-focus on that subject in the same way as described above.

* If you are shooting through a window under low light conditions, aim the camera at a slight angle to the glass to minimize any direct reflection of the AF Auxiliary Light.

* When you release your finger from the Shutter Release Button, the pre-focus setting is cleared, so that you can pre-focus again as many times as you wish.

AUTO FILM REWINDING

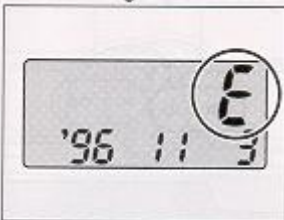

Fig. 28 Abb. 28

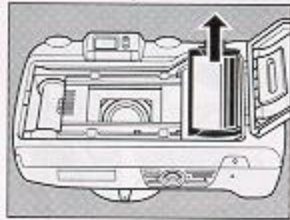

Fig. 29 Abb. 29

1. After the end of the film has been reached, the film will automatically rewind.

2. When the film is fully rewound, the motor stops automatically and "E" is displayed in the LCD Panel. (Fig. 28) Open the Back Cover to unload the film. (Fig. 29)

* If you wish to rewind the film before reaching the end of the film, push the Manual Film Rewind Button with a pen, etc. (If the Film Rewind Button is pressed with a pen whilst it is rewinding, the film leader will not be wound into the film cassette and will remain outside.) (Fig. 30)

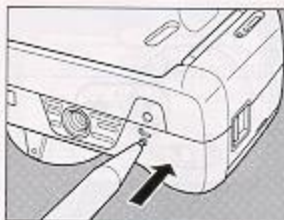

Fig. 30 Abb. 30

* Be careful not to touch the inner lens surface with your fingers or the edge of film.

FLASH PHOTOGRAPHY

1. If additional light is required, the built-in Flash automatically activates.

* Recommended Flash Shooting Range

(ISO 100)

Wide-angle: 1 m-5.3 m (3.3 H.-17.5 ft.)

Telephoto: 1 m-3.2 m (3.3 H.-10.5 ft.)

(ISO 400)

Wide-angle: 1 m-10.6 m (3.3 H.-35 H.)

Telephoto: 1 m-6.4 m (3.3ft. -21 ft. ft.) * To increase shooting range, use higher speed film such as ISO 400.

* To check if the subject is within the recommended flash shooting range, press the Shutter Release Button halfway. When Red Flash Monitor turns on steady, it is within the range, and when it blinks fast, it warns that the subject is out of the range.

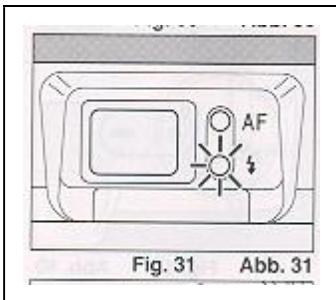

2. When the Flash is still charging, the Red Flash Monitor will blink and the shutter will be locked.

(Fig. 31) Wait until the red LED turns off in order to use the flash.

AUTO BACKLIGHT CONTROL/AUTO FILL FLASH

When taking pictures of backlit subjects, important details are often lost in the shadows. Your camera automatically compensates for these lighting situations. If the subject is backlit and is about 6 meters (20 feet) from the camera, Auto Back-Light Control (ABLC) will be activated. If the subject is within about 6 meters (20 feet) of the camera, the Flash activates automatically and the shadows are lightened up using automatic daylight fill-flash. Thus, with backlit subjects, natural looking pictures can be taken easily and automatically. (Fig. 32)

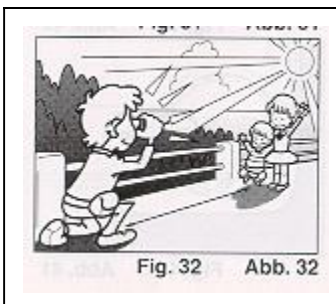

* Frame the subject in the center of the viewfinder to activate compensation.

FLASH MODES

The following Flash Modes can be selected by pressing the Flash Button:

? Red Eye Reduction Mode ? Flash-Off ? Flash-On ? Slow Synchro - Red Eye Reduction Slow Synchro

RED EYE REDUCTION MODE

Minimizing the Red-Eye Effect

Selecting this mode makes it possible to minimize the red-eye effect that sometimes occurs when taking portrait photographs with flash. Now it's easy for anyone to take superior shots of people.

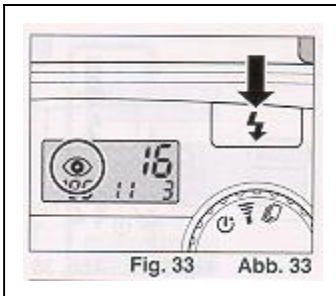

1. Press the Flash Button until the (eye) symbol appears on the LCD Panel. (Fig. 33)

2. Press the Shutter Release Button The flash system will begin its Pre-Flash Cycle. After a brief delay the Main Flash will then fire.

* Be sure to hold the camera still after pressing the Shutter Release Button.

You should advise your subjects that you are using Red Eye Reduction flash and they should wait for a second.

This mode is not cancelled when the camera is switched off.

* To cancel this mode, press the Flash Button again for any other selection.

Reducing Flash Output

The Flash adjusts the flash brightness to prevent excessively overexposed pictures when photographing, for example, fair skinned subjects at close range. This function works similarly in any of the Flash Modes.

FLASH-OFF MODE

This mode forcibly prevents automatic firing of the flash, thus allowing available light photography in museums, churches, etc. where flash photography is prohibited.

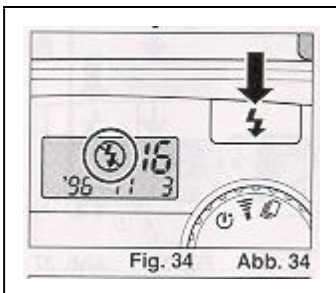

1. Press the flash Button until the ~ symbol appears on the LCD Panel. (Fig. 34)

2. Press the shutter Release Button and the Shutter will be tripped without flash.

* To cancel this mode, press the Flash Button until there is a different mode symbol (or none) on the LCD Panel.



* In dim light, the camera's shutter speed will be automatically reduced. Take particular care in Telephoto (130 mm) Mode. To prevent a blurry picture hold the camera steadily and press the Shutter Release Button gently.

FLASH-ON MODE

This forcibly trips the flash when you want to photograph subjects with sunlight to their side or back. It lets you take more natural looking pictures by softening harsh shadows.

Example 4: When the Flash-On Mode is set

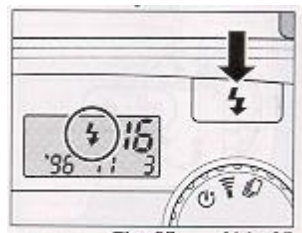
Example 5: When the Flash-On Mode is not set

 <p>Fig. 35 Abb. 35</p>	<ol style="list-style-type: none">1. Press the Flash Button until the  symbol appears on the LCD Panel. (Fig. 35)2. Press the Shutter Release Button. There will now be flash every time the shutter is tripped.
--	--

* The camera will follow a daytime Synchro-Sunlight Exposure program in cases of bright light.

* To cancel this mode, press the Flash Button until there is a different mode symbol (or none) on the LCD Panel.

SLOW SYNCHRO MODE

Use this mode indoors, at parties and in lighted rooms when you want both the subject and the background to be sharp. (Example 6)

With Auto-Flash and Flash-On modes the background may be dark because of the limited range of the flash light. (Example 7)

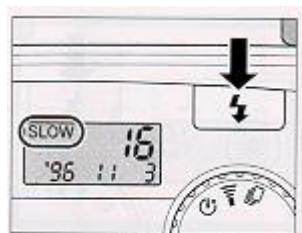
 <p>Fig. 36 Abb. 36</p>	<ol style="list-style-type: none">1. Press the Flash Button until SLOW appears on the LCD panel. (Fig. 36)
---	--

* To cancel this mode, press the Flash Button until there is a different mode symbol (or none) on the LCD panel.

* In dim light, the camera's shutter speed will be automatically reduced up to 2 sec. To prevent a blurry picture, hold the camera steady and press the Shutter Release Button gently.

(Take particular care in Telephoto (130 mm) mode.)

RED EYE REDUCTION SLOW SYNCH MODE

Set this mode to take red eye reduced slow synch photography.

; At the previous slow synchro mode, red eye reduction does not operate.

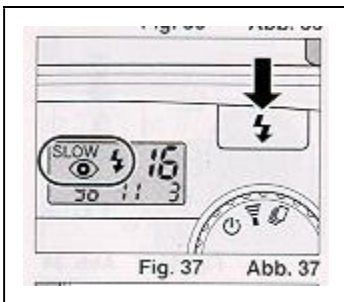

* Press the Flash Button until SLOW (eye with lightning bolt) symbol appears on the LCD panel. (Fig. 37)

* To cancel this mode, press the Flash Button until there is a different mode symbol (or none) on the LCD panel.

CREATIVE MODES

* Portrait Mode

* Action Mode

* Infinity Mode

* Super Night Mode

PORTRAIT MODE

Set this mode for shooting portraits. The camera is set to single auto-focus, the zoom sets automatically, and the flash fires even in daylight.

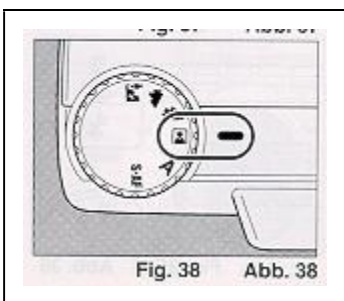

1. Turn the Mode Dial to the (person) symbol. (Fig. 38)

2. Press the Shutter Release Button lightly. The camera automatically zooms and the flash fires when the shutter Release Button is pressed completely.

* Use this mode to obtain photographs with a constant image size, even when the distance to the subject changes.

* If the Shutter Release Button is pressed lightly again, automatic zooming will also be repeated.

* The flash fires automatically in dim light. A soft flash also fires in sufficient-light conditions.

* If the Zoom Lever is used after pressing the Shutter Release Button lightly, automatic zooming will not operate. It will operate again after the Shutter Release Button is pressed completely.

ACTION MODE

Set this mode to maintain a moving subject in focus The camera is set to single auto-focus, and pictures can be taken continually for as long as the Shutter Release Button is pressed.

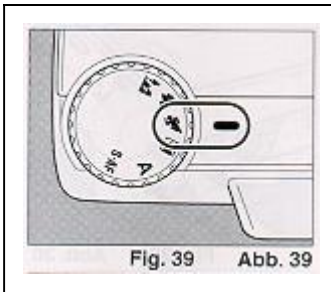

1. Turn the Mode Dial to the (person running) symbol. (Fig. 39)

* The shutter will release continually for as long as the Shutter Release Button is pressed.

* This mode cannot be combined with the Red Eye Reduction Mode or the Slow Synchro Mode.

* The camera may not focus on very fast moving subjects.

INFINITY MODE

Set this mode to take beautiful pictures of distant landscapes.

The camera focuses on infinity.

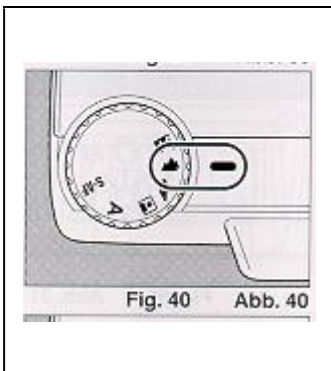

1. Turn the Mode Dial to the (mountains) symbol. (Fig. 40)

* When the Shutter Release Button is pressed, the camera focuses on infinity and the shutter is released.

* In dim light, the shutter speed becomes slow. Try prevent blurry pictures, use a tripod to keep the camera steady.

* The flash does not fire in the Infinity Mode.

SUPER NIGHT MODE

With the Super Night Mode, beautiful pictures can be taken at night. The camera automatically selects the optimum settings for pictures of night scenery, pictures of people at night (slow synchro photography), and evening or day landscape pictures. (Example 8)

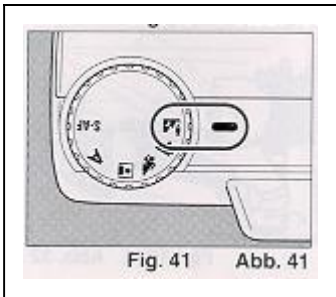

1. Turn the Mode Dial to the (picture of moon) symbol. (Fig. 41)

* Use a tripod to keep the camera steady.

2. Gently press the Shutter Release Button to take the picture.

For taking photos of people against a background of night scenery, the camera will first focus on infinity and open the Shutter for up to 2 second without flash. After closing the Shutter, the camera will then focus on the people and take another picture with the flash.

* By doing this, beautiful pictures focused on both the night scenery and people are possible. (The people have to within 6 m (19.7 ft.).

* When taking pictures of night scenery with no subjects, the camera will focus on (infinity). The flash will not fire, and the shutter will open for one second. (when there is no object within 6 m (19.7 ft.).

* When taking pictures of landscapes in bright daylight, the camera will focus on an (infinity) and set it self to Auto Exposure. If people are taken in bright daylight, the camera will set itself to daytime exposure program which will set the flash off.

Reference:

* To prevent blurry pictures from slow shutter speeds, we recommend the use of a tripod or remote electronic shutter.

* You may wish to advise your subjects not to move until the flash fires, to prevent blurred pictures.

* Also, we recommend that your subject sit on a bench or lean on a fence etc. to be stable.

* Use a wide 38 mm position to reduce the possibility of pictures with a blurred subject and to gain flash range.

* The following shooting modes are automatically selected depending on lighting of the subject and the shooting distance. (Using a ISO 100 film speed)

		Brightness of the subject	
		Dark (Less than 5.5 EV)	Bright (More than 5.5 EV)
Shooting Distance	Less than 6M	<p><Super Night Mode></p> <p>(Multiple exposure in (1) and (2))</p> <p>(1) Night scene photography Focusing: Infinity Shutter speed: Max. 2 sec. Flash: Does not fire</p> <p>(2) Shooting people Focusing: On the subject Shutter speed: Automatic Flash: Fires</p>	<p><Slow Synchro Mode></p> <p>Focusing On the subject Shutter speed: Automatic Flash: Fires</p>
	More than 6 m	<p><Night Mode></p> <p>Focusing: Infinity Shutter speed: Max. 2 sec. Flash: Does not fire</p>	<p><Infinity Mode></p> <p>Focusing: Infinity Shutter speed: Automatic Flash: Does not fire</p>

CONTINUOUS SHOOTING FUNCTION

This mode allows you to shoot continuously as long as the shutter is pressed.

You can accurately capture continuous action such as competitive sport events, moving subjects, and even the movements of an infant without missing any important moments.

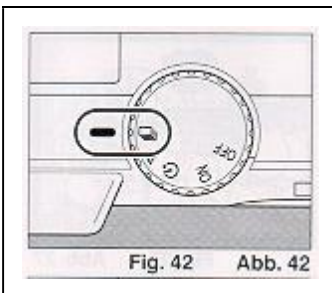

1. Turn the Drive Dial to the (multiple frame) mark. (Fig. 42)
- 2 Press and hold down the Shutter Release Button. Your camera will continuously take pictures at a rate of one frame per second as long as the Shutter Release Button is held down.

* Auto-focus in continuous shooting is set each time the shutter is released.

USING THE SELF-TIMER

1. Compose your picture with the camera on a steady support.

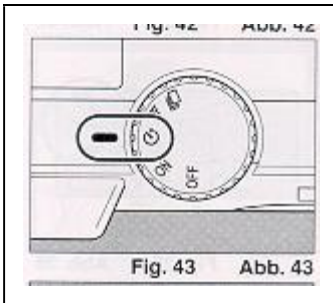

2. Turn the Drive Dial to the (clock) mark. (Fig. 43)

3. Press the Shutter Release Button.

The Self-Timer lamp on the front of the camera will light steadily for approximately 8 seconds. Then the lamp will blink for about 2 seconds to indicate that the Shutter is about to release. After a total of about 10 seconds have elapsed, the Shutter will release. (Fig. 44, 45)

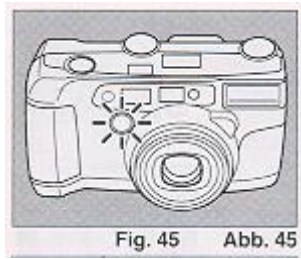
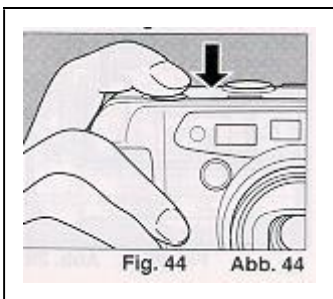

* If you wish to cancel the self-timer once it has started, turn the Drive Dial to a different setting.

Using the Self-timer for Flash Photography:

With Self-Timer photography the built-in Flash will fire automatically whenever there is insufficient light. * You may not be able to activate the Self-Time when the Flash is just beginning to recharge. Wait about 3 sec. for the flash to charge and try again.

* If the distance between the subject and camera is too close, the AF Monitor will blink. At that time, the Self-Timer will not activate. Move back a little and try again.

REMOTE CONTROL UNIT (RC-3/RC-3N) (SOLD SEPARATELY)

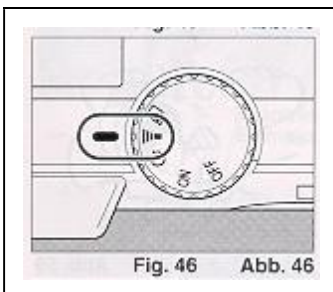

1. When you have decided the composition of your picture, and placed the camera on a steady support, turn the Drive Dial to (speaker) mark. (Fig. 46)

* Focus Lock cannot be used during Remote Control shooting.

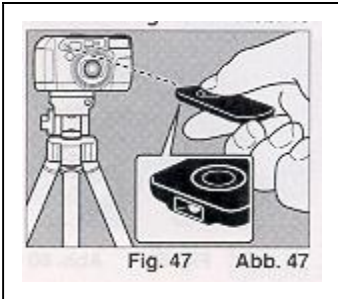

2. Aim the transmitter of the Remote Control Unit toward the front of your camera, and press the Transmit Button. (Fig. 47)

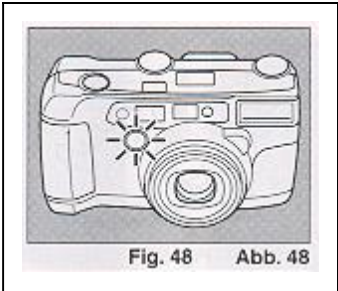

When the signal is received, the camera is focused automatically, the Self-timer Lamp lights up and after about 2 seconds the Shutter is released. (Fig. 48)

For another shot, repeat the procedure 2 above.

3. When you are finished shooting with the Remote Control Unit, turn the Drive Dial to a different setting. * The camera is focused when the signals from the Remote Control Unit are received.

* When the power is switched off, either by Auto Power Off or by the Drive Dial, remote control shooting is cancelled.

* Be careful to keep the transmitter of the Remote Control Unit clean.

* The operating life of the built-in battery of the RC-3 is about 2 years. If the camera stops responding to the Remote Control Unit, it is probably because the battery has run down. Take the Remote Control Unit to your Ricoh dealer. * Operating distance is within about 3.5 m-5 m (12 ft.-16.4 ft.), which varies depending on the angle of transmission to the camera.

(OPTIONAL) DATABACK SETTINGS

Nomenclature of the Date Imprinting Feature (Fig. 49) (most likely this will not show the date 2020)

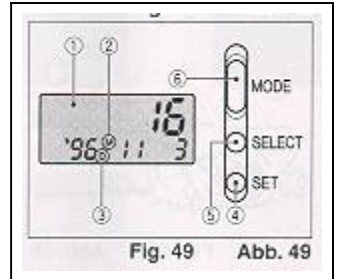

- 1. LCD Panel**
- 2. Month Indication**
- 3. Day Indication**

- 4. Set Button**
- 5. Select Button**
- 6. Mode Button**

Imprinting mode

Examples of Date Imprinting (Fig. 50)

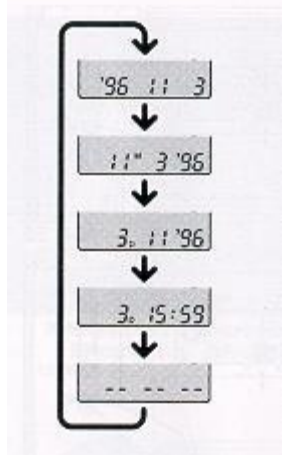
	<ol style="list-style-type: none"> 1. 1996 November 3rd. 2. November 3rd. 1996 3. 3rd. November 1996 4. 3rd. 15:59 5. No Imprinting <p>The Date Imprinting Mode can be divided into 5 types: Date, Time, and No Imprinting.</p>
--	--

Selecting Imprinting Mode (Fig. 50)

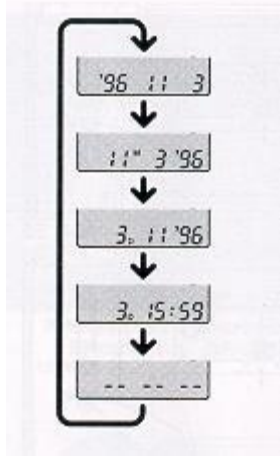

Each time the Mode button is pressed, the display changes as shown below. (Fig. 51)

	<ol style="list-style-type: none"> 1. Date (Year/Month/Day) 2. Date (Month/Day/Year) 3. Date (Day/Month/Year) 4. Time (Day/Hour/Minute) 5. No Imprinting
--	---

Resetting the Date and Time (Fig. 52, 53, 54)

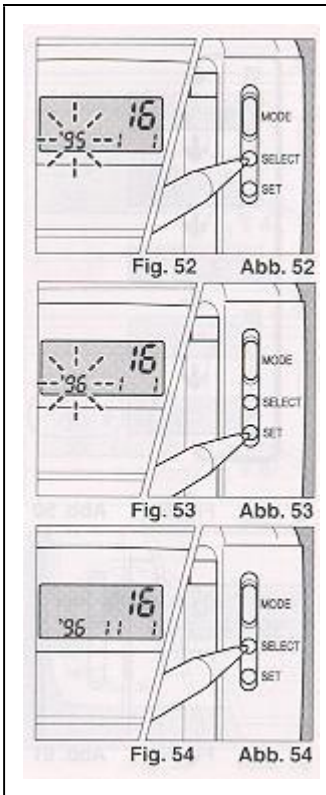

1. Each time the Select button is pressed the flashing digits change in the order of Year, Month, Day Hour and Minute

2. When the digits to be reset flash, press the Set Button until the desired digits appear. When the Set button is kept pressed, the digits change rapidly.

3. Imprinting is not possible when the date and time are being reset. When resetting is complete, press the Select Button until all digits stop flashing

Notes on Date Imprinting Feature * At temperatures below 0 ° C (32) ° F), the battery performance deteriorates. The Date Imprinting Feature may not function correctly and imprinting may become impossible.

* When the batteries are replaced, [00 0 Of appears and blinks in the LCD Panel. By pressing either the Mode Button, Select Button, or Set Button, [1 1 '95] will be displayed. Reset the correct time and date.

* The date is sometimes illegible if it is imprinted on the following objects.

- (1) "Warm" - colored objects, such as red, yellow orange, etc.
- (2) Objects with details similar in size to the imprinted date (gravel, leaves, etc.)
- (3) Objects of high luminance (sky, white wall, etc.)

PROPER CARE OF YOUR CAMERA

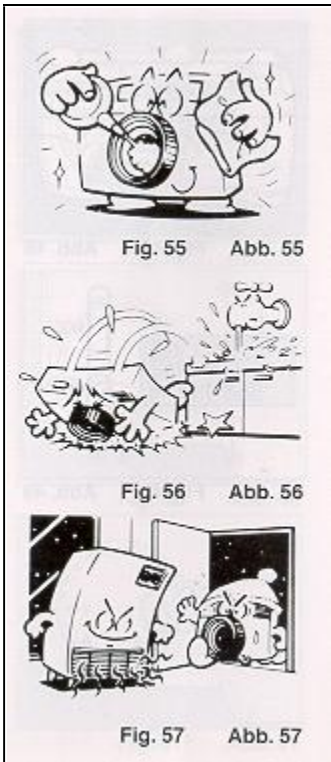

* If there is dirt on the lens or Distance Measuring Windows and in the camera body, do not attempt to remove it with your fingers. Use a blower to blow the dust away, or wipe the surface gently with camera lens tissue or a soft cloth. (Fig. 55)

* Camera malfunction can be caused by impact, humidity, salt etc. After using the camera at the beach or places where there is salt spray, high humidity or chemicals, wipe it off carefully. (Fig. 56)

* Take care not to expose the camera to sudden changes in temperature, as that may cause condensation on the lens and film or inside the body, or other malfunctions. (Fig. 57)

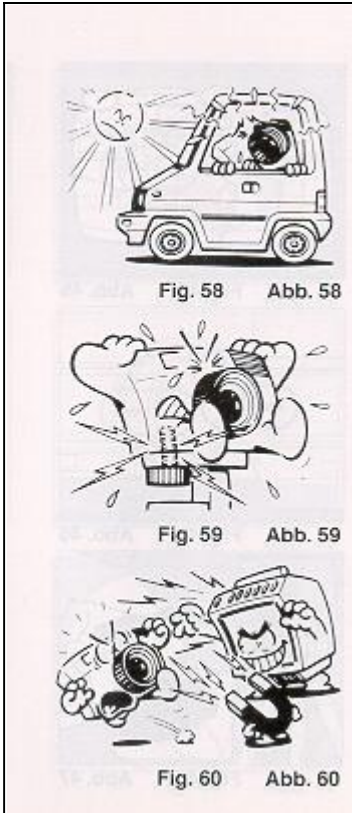

* Do not expose the camera for a long period of time to extremely high temperatures, such as in your car or on the beach, as this may ruin your film, or cause other malfunctions. (Fig. 58)

* When using a tripod, do not try to force a long screw into the socket. The screw length should be less than 5.7 mm (1/4 inch). (Fig. 59)

* Do not place the camera near equipment that has strong magnetic fields such as a television or radio

TROUBLESHOOTING

When the shutter does not release or the pictures appear blurry, check the table below. If the camera still does not function properly, take it to your nearest Ricoh Service Center.

1. When the shutter does not release

Cause	Check	Remedy	Page
The power is not on.	Is the lens in the storage position? _The power is not on.	Turn the Drive Dial to ON to turn the power on.	pg. 19
The batteries are exhausted.	Is the Battery Mark blinking in the LCD Panel?	Replace the batteries with new ones.	pg. 18
The flash is charging.	Is the Flash Monitor (red) next to the Viewfinder blinking?	Wait until the Flash Monitor turns off.	Pg. 25
The shooting distance is too short.	Is the AF Monitor (green) next to the Viewfinder blinking? Or, is the subject in the auto-focus marks nearer than 1 m (3.3 ft.) away?	Change the shooting distance. (Move more than 1 m away from the subject.)	Pg. 23
The film is not loaded correctly.	Is "0" blinking in the Exposure Counter?	Open the Back Cover and reload the film.	pg. 19
The film is rewound.	Is "E" displayed on the Exposure Counter?	Replace the film with a new one.	pg. 19

2. When the pictures appear blurry

Cause	Remedy	Page
The subject is not in the auto-focus area.	Make sure the subject to be focused is within the multi-focus marks, or use the S. AF Mode. The multi auto-focus area is larger in telephoto than in wide.	pg. 23
The camera focused on something in front of the main subject.	Make sure there is no other object in front of the main subject in the AF marks.	pg. 23
The Shutter Release Button was pressed when the AF Monitor was blinking to indicate a subject that was difficult to focus.	Press the Shutter Release Button halfway and make sure the AF Monitor is lit before pressing it completely.	pg. 24

MAJOR SPECIFICATIONS

Type: Fully automatic 35 mm autofocus lens shutter camera with built-in zoom lens

Lens: 38 mm f/4.5-130 mm f/9.5 zoom lens, 6 elements, 3 groups

Focusing: Multi-autofocus type with single AF facility
Passive type with auxiliary AF light in dark conditions
Multi-autofocus in 7 zones
Min. focus distance: 1.0 m (3.3 ft.) - infinity

Shutter: Programmed electronic shutter: 2-1/330 sec.

Viewfinder: Real image zoom viewfinder

Exposure Adjustment: Dual SPD photocell, Programmed zoom AE with automatic backlight control
Coupling range EV3.5 - 17 (Wide, ISO 100), EV5.8 - 19.3 (Tele) (ISO 100)

Film Speed: ISO 50-3200, Compatible with DX code system, Non-DX films are set to ISO 100

Film Load/Wind/Rewinding: Ricoh auto-load system pre-wind system. Film pre-winds to the last frame number
when back cover closed. Mid-roll rewind possible

Exposure Counter: Electronic, Counts down number of exposures left

Built-in Flash: Electronic Flash automatically activates in dim light and backlight.
Modes: Auto, Red eye reduction, On. Off, Slow synchro, Red eye reduction slow synchro

Flash Range: Guide number; 17-21 (ISO 100/m)
56-69 (ISO 100/ft.)
(ISO 100) Wide: 1 m-5.3 m (3.3 ft. - 17.5 ft.),
Tele: 1 m-3.2 m (3.3 ft. - 10.5 ft.)
(ISO 400) Wide: 1 m-10.6 m (3.3 ft. - 35 ft.)
Tele: 1 m-6.4 m (3.3 ft. - 21 ft.)

Flash Recycle time: Approx. 4 sec.

Other Features: Twin dial selector with/LED, Zoom flash, Super night mode, Action mode, Port mode, Inf. mode, Single AF mode. Continuous Shooting mode.
Remote control possible with optional remote controller RC-3/RC-3N
Date imprinting (date version)

Power Source: 3V lithium battery x 2 CR123A or equivalent

Dimensions: 128 mm (W) X 72 mm (H) x 52 mm (D),
5in.(W) X 2.8in.(H) X 2 in.(D)

Weight: 295 g/10.4 oz. (without battery) Specifications subject to change without notice